

# CATERPILLAR®

## Declaração de conformidade da Comunidade Económica Europeia respeitante a tipos de equipamento aprovados e verificados ou auto-certificados

O abaixo-assinado, Robert Briggs, certifica que o equipamento de construção especificado aqui especificado:

- 1. Categoria Carregadeira de Rodas
- 2. Marca CATERPILLAR
- 3. Tipo 216
- 4. Número de série do tipo de equipamento 4NZ01825
- 5. Ano de fabricação 2001

foi fabricado em conformidade com

- Exame CEE de tipo (1)
- Auto-certificados CEE (2)

como indicado na tabela abaixo

No caso de exame CEE de tipo ou auto-certificados CEE:

| Separados  | No.           | Data       | Organiz. Autorizado         |
|------------|---------------|------------|-----------------------------|
| 86/662/EEC | GB/02/1147/99 | 1999-10-25 | AVT Ltd.-England (95/27/EC) |
| 98/37/EC   | 216SAN912     | 1999-12-03 | ..... N/A ..... (2)         |
| 89/336/EEC | 216SAN912     | 1999-12-03 | ..... N/A ..... (2)         |

6. Provisões especiais.... Potencia neta instalada 37 kW(3) a 2600 R.P.M.

(3) Potencia neta definida e determinada de acordo com Anexo I do Directivo 80/1269/CEE de Dezembro 16 de 1980.

Emitido em  
SANFORD BCP  
5000 WOMACK ROAD  
SANFORD NC 27330-9594

Data  
2001-10-24

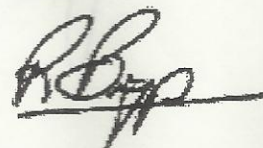
Firma  

Robert Briggs  
Administrative



# Operation and Maintenance Manual

---

## **216B3, 226B3, 236B3, 242B3, 252B3 Skid Steer Loaders and , 247B3, 257B3 Multi Terrain Loaders and , 259B3 Compact Track Loader**

---

JXM 1-UP (216B3)  
DSN 1-UP (216B3)  
PWK 1-UP (216B3)  
CD3 1-UP (216B3)  
HR2 1-UP (216B3)  
MWD 1-UP (226B3)  
SNA 1-UP (226B3)  
DXZ 1-UP (226B3)  
AS2 1-UP (226B3)  
A9H 1-UP (236B3)  
SRS 1-UP (242B3)  
TSL 1-UP (247B3)  
ESL 1-UP (247B3)  
KB3 1-UP (247B3)  
TNK 1-UP (252B3)  
B7H 1-UP (257B3)  
YYZ 1-UP (259B3)

Language: Original Instructions

## Important Safety Information

Most accidents that involve product operation, maintenance and repair are caused by failure to observe basic safety rules or precautions. An accident can often be avoided by recognizing potentially hazardous situations before an accident occurs. A person must be alert to potential hazards, including human factors that can affect safety. This person should also have the necessary training, skills and tools to perform these functions properly.

**Improper operation, lubrication, maintenance or repair of this product can be dangerous and could result in injury or death.**

**Do not operate or perform any lubrication, maintenance or repair on this product, until you verify that you are authorized to perform this work, and have read and understood the operation, lubrication, maintenance and repair information.**

Safety precautions and warnings are provided in this manual and on the product. If these hazard warnings are not heeded, bodily injury or death could occur to you or to other persons.

The hazards are identified by the "Safety Alert Symbol" and followed by a "Signal Word" such as "DANGER", "WARNING" or "CAUTION". The Safety Alert "WARNING" label is shown below.



The meaning of this safety alert symbol is as follows:

**Attention! Become Alert! Your Safety is Involved.**

The message that appears under the warning explains the hazard and can be either written or pictorially presented.

A non-exhaustive list of operations that may cause product damage are identified by "NOTICE" labels on the product and in this publication.

**Caterpillar cannot anticipate every possible circumstance that might involve a potential hazard. The warnings in this publication and on the product are, therefore, not all inclusive. You must not use this product in any manner different from that considered by this manual without first satisfying yourself that you have considered all safety rules and precautions applicable to the operation of the product in the location of use, including site-specific rules and precautions applicable to the worksite. If a tool, procedure, work method or operating technique that is not specifically recommended by Caterpillar is used, you must satisfy yourself that it is safe for you and for others. You should also ensure that you are authorized to perform this work, and that the product will not be damaged or become unsafe by the operation, lubrication, maintenance or repair procedures that you intend to use.**

The information, specifications, and illustrations in this publication are on the basis of information that was available at the time that the publication was written. The specifications, torques, pressures, measurements, adjustments, illustrations, and other items can change at any time. These changes can affect the service that is given to the product. Obtain the complete and most current information before you start any job. Cat dealers have the most current information available.



**When replacement parts are required for this product Caterpillar recommends using Cat replacement parts.**

**Failure to follow this warning may lead to premature failures, product damage, personal injury or death.**

**In the United States, the maintenance, replacement, or repair of the emission control devices and systems may be performed by any repair establishment or individual of the owner's choosing.**

## Table of Contents

|                |   |
|----------------|---|
| Foreword ..... | 4 |
|----------------|---|

### Safety Section

|  |    |
|--|----|
| Safety Messages (Work Tools) .....             | 6  |
| Safety Messages .....                          | 14 |
| Additional Messages .....                      | 22 |
| General Hazard Information .....               | 24 |
| Crushing Prevention and Cutting Prevention ..  | 27 |
| Burn Prevention .....                          | 27 |
| Fire Prevention and Explosion Prevention ..... | 28 |
| Fire Safety .....                              | 31 |
| Fire Extinguisher Location .....               | 32 |
| Electrical Storm Injury Prevention .....       | 32 |
| Before Starting Engine .....                   | 32 |
| Restricted Visibility .....                    | 32 |
| Visibility Information .....                   | 33 |
| Engine Starting .....                          | 33 |
| Before Operation .....                         | 34 |
| Operation .....                                | 34 |
| Work Tools .....                               | 36 |
| Demolition .....                               | 36 |
| Parking .....                                  | 37 |
| Slope Operation .....                          | 37 |
| Equipment Lowering with Engine Stopped .....   | 38 |
| Sound Information and Vibration Information .  | 38 |
| Guards (Operator Protection) .....             | 41 |

### Product Information Section

|                                  |    |
|----------------------------------|----|
| General Information .....        | 43 |
| Identification Information ..... | 60 |

### Operation Section

|   |     |
|---|-----|
| Before Operation .....                    | 73  |
| Machine Operation .....                   | 75  |
| Engine Starting .....                     | 97  |
| Operation .....                           | 98  |
| Parking .....                             | 113 |
| Transportation Information .....          | 117 |
| Towing Information .....                  | 130 |
| Engine Starting (Alternate Methods) ..... | 131 |

### Maintenance Section

|   |     |
|---|-----|
| Maintenance Access .....                        | 133 |
| Lubricant Viscosities and Refill Capacities ... | 140 |
| Maintenance Support .....                       | 147 |
| Maintenance Interval Schedule .....             | 154 |

### Reference Information Section

|                           |     |
|---------------------------|-----|
| Reference Materials ..... | 222 |
|---------------------------|-----|

### Index Section

|             |     |
|-------------|-----|
| Index ..... | 231 |
|-------------|-----|

## Foreword

### California Proposition 65 Warning

**Diesel engine exhaust and some of its constituents are known to the State of California to cause cancer, birth defects, and other reproductive harm.**



**WARNING – This product can expose you to chemicals including ethylene glycol, which is known to the State of California to cause birth defects or other reproductive harm. For more information go to:**

**[www.P65Warnings.ca.gov](http://www.P65Warnings.ca.gov)**

**Do not ingest this chemical. Wash hands after handling to avoid incidental ingestion.**



**WARNING – This product can expose you to chemicals including lead and lead compounds, which are known to the State of California to cause cancer, birth defects, or other reproductive harm. For more information go to:**

**[www.P65Warnings.ca.gov](http://www.P65Warnings.ca.gov)**

**Wash hands after handling components that may contain lead.**

### Literature Information

This manual should be stored in the operator's compartment in the literature holder or seat back literature storage area.

This manual contains safety information, operation instructions, transportation information, lubrication information, and maintenance information.

Some photographs or illustrations in this publication show details or attachments that can be different from your machine. Guards and covers might have been removed for illustrative purposes.

Continuing improvement and advancement of product design might have caused changes to your machine which are not included in this publication. Read, study, and keep this manual with the machine.

Whenever a question arises regarding your machine, or this publication, please consult your Cat dealer for the latest available information.

### Safety

The safety section lists basic safety precautions. In addition, this section identifies the text and locations of warning signs and labels used on the machine.

Read and understand the basic precautions listed in the safety section before operating or performing lubrication, maintenance, and repair on this machine.

### Operation

The operation section is a reference for the new operator and a refresher for the experienced operator. This section includes a discussion of gauges, switches, machine controls, attachment controls, transportation, and towing information.

Photographs and illustrations guide the operator through correct procedures of checking, starting, operating, and stopping the machine.

Operating techniques outlined in this publication are basic. Skill and techniques develop as the operator gains knowledge of the machine and its capabilities.

### Maintenance

The maintenance section is a guide to equipment care. The Maintenance Interval Schedule (MIS) lists the items to be maintained at a specific service interval. Items without specific intervals are listed under the "When Required" service interval. The Maintenance Interval Schedule lists the page number for the step-by-step instructions required to accomplish the scheduled maintenance. Use the Maintenance Interval Schedule as an index or "one safe source" for all maintenance procedures.

### Maintenance Intervals

Use the service hour meter to determine servicing intervals. Calendar intervals shown (daily, weekly, monthly, etc.) can be used instead of service hour meter intervals if the calendar intervals provide more convenient servicing schedules and approximate the indicated service hour meter reading. Perform the recommended service at the interval that occurs first.

Under severe, dusty, or wet operating conditions, more frequent lubrication than is specified in the maintenance intervals chart might be necessary.

Perform service on items at multiples of the original requirement. For example, at every 500 service hours or 3 months, also service those items listed under every 250 service hours or monthly and every 10 service hours or daily.

## Certified Engine Maintenance

Proper maintenance and repair are essential to keep the engine and machine systems operating correctly. As the heavy-duty off-road diesel engine owner, you are responsible for the performance of the required maintenance listed in the Owner Manual, Operation and Maintenance Manual, and Service Manual.

It is prohibited for any person engaged in the business of repairing, servicing, selling, leasing, or trading engines or machines to remove, alter, or to render inoperative, any emission-related device or element of design installed on or in an engine or machine that is in compliance with all applicable regulations of the intended country to which it has been shipped. Certain elements of the machine and engine such as the exhaust system, fuel system, electrical system, intake air system, and cooling system may be emission-related and should not be altered unless approved by Caterpillar.

## Machine Capacity

Additional attachments or modifications may exceed machine design capacity which can adversely affect performance characteristics. Included would be stability and system certifications such as brakes, steering, and rollover protective structures (ROPS). Contact your Cat dealer for further information.

## Product Identification Number

Effective First Quarter 2001 the Product Identification Number (PIN) has changed from 8 to 17 characters. To provide uniform equipment identification, construction equipment manufacturers are moving to comply with the latest version of the product identification numbering standard. Non-road machine PINs are defined by ISO 10261. The new PIN format will apply to all machines and generator sets. The PIN plates and frame marking will display the 17 character PIN. The new format will look like the following:

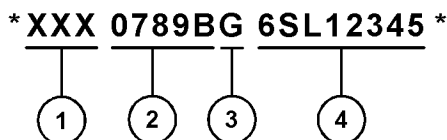

Illustration 1

g03891925

Where:

1. World Manufacturing Code (characters 1-3)

2. Machine Descriptor (characters 4-8)

3. Check Character (character 9)

4. Machine Indicator Section (MIS) or Product Sequence Number (characters 10-17). These were previously referred to as the Serial Number.

Machines and generator sets produced before First Quarter 2001 will maintain their 8 character PIN format.

Components such as engines, transmissions, axles, and work tools will continue to use an 8 character Serial Number (S/N).

## Safety Section

i02811655

### Safety Messages (Work Tools)

**SMCS Code:** 7000; 7405

There are several specific safety messages on these work tools. The exact location of the hazards and the description of the hazards are reviewed in this section. Please become familiarized with all safety messages.

Make sure that all of the safety messages are legible. Clean the safety messages or replace the safety messages if you cannot read the words. Replace the illustrations if the illustrations are not legible. When you clean the safety messages, use a cloth, water and soap. Do not use solvent, gasoline, or other harsh chemicals to clean the safety messages. Solvents, gasoline, or harsh chemicals could loosen the adhesive that secures the safety message. Loose adhesive will allow the safety message to fall.

Replace any safety message that is damaged, or missing. If a safety message is attached to a part that is replaced, install a safety message on the replacement part. Any Caterpillar dealer can provide new safety messages.

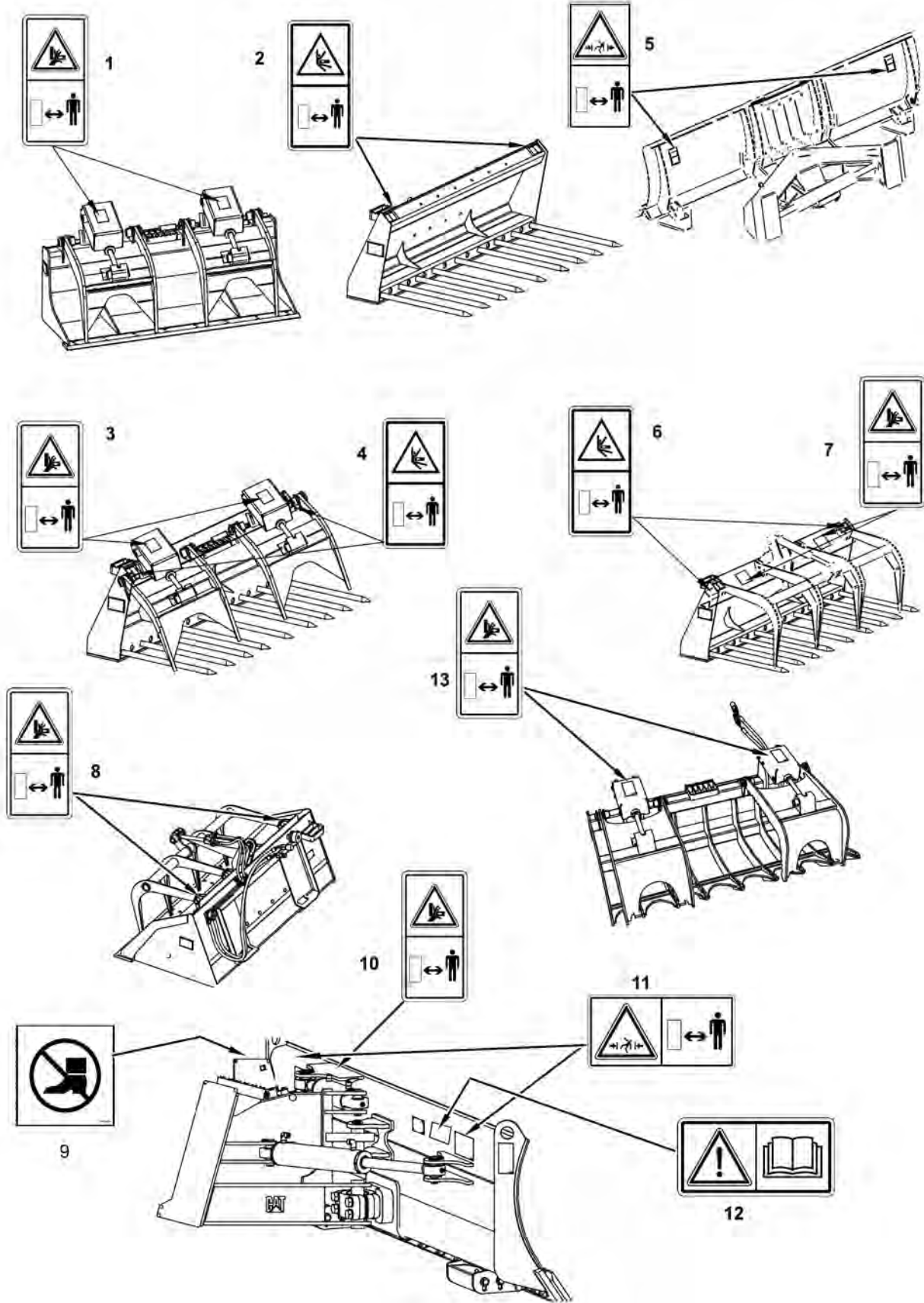

Illustration 2

g01402473

### Industrial Grapple Bucket (1)

These warning messages are located on top of the guards for the grapple cylinders.



Illustration 3

g01378775



**No clearance for person in this area during operation. Severe injury or death from crushing could occur. Stay away from the work tool while it is in operation.**

### Utility Fork (2)

These warning messages are located on top of the fork carriage.



Illustration 4

g01389170



**No clearance for person in this area during operation. Severe injury or death from impalement could occur. Stay away from the work tool while it is in operation.**

### Industrial Grapple Fork (3)

These warning messages are located on the guards for the grapple cylinders.



Illustration 5

g01378775

**⚠ WARNING**

No clearance for person in this area during operation. Severe injury or death from crushing could occur. Stay away from the work tool while it is in operation.

### Industrial Grapple Fork (4)

These warning messages are located on top of the fork carriage.



Illustration 6

g01389170

**⚠ WARNING**

No clearance for person in this area during operation. Severe injury or death from impalement could occur. Stay away from the work tool while it is in operation.

### Angle Blade (5)

These warning messages are located on the back side of the blade.



Illustration 7

g01377717

**⚠ WARNING**

No clearance for person in this area during operation. Severe injury or death from crushing could occur. Stay away from the work tool while it is in operation.

### Utility Grapple Fork (6)

These warning messages are located on top of the fork carriage.



Illustration 8

g01389170

**⚠ WARNING**

No clearance for person in this area during operation. Severe injury or death from impalement could occur. Stay away from the work tool while it is in operation.

### Utility Grapple Fork (7)

These warning messages are located on top of the grapple frame.



Illustration 9

g01378775

**⚠ WARNING**  
 No clearance for person in this area during operation. Severe injury or death from crushing could occur. Stay away from the work tool while it is in operation.

### Utility Grapple Bucket (8)

These warning messages are located on top of the grapple frame.



Illustration 10

g01378775

**⚠ WARNING**  
 No clearance for person in this area during operation. Severe injury or death from crushing could occur. Stay away from the work tool while it is in operation.

### Dozer Blade (9)

This warning message is located on top of the dozer blade.



Illustration 11

g00946617

**⚠ WARNING**

**Falling Hazard - Area may be oily and slippery. Do not step on cylinders. Serious injury or death could occur from a fall.**

### Dozer Blade (10)

This warning message is located on top of the dozer blade.



Illustration 12

g01378775

**⚠ WARNING**

**No clearance for person in this area during operation. Severe injury or death from crushing could occur. Stay away from the work tool while it is in operation.**

### Dozer Blade (11)

These warning messages are located on the back side of the blade.

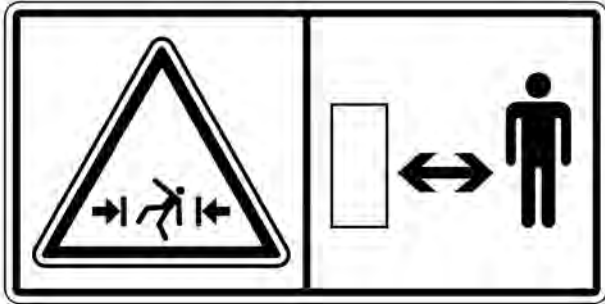

Illustration 13

g01371644

**⚠ WARNING**

No clearance for person in this area during operation. Severe injury or death from crushing could occur. Stay away from the work tool while it is in operation.

## Dozer Blade (12)

This warning is located on right hand side on the back of the blade.

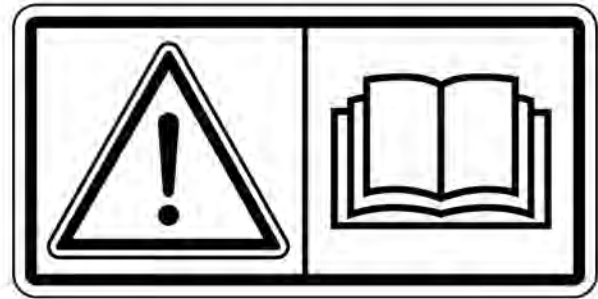

Illustration 14

g01370904

**⚠ WARNING**

DO NOT OPERATE OR WORK ON THIS MACHINE UNLESS YOU HAVE READ AND UNDERSTAND THE INSTRUCTIONS AND WARNINGS IN THE OPERATION AND MAINTENANCE MANUALS. FAILURE TO FOLLOW THE INSTRUCTIONS OR HEED THE WARNINGS COULD RESULT IN INJURY OR DEATH. CONTACT ANY CATERPILLAR DEALER FOR REPLACEMENT MANUALS. PROPER CARE IS YOUR RESPONSIBILITY.

## Grapple Rake (13)

These warning messages are located on top of the grapple frame.



Illustration 15

g01378775

**⚠ WARNING**

No clearance for person in this area during operation. Severe injury or death from crushing could occur. Stay away from the work tool while it is in operation.

---

i03878962

## Safety Messages

SMCS Code: 7000; 7405

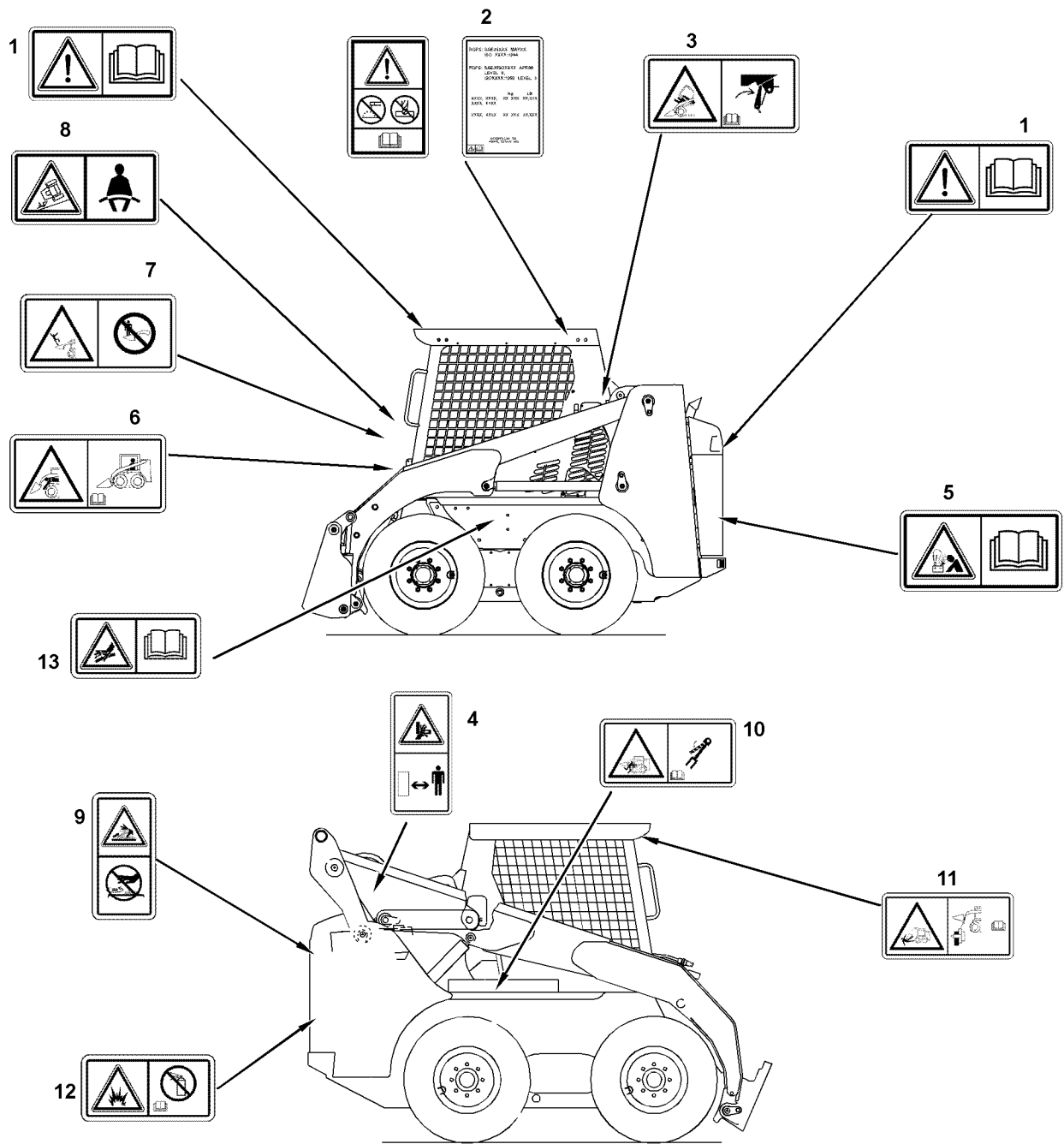

Illustration 16

Safety Section  
Safety Messages

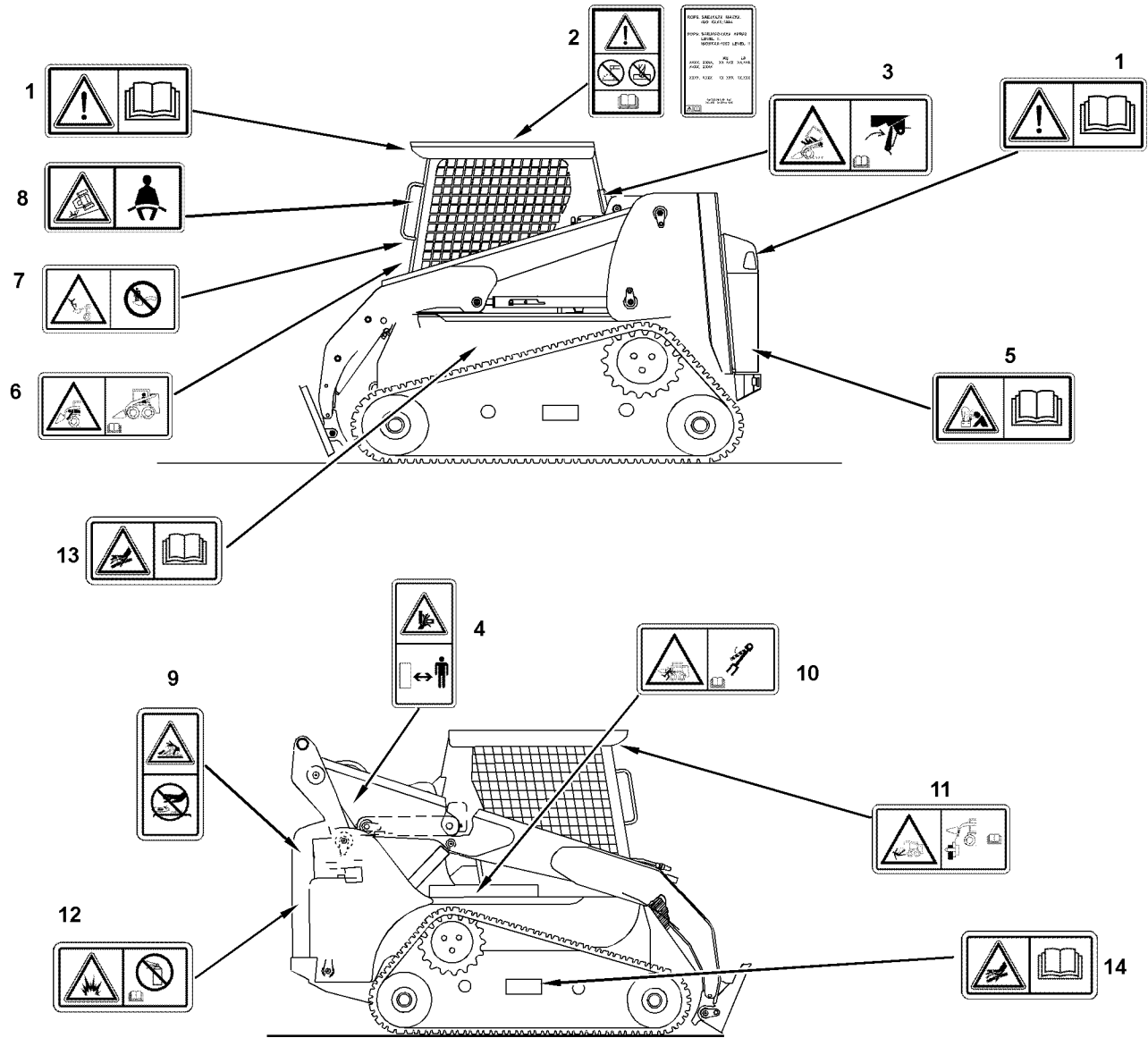

Illustration 17

g02125630

There are several specific safety messages on this machine. The exact location of the hazards and the description of the hazards are reviewed in this section. Please become familiarized with all safety messages.

Make sure that all of the safety messages are legible. Clean the safety messages or replace the safety messages if you cannot read the words. Replace the illustrations if the illustrations are not legible. When you clean the safety messages, use a cloth, water and soap. Do not use solvent, gasoline, or other harsh chemicals to clean the safety messages. Solvents, gasoline, or harsh chemicals could loosen the adhesive that secures the safety message. Loose adhesive will allow the safety message to fall.

Replace any safety message that is damaged, or missing. If a safety message is attached to a part that is replaced, install a safety message on the replacement part. Any Caterpillar dealer can provide new safety messages.

## Do Not Operate (1)

This warning message is located inside the cab on the upper left side. This warning message is located also on the engine.



Illustration 18

g01370904

### **WARNING**

**Read and understand the instructions and warnings in the operation and maintenance manuals. Contact any Caterpillar dealer for replacement manuals. Proper care is your responsibility.**

**Be alert! Know work conditions. Note and avoid all hazards and obstructions. Keep by-standers away when operating.**

**Fasten seat belt and lower armrest.**

**Make certain all controls are in neutral position and start engine.**

**Disengage parking brake.**

**Machine controls are active.**

**Failure to follow the instructions or heed the warnings could result injury or death.**

## Rollover Protective Structure/ Falling Object Protective Structure (2)

This warning film and the certification film are located inside the cab on the upper left side.



Illustration 19

g01211895

### **WARNING**

**Structural damage, an overturn, modification, alteration, or improper repair can impair this structure's protection capability thereby voiding this certification. Do not weld on or drill holes in the structure. Consult a Caterpillar dealer to determine this structure's limitations without voiding its certification.**

This machine has been certified to the standards that are listed on the certification plate. The maximum mass of the machine, which includes the operator and the attachments without a payload, should not exceed the mass on the certification film.

## Cab Support (3)

This warning message is located on the left side of the machine near the cab support lever. This warning message is also located inside the cab on the lower left side.

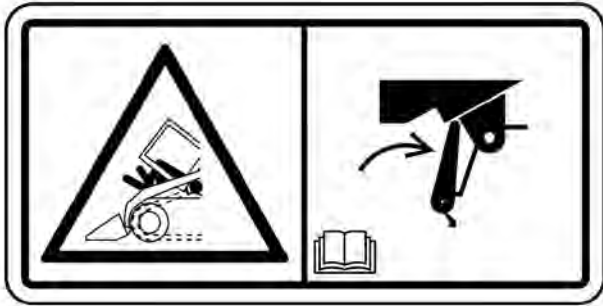

Illustration 20

g01427440

**⚠ WARNING**

Do not go beneath cab unless cab is empty and support lever is engaged.

Failure to follow the instructions or heed the warnings could result in injury or death.

### Crush Hazard (4)

This warning is located on both of the loader arms of the machines that are equipped with extended reach.



Illustration 21

g01378775

**⚠ WARNING**

No clearance for person in this area during operation. Severe injury or death from crushing could occur. Stay away from the work tool while it is in operation.

### Batteries (5)

This warning message is located on the inside of the engine access door.

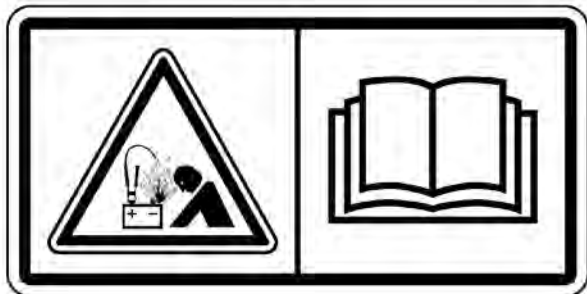

Illustration 22

g01370909

**⚠ WARNING**

Improper jumper cable connections can cause explosion resulting in personal injury. Batteries may be located in separate compartments, always connect positive (+) cable to positive (+) terminal of battery connected to starter solenoid and negative (-) cable from external source to engine block or frame.

### Stay Inside Operator Station (6)

This warning message is located below the operator seat.

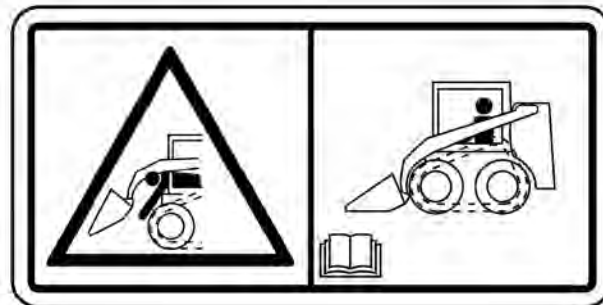

Illustration 23

g01427449

**⚠ WARNING**

Keep your body inside the operator station while operating the loader.

Never work with your arms, feet or legs beyond the operator station.

Failure to follow the instructions or heed the warnings will result in injury or death.

### Never Permit Riders (7)

This warning message is located below the operator seat.



Illustration 24

g01427444

**⚠ WARNING**

Never permit riders.

Never use work tool for a work platform.

Failure to follow the instructions or heed the warnings could result in injury or death.

### Seat Belt (8)

This warning message is located below the operator seat.



Illustration 25

g01370908

**⚠ WARNING**

A seat belt should be worn at all times during machine operation to prevent serious injury or death in the event of an accident or machine overturn. Failure to wear a seat belt during machine operation may result in serious injury or death.

Refer to Operation and Maintenance Manual, "Seat Belt" for more information.

### Pressurized System (9)

This warning message is located below the radiator cap.



Illustration 26

g01378799

**⚠ WARNING**

Pressurized system: Hot coolant can cause serious burn. To open cap, stop engine, wait until radiator is cool. Then loosen cap slowly to relieve the pressure.

### Brace for the Loader Lift Arms (10)

This warning message is located on the brace for the loader lift arms.

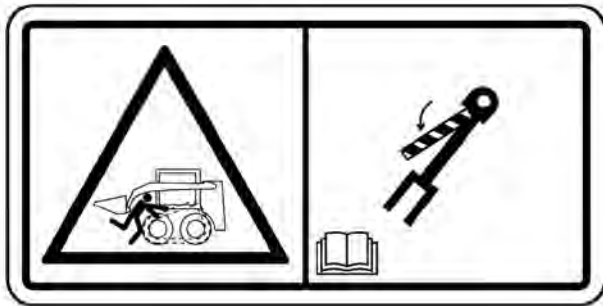

Illustration 27

g01427443

### **WARNING**

Loader lift arm brace must be in place when working under raised lift arms.

Failure to follow the instructions or heed the warnings could result in injury or death.

Refer to Operation and Maintenance Manual, "Loader Lift Arm Brace Operation" for operating information.

### **Work Tool Coupler (11)**

This warning message is located inside the cab on the upper left side.

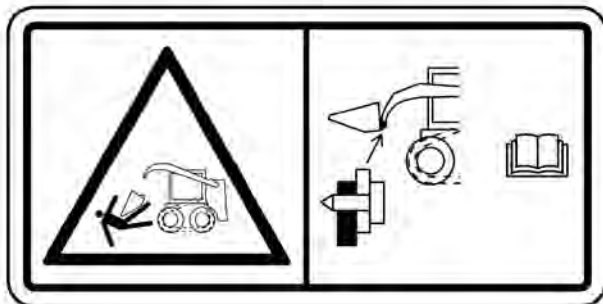

Illustration 28

g01427447

### **WARNING**

Improper Attachment of the Work Tool could result in injury or death.

Do not operate the machine without confirmation that the coupler pins are fully engaged. Follow the operating procedures in the Operation and Maintenance Manual.

Tilt the work tool downward.

Put down pressure on the work tool.

Move the machine backward. Ensure that the work tool has not separated from the coupler assembly.

### **Aerosol Starting Aid (12)**

This warning message is located on the air cleaner housing.



Illustration 29

g01372254

### **WARNING**

Do not use aerosol types of starting aids such as ether. Such use could result in an explosion and personal injury.

### **Accumulator (13)**

This warning message is located near the accumulator underneath the cab.

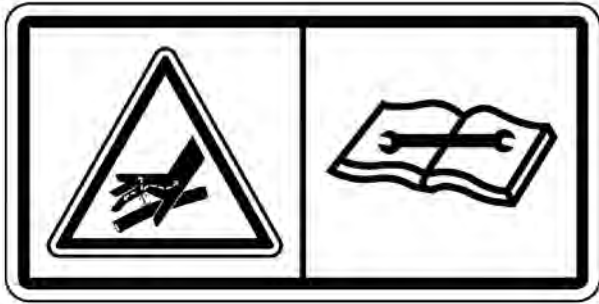

Illustration 30

g01372252

**⚠ WARNING**

Accumulator may contain high pressure oil. Do not service the accumulator or any hydraulic lines until all of the pressure has been relieved. See the Service Manual for proper procedures. Failure to heed this warning could result in injury or death.

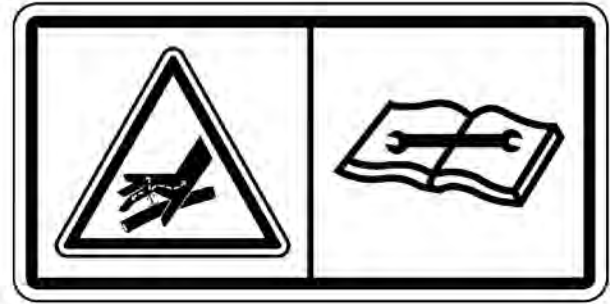

Illustration 31

g01372252

**⚠ WARNING**

Accumulator may contain high pressure oil. Do not service the accumulator or any hydraulic lines until all of the pressure has been relieved. See the Service Manual for proper procedures. Failure to heed this warning could result in injury or death.

## Accumulator (14)

i06616802

This warning message is located on both sides of the machine near the access panel for the track tension cylinder. This warning message is only located on CTL machines.

## Additional Messages

**SMCS Code:** 7000; 7405

There are several specific messages on this machine. Become familiarized with all messages.

Make sure that all the messages are legible. Clean the messages or replace the messages if you cannot read the words.

When you clean the messages, use a cloth, water, and soap. Do not use solvent, gasoline, or other harsh chemicals to clean the messages. Solvents, gasoline, or harsh chemicals could loosen the adhesive that secures the messages. Loose adhesive will allow the messages to fall.

Replace the illustrations if the illustrations are not legible. Replace any message that is damaged, or missing. If a message is attached to a part that is replaced, install a message on the replacement part.

Consult your Caterpillar dealer for replacement of messages.



Illustration 32 g06008894  
 Equipped only for serial number prefixes PWK and DXZ.

### Work Tool Detach (1)

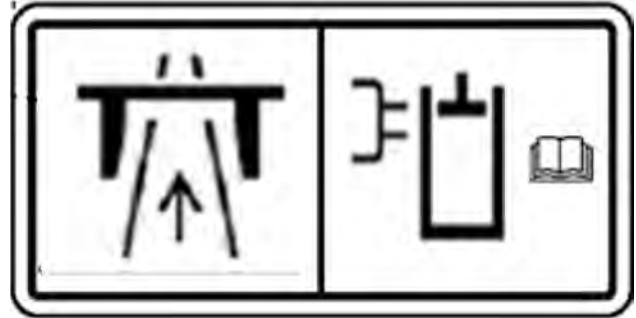

Illustration 33 g06008892

Ensure that the machine has a work tool that is approved for driving on the road when attached. If not, detach work tool from the machine before driving on the road.

### Lift Arm Down (2)



Illustration 34 g06008886

Before driving the machine on the road, the lift arm must be in the lowermost possible position. Lowering the lift arm will help to get the correct position and orientation of head lamps.

## Product Link (If Equipped)



Illustration 35

g01418953

If your machine is equipped with the Product Link System, this film will be located in the cab. The Product Link System is a satellite communication device that transmits information regarding the machine back to Caterpillar and Caterpillar dealers and customers. All logged events and diagnostic codes that are available to the Caterpillar Electronic Technician (ET) on the CAT data link can be sent to the satellite. Information can also be sent to the Product Link System. The information is used to improve Caterpillar products and Caterpillar services.

Refer to Operation and Maintenance Manual, "Product Link" for more information.

i07746355

## General Hazard Information

SMCS Code: 7000

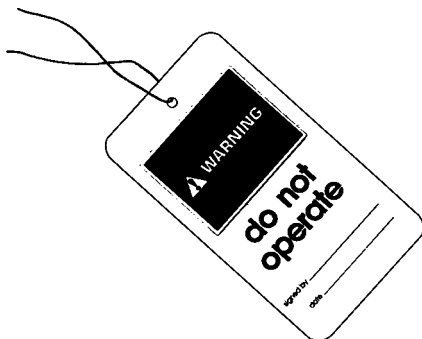

Illustration 36

g00104545

Typical example

Attach a "Do Not Operate" warning tag or a similar warning tag to the start switch or to the controls. Attach the warning tag before you service the equipment or before you repair the equipment. Warning tag SEHS7332 is available from your Cat dealer.

### **WARNING**

**Operating the machine while distracted can result in the loss of machine control. Use extreme caution when using any device while operating the machine. Operating the machine while distracted can result in personal injury or death.**

Know the width of your equipment to maintain proper clearance when you operate the equipment near fences or near boundary obstacles.

Be aware of high-voltage power lines and power cables that are buried. If the machine comes in contact with these hazards, serious injury or death may occur from electrocution.

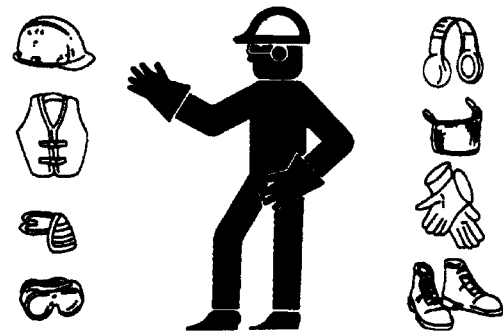

Illustration 37

g00702020

Wear a hard hat, protective glasses, and other protective equipment, as required.

Do not wear loose clothing or jewelry that can snag on controls or on other parts of the equipment.

Make sure that all protective guards and all covers are secured in place on the equipment.

Keep the equipment free from foreign material. Remove debris, oil, tools, and other items from the deck, from walkways, and from steps.

Secure all loose items such as lunch boxes, tools, and other items that are not a part of the equipment.

Know the appropriate work site hand signals and the personnel that are authorized to give the hand signals. Accept hand signals from one person only.

Do not smoke when you service an air conditioner. Also, do not smoke if refrigerant gas may be present. Inhaling the fumes that are released from a flame that contacts air conditioner refrigerant can cause bodily harm or death. Inhaling gas from air conditioner refrigerant through a lighted cigarette can cause bodily harm or death.

Never put maintenance fluids into glass containers. Drain all liquids into a suitable container.

Obey all local regulations for the disposal of liquids.

Use all cleaning solutions with care. Report all necessary repairs.

Do not allow unauthorized personnel on the equipment.

Unless you are instructed otherwise, perform maintenance with the equipment in the servicing position. Refer to Operation and Maintenance Manual for the procedure for placing the equipment in the servicing position.

When you perform maintenance above ground level, use appropriate devices such as ladders or man lift machines. If equipped, use the machine anchorage points and use approved fall arrest harnesses and lanyards.

## **Pressurized Air and Water**

Pressurized air and/or water can cause debris and/or hot water to be blown out. The debris and/or hot water could result in personal injury.

When pressurized air and/or pressurized water is used for cleaning, wear protective clothing, protective shoes, and eye protection. Eye protection includes goggles or a protective face shield.

The maximum air pressure for cleaning purposes must be reduced to 205 kPa (30 psi) when the nozzle is deadheaded and the nozzle is used with an effective chip deflector and personal protective equipment. The maximum water pressure for cleaning purposes must be below 275 kPa (40 psi).

Avoid direct spraying of water on electrical connectors, connections, and components. When using air for cleaning, allow the machine to cool to reduce the possibility of fine debris igniting when re-deposited on hot surfaces.

## **Trapped Pressure**

Pressure can be trapped in a hydraulic system. Releasing trapped pressure can cause sudden machine movement or attachment movement. Use caution if you disconnect hydraulic lines or fittings. High-pressure oil that is released can cause a hose to whip. High-pressure oil that is released can cause oil to spray. Fluid penetration can cause serious injury and possible death.

## **Fluid Penetration**

Pressure can be trapped in the hydraulic circuit long after the machine has been stopped. The pressure can cause hydraulic fluid or items such as pipe plugs to escape rapidly if the pressure is not relieved correctly.

Do not remove any hydraulic components or parts until pressure has been relieved or personal injury may occur. Do not disassemble any hydraulic components or parts until pressure has been relieved or personal injury may occur. Refer to the Service Manual for any procedures that are required to relieve the hydraulic pressure.

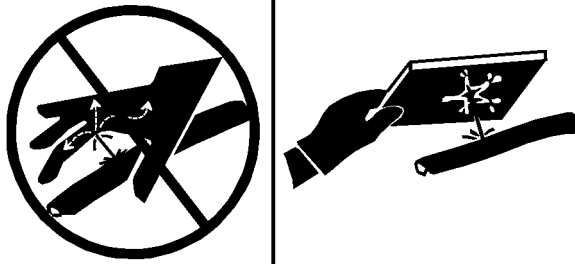

Illustration 38

g00687600

Always use a board or cardboard when you check for a leak. Leaking fluid that is under pressure can penetrate body tissue. Fluid penetration can cause serious injury and possible death. A pin hole leak can cause severe injury. If fluid is injected into your skin, you must get treatment immediately. Seek treatment from a doctor that is familiar with this type of injury.

## Containing Fluid Spillage

Care must be taken in order to ensure that fluids are contained during performance of inspection, maintenance, testing, adjusting, and repair of the equipment. Prepare to collect the fluid with suitable containers before opening any compartment or disassembling any component that contains fluids.

Refer to Special Publication, NENG2500, "Cat dealer Service Tool Catalog" for the following items:

- Tools that are suitable for collecting fluids and equipment that is suitable for collecting fluids
- Tools that are suitable for containing fluids and equipment that is suitable for containing fluids

Obey all local regulations for the disposal of liquids.

## Inhalation

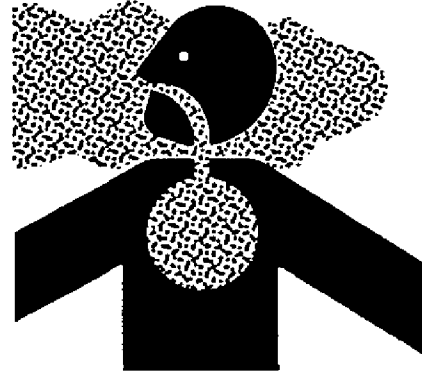

Illustration 39

g02159053

## Exhaust

Use caution. Exhaust fumes can be hazardous to your health. If you operate the machine in an enclosed area, adequate ventilation is necessary.

## Asbestos Information

Cat equipment and replacement parts that are shipped from Caterpillar are asbestos free. Caterpillar recommends the use of only genuine Cat replacement parts. Use the following guidelines when you handle any replacement parts that contain asbestos or when you handle asbestos debris.

Use caution. Avoid inhaling dust that might be generated when you handle components that contain asbestos fibers. Inhaling this dust can be hazardous to your health. The components that may contain asbestos fibers are brake pads, brake bands, lining material, clutch plates, and some gaskets. The asbestos that is used in these components is bound in a resin or sealed in some way. Normal handling is not hazardous unless airborne dust that contains asbestos is generated.

If dust that may contain asbestos is present, there are several guidelines that should be followed:

- Never use compressed air for cleaning.
- Avoid brushing materials that contain asbestos.
- Avoid grinding materials that contain asbestos.
- Use a wet method in order to clean up asbestos materials.
- A vacuum cleaner that is equipped with a high efficiency particulate air filter (HEPA) can also be used.

- Use exhaust ventilation on permanent machining jobs.
- Wear an approved respirator if there is no other way to control the dust.
- Comply with applicable rules and regulations for the work place. In the United States, use Occupational Safety and Health Administration (OSHA) requirements. These OSHA requirements can be found in “29 CFR 1910.1001”. In Japan, use the requirements found in the “Ordinance on Prevention of Health Impairment due to Asbestos” in addition to the requirements of the Industrial Safety and Health Act.
- Obey environmental regulations for the disposal of asbestos.
- Stay away from areas that might have asbestos particles in the air.

## Dispose of Waste Properly

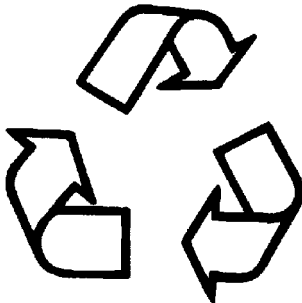

Illustration 40

g00706404

Improperly disposing of waste can threaten the environment. Potentially harmful fluids should be disposed of according to local regulations.

Always use leakproof containers when you drain fluids. Do not pour waste onto the ground, down a drain, or into any source of water.

i01359664

## Crushing Prevention and Cutting Prevention

**SMCS Code:** 7000

Support the equipment properly before you perform any work or maintenance beneath that equipment. Do not depend on the hydraulic cylinders to hold up the equipment. Equipment can fall if a control is moved, or if a hydraulic line breaks.

Do not work beneath the cab of the machine unless the cab is properly supported.

Unless you are instructed otherwise, never attempt adjustments while the machine is moving or while the engine is running.

Never jump across the starter solenoid terminals in order to start the engine. Unexpected machine movement could result.

Whenever there are equipment control linkages the clearance in the linkage area will change with the movement of the equipment or the machine. Stay clear of areas that may have a sudden change in clearance with machine movement or equipment movement.

Stay clear of all rotating and moving parts.

If it is necessary to remove guards in order to perform maintenance, always install the guards after the maintenance is performed.

Keep objects away from moving fan blades. The fan blade will throw objects or cut objects.

Do not use a kinked wire cable or a frayed wire cable. Wear gloves when you handle wire cable.

When you strike a retainer pin with force, the retainer pin can fly out. The loose retainer pin can injure personnel. Make sure that the area is clear of people when you strike a retainer pin. To avoid injury to your eyes, wear protective glasses when you strike a retainer pin.

Chips or other debris can fly off an object when you strike the object. Make sure that no one can be injured by flying debris before striking any object.

i07746334

## Burn Prevention

**SMCS Code:** 7000

Do not touch any part of an operating engine. Allow the engine to cool before any maintenance is performed on the engine. Relieve all pressure in the air system, in the oil system, in the lubrication system, in the fuel system, or in the cooling system before any lines, fittings, or related items are disconnected.

## Coolant

When the engine is at operating temperature, the engine coolant is hot. The coolant is also under pressure. The radiator and all lines to the heaters or to the engine contain hot coolant.

Any contact with hot coolant or with steam can cause severe burns. Allow cooling system components to cool before the cooling system is drained.

Check the coolant level only after the engine has been stopped.

Ensure that the filler cap is cool before removing the filler cap. The filler cap must be cool enough to touch with a bare hand. Remove the filler cap slowly to relieve pressure.

Cooling system conditioner contains alkali. Alkali can cause personal injury. Do not allow alkali to contact the skin, the eyes, or the mouth.

## Oils

Hot oil and hot components can cause personal injury. Do not allow hot oil to contact the skin. Also, do not allow hot components to contact the skin.

Remove the hydraulic tank filler cap only after the engine has been stopped. The filler cap must be cool enough to touch with a bare hand. Follow the standard procedure in this manual to remove the hydraulic tank filler cap.

## Batteries

The liquid in a battery is an electrolyte. Electrolyte is an acid that can cause personal injury. Do not allow electrolyte to contact the skin or the eyes.

Do not smoke while checking the battery electrolyte levels. Batteries give off flammable fumes which can explode.

Always wear protective glasses when you work with batteries. Wash hands after touching batteries. The use of gloves is recommended.

i07746336

## Fire Prevention and Explosion Prevention

SMCS Code: 7000

---



Illustration 41

g00704000

## General

All fuels, most lubricants, and some coolant mixtures are flammable.

To minimize the risk of fire or explosion, Caterpillar recommends the following actions.

Always perform a Walk-Around Inspection, which may help you identify a fire hazard. Do not operate a machine when a fire hazard exists. Contact your Cat dealer for service.

Understand the use of the primary exit and alternative exit on the machine. Refer to Operation and Maintenance Manual, "Alternative Exit".

Do not operate a machine with a fluid leak. Repair leaks and clean up fluids before resuming machine operation. Fluids that are leaking or spilled onto hot surfaces or onto electrical components can cause a fire. A fire may cause personal injury or death.

Remove flammable material such as leaves, twigs, papers, trash, and so on. These items may accumulate in the engine compartment or around other hot areas and hot parts on the machine.

Keep the access doors to major machine compartments closed and access doors in working condition in order to permit the use of fire suppression equipment, in case a fire should occur.

Clean all accumulations of flammable materials such as fuel, oil, and debris from the machine.

Do not operate the machine near any flame.

Keep shields in place. Exhaust shields (if equipped) protect hot exhaust components from oil spray or fuel spray in case of a break in a line, in a hose, or in a seal. Exhaust shields must be installed correctly.

Do not weld or flame cut on tanks or lines that contain flammable fluids or flammable material. Empty and purge the lines and tanks. Then clean the lines and tanks with a nonflammable solvent prior to welding or flame cutting. Ensure that the components are properly grounded in order to avoid unwanted arcs.

Dust that is generated from repairing nonmetallic hoods or fenders may be flammable and/or explosive. Repair such components in a well ventilated area away from open flames or sparks. Use suitable Personal Protection Equipment (PPE).

Inspect all lines and hoses for wear or deterioration. Replace damaged lines and hoses. The lines and the hoses should have adequate support and secure clamps. Tighten all connections to the recommended torque. Damage to the protective cover or insulation may provide fuel for fires.

Store fuels and lubricants in properly marked containers away from unauthorized personnel. Store oily rags and flammable materials in protective containers. Do not smoke in areas that are used for storing flammable materials.



Illustration 42

g03839130

Use caution when you are fueling a machine. Do not smoke while you are fueling a machine. Do not fuel a machine near open flames or sparks. Do not use cell phones or other electronic devices while you are refueling. Always stop the engine before fueling. Fill the fuel tank outdoors. Properly clean areas of spillage.

Avoid static electricity risk when fueling. Ultra low sulfur diesel (ULSD) poses a greater static ignition hazard than earlier diesel formulations with a higher sulfur content. Avoid death or serious injury from fire or explosion. Consult with your fuel or fuel system supplier to ensure that the delivery system is in compliance with fueling standards for proper grounding and bonding practices.

Never store flammable fluids in the operator compartment of the machine.

## Battery and Battery Cables



Illustration 43

g03839133

Caterpillar recommends the following in order to minimize the risk of fire or an explosion related to the battery.

Do not operate a machine if battery cables or related parts show signs of wear or damage. Contact your Cat dealer for service.

Follow safe procedures for engine starting with jump-start cables. Improper jumper cable connections can cause an explosion that may result in injury. Refer to Operation and Maintenance Manual, "Engine Starting with Jump Start Cables" for specific instructions.

Do not charge a frozen battery. This may cause an explosion.

Gases from a battery can explode. Keep any open flames or sparks away from the top of a battery. Do not smoke in battery charging areas. Do not use cell phones or other electronic devices in battery charging areas.

Never check the battery charge by placing a metal object across the terminal posts. Use a voltmeter in order to check the battery charge.

## Safety Section

### Fire Prevention and Explosion Prevention

Daily inspect battery cables that are in areas that are visible. Inspect cables, clips, straps, and other restraints for damage. Replace any damaged parts. Check for signs of the following, which can occur over time due to use and environmental factors:

- Fraying
- Abrasion
- Cracking
- Discoloration
- Cuts on the insulation of the cable
- Fouling
- Corroded terminals, damaged terminals, and loose terminals

Replace damaged battery cable(s) and replace any related parts. Eliminate any fouling, which may have caused insulation failure or related component damage or wear. Ensure that all components are reinstalled correctly.

An exposed wire on the battery cable may cause a short to ground if the exposed area comes into contact with a grounded surface. A battery cable short produces heat from the battery current, which may be a fire hazard.

An exposed wire on the ground cable between the battery and the disconnect switch may cause the disconnect switch to be bypassed if the exposed area comes into contact with a grounded surface. This may result in an unsafe condition for servicing the machine. Repair components or replace components before servicing the machine.

### WARNING

**Fire on a machine can result in personal injury or death. Exposed battery cables that come into contact with a grounded connection can result in fires. Replace cables and related parts that show signs of wear or damage. Contact your Cat dealer.**

## Wiring

Check electrical wires daily. If any of the following conditions exist, replace parts before you operate the machine.

- Fraying
- Signs of abrasion or wear
- Cracking
- Discoloration

- Cuts on insulation
- Other damage

Make sure that all clamps, guards, clips, and straps are reinstalled correctly. This will help to prevent vibration, rubbing against other parts, and excessive heat during machine operation.

Attaching electrical wiring to hoses and tubes that contain flammable fluids or combustible fluids should be avoided.

Consult your Cat dealer for repair or for replacement parts.

Keep wiring and electrical connections free of debris.

## Lines, Tubes, and Hoses

Do not bend high-pressure lines. Do not strike high-pressure lines. Do not install any lines that are bent or damaged. Use the appropriate backup wrenches in order to tighten all connections to the recommended torque.

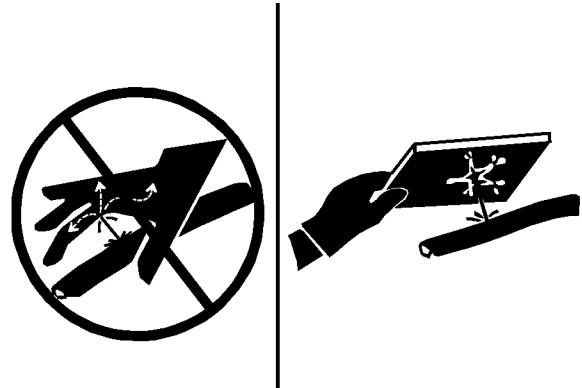

Illustration 44

g00687600

Check lines, tubes, and hoses carefully. Wear Personal Protection Equipment (PPE) in order to check for leaks. Always use a board or cardboard when you check for a leak. Leaking fluid that is under pressure can penetrate body tissue. Fluid penetration can cause serious injury and possible death. A pin hole leak can cause severe injury. If fluid is injected into your skin, you must get treatment immediately. Seek treatment from a doctor that is familiar with this type of injury.

Replace the affected parts if any of the following conditions are present:

- End fittings are damaged or leaking.
- Outer coverings are chafed or cut.
- Wires are exposed.
- Outer coverings are swelling or ballooning.
- Flexible parts of the hoses are kinked.

- Outer covers have exposed embedded armoring.
- End fittings are displaced.

Make sure that all clamps, guards, and heat shields are installed correctly. During machine operation, this will help to prevent vibration, rubbing against other parts, excessive heat, and failure of lines, tubes, and hoses.

Do not operate a machine when a fire hazard exists. Repair any lines that are corroded, loose, or damaged. Leaks may provide fuel for fires. Consult your Cat dealer for repair or for replacement parts. Use genuine Cat parts or the equivalent, for capabilities of both the pressure limit and temperature limit.

## Ether

Ether (if equipped) is commonly used in cold-weather applications. Ether is flammable and poisonous.

Only use approved Ether canisters for the Ether dispensing system fitted to your machine, do not spray Ether manually into an engine, follow the correct cold engine starting procedures. Refer to the section in the Operation and Maintenance Manual with the label "Engine Starting" .

Use ether in ventilated areas. Do not smoke while you are replacing an ether cylinder.

Do not store ether cylinders in living areas or in the operator compartment of a machine. Do not store ether cylinders in direct sunlight or in temperatures above 49° C (120.2° F). Keep ether cylinders away from open flames or sparks.

Dispose of used ether cylinders properly. Do not puncture an ether cylinder. Keep ether cylinders away from unauthorized personnel.

## Fire Extinguisher

As an additional safety measure, keep a fire extinguisher on the machine.

Be familiar with the operation of the fire extinguisher. Inspect the fire extinguisher and service the fire extinguisher regularly. Follow the recommendations on the instruction plate.

Consider installation of an aftermarket Fire Suppression System, if the application and working conditions warrant the installation.

i07041871

## Fire Safety

**SMCS Code:** 7000

**Note:** Locate secondary exits and how to use the secondary exits before you operate the machine.

**Note:** Locate fire extinguishers and how to use a fire extinguisher before you operate the machine.

If you find that you are involved in a machine fire, your safety and that of others on site are the top priority. The following actions should only be performed if the actions do not present a danger or risk to you and any nearby people. Assess the risk of personal injury and move away to a safe distance as soon as you feel unsafe.

Move the machine away from nearby combustible material such as fuel/oil stations, structures, trash, mulch, and timber.

Lower any implements and turn off the engine as soon as possible. If you leave the engine running, the engine will continue to feed a fire. The fire will be fed from any damaged hoses that are attached to the engine or pumps.

If possible, turn the battery disconnect switch to the OFF position. Disconnecting the battery will remove the ignition source in the event of an electrical short. Disconnecting the battery will eliminate a second ignition source if electrical wiring is damaged by the fire, resulting in a short circuit.

Notify emergency personnel of the fire and your location.

If your machine is equipped with a fire suppression system, follow the manufacturers procedure for activating the system.

**Note:** Fire suppression systems need to be regularly inspected by qualified personnel. You must be trained to operate the fire suppression system.

If you are unable to do anything else, shut off the machine before exiting. By shutting off the machine, fuels will not continue to be pumped into the fire.

If the fire grows out of control, be aware of the following risks:

- Tires on wheeled machines pose a risk of explosion as tires burn. Hot shrapnel and debris can be thrown great distances in an explosion.
- Tanks, accumulators, hoses, and fittings can rupture in a fire, spraying fuels and shrapnel over a large area.
- Remember that nearly all the fluids on the machine are flammable, including coolant and oils. Additionally, plastics, rubbers, fabrics, and resins in fiberglass panels are also flammable.

i01820946

## Fire Extinguisher Location

**SMCS Code:** 7000; 7419

Make sure that a fire extinguisher is on the machine. Make sure that you are familiar with the operation of the fire extinguisher. Inspect the fire extinguisher and service the fire extinguisher. Obey the recommendations on the instruction plate.

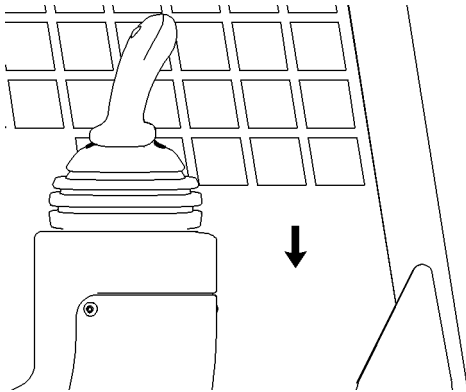

Illustration 45

g00929625

Mount the fire extinguisher on the left side of the cab floor in front of the console for the speed/direction control. Consult your Caterpillar dealer for the proper procedure for mounting the fire extinguisher.

i01122596

## Electrical Storm Injury Prevention

**SMCS Code:** 7000

When lightning is striking in the vicinity of the machine, the operator should never attempt the following procedures:

- Mount the machine.
- Dismount the machine.

If you are in the operator's station during an electrical storm, stay in the operator's station. If you are on the ground during an electrical storm, stay away from the vicinity of the machine.

i00771840

## Before Starting Engine

**SMCS Code:** 1000; 7000

Start the engine only from the operator compartment. Never short across the starter terminals or across the batteries. Shorting could damage the electrical system by bypassing the engine neutral start system.

Inspect the condition of the seat belt and of the mounting hardware. Replace any parts that are worn or damaged. Regardless of appearance, replace the seat belt after three years of use. Do not use a seat belt extension on a retractable seat belt.

Adjust the seat so that full pedal travel can be achieved with the operator's back against the back of the seat.

Make sure that the machine is equipped with a lighting system that is adequate for the job conditions. Make sure that all machine lights are working properly.

Before you start the engine and before you move the machine, make sure that no one is underneath the machine, around the machine, or on the machine. Make sure that the area is free of personnel.

i07717467

## Restricted Visibility

**SMCS Code:** 7000; 7605

The size and the configuration of this machine may result in areas that cannot be seen when the operator is seated. For restricted visibility areas, an appropriate job site organization must be utilized to minimize hazards of this restricted visibility. For more information regarding job site organization refer to Operation and Maintenance Manual, "Visibility Information".

Illustration 46 provides an approximate visual indication of the areas at ground level inside a radius of 12 m (39 ft) from the operator with restricted visibility. All restricted visibility areas less than 300mm wide may not be shown. This illustration does not indicate areas of restricted visibility for distances outside of the shown radius. The areas of restricted visibility shown in the illustration are with the work tool of the machine in the Travel position. The Travel position is worktool at lowest height and fully racked back.

Illustration 46 indicates restricted visibility areas at ground level inside the shown radius from the operator with the use of standard equipment and equipped with enclosed cab.

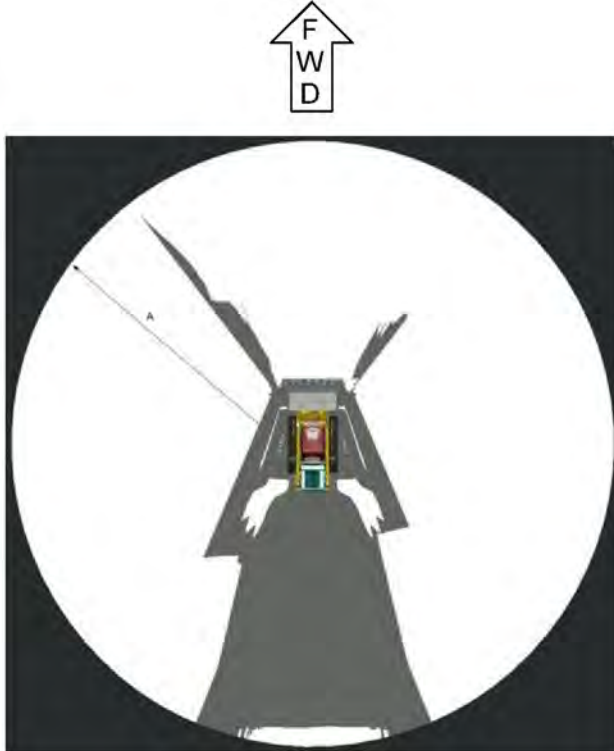

Illustration 46

g06338806

Top view of the machine, ground level visibility equipped with enclosed cab.

(A) 12 m (39 ft)

**Note:** The shaded areas indicate the approximate location of areas with significant restricted visibility.

i07746368

## Visibility Information

**SMCS Code:** 7000

Before you start the machine, perform a walk-around inspection in order to ensure that there are no hazards around the machine.

While the machine is in operation, constantly survey the area around the machine in order to identify potential hazards as hazards become visible around the machine.

Your machine may be equipped with visual aids. Some examples of visual aids are Closed Circuit Television (CCTV) and mirrors. Before operating the machine, ensure that the visual aids are in proper working condition and that the visual aids are clean. Adjust the visual aids using the procedures that are located in this Operation and Maintenance Manual. If equipped, the Work Area Vision System shall be adjusted according to Operation and Maintenance Manual, SEBU8157, "Work Area Vision System". If equipped, the Cat Detect Object Detection shall be adjusted according to the Operation and Maintenance Manual, "Cat Detect Object Detection" for your machine.

It may not be possible to provide direct visibility on large machines to all areas around the machine. Appropriate job site organization is required in order to minimize hazards that are caused by restricted visibility. Job site organization is a collection of rules and procedures that coordinates machines and people that work together in the same area. Examples of job site organization include the following:

- Safety instructions
- Controlled patterns of machine movement and vehicle movement
- Workers that direct safe movement of traffic
- Restricted areas
- Operator training
- Warning symbols or warning signs on machines or on vehicles
- A system of communication
- Communication between workers and operators prior to approaching the machine

Modifications of the machine configuration by the user that result in a restriction of visibility shall be evaluated.

i07327729

## Engine Starting

**SMCS Code:** 1000; 7000

If a warning tag is attached to the start switch or to the controls, do not start the engine. Also, do not move any controls.

Move all hydraulic controls to the NEUTRAL position before you start the engine.

Set the engine speed control knob to the low idle position before you start the engine. See Operation Maintenance Manual, Engine Starting for specific engine starting and warm up procedures, and an explanation of several engine protection modes that may be active under certain conditions which might impact the expected or desired engine speed.

Diesel engine exhaust contains products of combustion which can be harmful to your health. Always start the engine in a well ventilated area. Always operate the engine in a well ventilated area. If you are in an enclosed area, vent the exhaust to the outside.

i02552731

## Before Operation

**SMCS Code:** 7000

Video tapes and safety information are available in English for the machine. A list of some of the material is available in the Operation and Maintenance Manual, "Reference Material". Consult your Caterpillar dealer in order to obtain copies of the material. The information should be reviewed by every person that operates the machine.

Clear all personnel from the machine and from the area.

Clear all obstacles from the path of the machine. Beware of hazards such as wires, ditches, etc.

Make sure that all windows are clean. Secure all doors in the closed position. Secure the windows in the open position or in the shut position.

Make sure that the machine horn, the backup alarm and all other warning devices are working properly.

Fasten the seat belt securely. Lower the armrest.

i07776634

## Operation

**SMCS Code:** 7000

Only operate the machine while you are in the seat. The seat belt must be fastened while you operate the machine. Only operate the controls while the engine is running.

Before you move the machine, you must be certain that no one will be endangered.

While you operate the machine and the work tool slowly in an open area, check for proper operation of all controls and all protective devices.

Do not allow riders on the machine. Never use the work tool for a work platform.

Note any needed repairs during machine operation. Report any needed repairs.

Use only Caterpillar Approved Work Tools on this machine. Obey all the lift restrictions. Refer to Operation and Maintenance Manual, "Caterpillar Approved Work Tools" for the approved work tools and the lift restriction information.

Carry work tools low. Lower the lift arms fully. Tilt back the work tool to keep the work tool off the ground. Do not go close to the edge of a cliff, an excavation, or an overhang.

If the machine begins to sideslip downward on a grade, immediately remove the load and turn the machine downhill.

Avoid any conditions that can lead to tipping the machine. The machine can tip when you work on banks and on slopes. Also, the machine can tip when you cross ditches, ridges, or other unexpected obstacles. Never exceed a slope that is greater than 3 to 1 (18.4 degrees).

Maintain control of the machine. Do not overload the machine beyond the machine capacity.

Never straddle a wire cable. Never allow personnel to straddle a wire cable.

Know the maximum dimensions of your machine.

Always keep the Rollover Protective Structure (ROPS) installed during machine operation.

Machine Operating Temperature Range. The machine must function satisfactorily in the anticipated ambient temperature limits that are encountered during operation. The minimum limits of items that will affect the safe operation of the machine to be considered are 0-100% relative humidity for -32 °C (-25 °F) to 43 °C (109.4 °F) temperatures unless specified in the functional specifications.

Observe any local government regulations when you use the machine to lift heavy objects.

## Limiting Conditions and Criteria

Limiting conditions are immediate issues with this machine that must be addressed prior to continuing operation.

The Operation and Maintenance Manual, Safety Section describes limiting condition criteria for replacing items such as safety messages, seat belt and mounting hardware, lines, tubes, hoses, battery cables and related parts, electrical wires, and repairing any fluid leak.

The Operation and Maintenance Manual, Maintenance Interval Schedule describes limiting condition criteria that require repair or replacement for items (if equipped) such as alarms, horns, braking system, steering system, and rollover protective structures.

The Operation and Maintenance Manual, Monitoring System (if equipped) provides information on limiting condition criteria, including a Warning Category 3 that requires immediate shutdown of the engine.

The following table provides summary information on several limiting conditions found in this Operation and Maintenance Manual. The table provides criteria and required action for the limiting conditions listed. Each System or Component in this table, together with the respective limiting condition, describes a potential critical failure that must be addressed. Not addressing limiting conditions with required actions may, in conjunction with other factors or circumstances, result in a risk of personal injury or death. If an accident occurs, notify emergency personnel and provide location and description of accident.

Table 1

| System or Component Name                | Limiting Condition  | Criteria for Action  | Required Action  |
|---|---|--|--|
| Line, tubes, and hoses                  | End fittings are damaged or leaking. Outer coverings are chafed or cut. Wires are exposed. Outer coverings are swelling or ballooning. Flexible parts of the hoses are kinked. Outer covers have exposed embedded armoring. End fittings are displaced. | Visible corrosion, loose, or damaged lines, tubes, or hoses. Visible fluid leaks.                                    | Immediately repair any lines, tubes, or hoses that are corroded, loose, or damaged. Immediately repair any leaks as these may provide fuel for fires.        |
| Electrical Wiring                       | Signs of fraying, abrasion, cracking, discoloration, cuts on the insulation   | Visible damage to electrical wiring  | Immediately replace damaged wiring   |
| Battery cable(s)                        | Signs of fraying, abrasion, cracking, discoloration, cuts on the insulation of the cable, fouling, corroded terminals, damaged terminals, and loose terminals   | Visible damage to battery cable(s)   | Immediately replace damaged battery cables   |
| Operator Protective Structure           | Structures that are bent, cracked, or loose. Loose, missing, or damaged bolts.  | Visible damage to structure. Loose, missing, or damaged bolts.   | Do not operate machine with damaged structure or loose, missing, or damaged bolts. Contact your Cat dealer for inspection and repair or replacement options. |
| Seat Belt                               | Worn or damaged seat belt or mounting hardware  | Visible wear or damage   | Immediately replace parts that are worn or damaged.  |
| Seat Belt                               | Age of seat belt  | Three years after date of installation   | Replace seat belt three years after date of installation   |
| Safety Messages                         | Appearance of safety message  | Damage to safety messages making them illegible  | Replace the illustrations if illegible.  |
| Audible Warning Device(s) (if equipped) | Sound level of audible warning  | Reduced or no audible warning present  | Immediately repair or replace audible warning devices not working properly.  |
| Camera(s) (if equipped)                 | Dirt or debris on camera lens   | Dirt or debris obstructing camera view   | Clean camera before operating machine.   |
| Cab Windows (if equipped)               | Dirt, debris, or damaged windows  | Dirt or debris obstructing operator visibility. Any damaged windows.   | Clean windows before operating machine. Repair or replace damaged windows before operating machine.  |
| Mirrors (if equipped)                   | Dirt, debris, or damaged mirror   | Dirt or debris obstructing operator visibility. Any damaged mirrors.   | Clean mirrors before operating machine. Repair or replace damaged mirrors before operating machine.  |
| Braking System                          | Inadequate braking performance  | System does not pass Braking System - Test(s) included in Maintenance Section or in the Testing and Adjusting Manual | Contact your Cat dealer to inspect and, if necessary, repair the brake system.   |

(continued)

(Table 1, contd)

| System or Component Name | Limiting Condition   | Criteria for Action                           | Required Action  |
|--------------------------|--|---|--|
| Cooling System           | The coolant temperature is too high.   | Monitoring System displays Warning Category 3 | Stop the engine immediately. Check the coolant level and check the radiator for debris. Refer to Operation and Maintenance Manual, Cooling System Coolant Level - Check. Check the fan drive belts for the water pump. Refer to Operation and Maintenance Manual, Belts - Inspect/Adjust/ Replace. Make any necessary repairs. |
| Engine Oil System        | A problem has been detected with the engine oil pressure.  | Monitoring System displays Warning Category 3 | If the warning stays on during low idle, stop the engine and check the engine oil level. Perform any necessary repairs as soon as possible.  |
| Engine system            | An engine fault has been detected by the engine ECM.   | Monitoring System displays Warning Category 3 | Stop the engine immediately. Contact your Cat dealer for service.  |
| Fuel System              | A problem has been detected with the fuel system.  | Monitoring System displays Warning Category 3 | Stop the engine. Determine the cause of the fault and perform any necessary repairs.   |
| Hydraulic Oil System     | The hydraulic oil temperature is too high.   | Monitoring System displays Warning Category 3 | Stop the engine immediately. Check the hydraulic oil level and check the hydraulic oil cooler for debris. Perform any necessary repairs as soon as possible.   |
| Steering System          | A problem has been detected with the steering system. (If equipped with steering system monitoring.) | Monitoring System displays Warning Category 3 | Move machine to a safe location and stop the engine immediately. Contact your Cat dealer to inspect and, if necessary, repair the steering system.   |
| Overall Machine          | Machine service is required.   | Monitoring System displays Warning Category 3 | Stop the engine immediately. Contact your Cat dealer for service.  |

i01115299

i06158704

## Work Tools

**SMCS Code:** 6700

Only use work tools that are approved by Caterpillar for use on Caterpillar machines. Refer to the Operation and Maintenance Manual, "Caterpillar Approved Work Tools".

If you are in doubt about the compatibility of a particular work tool with your machine, consult your Caterpillar dealer.

Make sure that all necessary guarding is in place on the host machine and on the work tool.

Keep all windows and doors closed on the host machine. Always wear protective glasses. Always wear the protective equipment that is recommended in the work tool's operation manual. Wear any other protective equipment that is required for the operating environment.

To prevent personnel from being struck by flying objects, ensure that all personnel are out of the work area.

While you are performing any maintenance, any testing, or any adjustments to the work tool stay clear of the following areas: cutting edges, pinching surfaces and crushing surfaces.

## Demolition

**SMCS Code:** 6700

There may be local regulations and/or government regulations that govern the use of machines which are designed and used as demolition machinery.

**Note:** Obey all local and government regulations.

Demolition machinery is designed for demolishing by pushing or pulling, or fragmenting. Demolition is done by crushing or shearing, buildings and/or other civil engineering structures and component parts and/or separating the resultant debris.

If this machine is used as a demolition machine, within an area that is controlled by the European Directive 2006/42/EC the machine must be equipped with:

- Polycarbonate Front Door
- FOPS Level II
- Camera, Rear View, and Display

**Note:** This machine may require additional options to operate demolition tools such as a hammer or a shear within the EU. Contact your Cat dealer for additional information.

Demolition applications may generate flying debris. Ensure that there are no personnel in the area around the machine where flying debris may travel.

Demolition applications may generate airborne dust that can be hazardous to your health. If you operate the machine in a dust generating applications, use appropriate safeguarding or adequate ventilation to minimize risk.

i02518481

## Parking

**SMCS Code:** 7000

Park on a level surface. If you must park on a grade, chock the machine.

1. Move the joystick control slowly to the NEUTRAL position in order to stop the machine.
2. Move the governor control lever to the LOW IDLE position.
3. Lower the loader arms and tilt the linkage so that the work tool rests firmly on the ground.
4. Move the hydraulic controls to the NEUTRAL position.
5. Turn the engine start switch key to OFF position and remove the key.
6. Raise the armrests and exit the machine.

i07746366

## Slope Operation

**SMCS Code:** 7000

Machines that are operating safely in various applications depend on these criteria: the machine model, configuration, machine maintenance, operating speed of the machine, conditions of the terrain, fluid levels, and tire inflation pressures. The most important criteria are the skill and judgment of the operator.

A well trained operator that follows the instructions in the Operation and Maintenance Manual has the greatest impact on stability. Operator training provides a person with the following abilities: observation of working and environmental conditions, feel for the machine, identification of potential hazards and operating the machine safely by making appropriate decisions.

When you work on side hills and when you work on slopes, consider the following important points:

**Speed of travel** – At higher speeds, forces of inertia tend to make the machine less stable.

**Roughness of terrain or surface** – The machine may be less stable with uneven terrain.

**Direction of travel** – Avoid operating the machine across the slope. When possible, operate the

machine up the slopes and operate the machine down the slopes. Place the heaviest end of the machine uphill when you are working on an incline.

**Mounted equipment** – Balance of the machine may be impeded by the following components: equipment that is mounted on the machine, machine configuration, weights, and counterweights.

**Nature of surface** – Ground that has been newly filled with earth may collapse from the weight of the machine.

**Surface material** – Rocks and moisture of the surface material may drastically affect the machine's traction and machine's stability. Rocky surfaces may promote side slipping of the machine.

**Slippage due to excessive loads** – This may cause downhill tracks or downhill tires to dig into the ground, which will increase the angle of the machine.

**Width of tracks or tires** – Narrower tracks or narrower tires further increase the digging into the ground which causes the machine to be less stable.

**Implements attached to the drawbar** – This may decrease the weight on the uphill tracks. This may also decrease the weight on the uphill tires. The decreased weight will cause the machine to be less stable.

**Height of the working load of the machine** – When the working loads are in higher positions, the stability of the machine is reduced.

**Operated equipment** – Be aware of performance features of the equipment in operation and the effects on machine stability.

**Operating techniques** – Keep all attachments or pulled loads low to the ground for optimum stability.

**Machine systems have limitations on slopes** – Slopes can affect the proper function and operation of the various machine systems. These machine systems are needed for machine control.

**Note:** Operators with lots of experience and proper equipment for specific applications are also required. Safe operation on steep slopes may also require special machine maintenance. Refer to Lubricant Viscosities and Refill Capacities in this manual for the proper fluid level requirements and intended machine use. Fluids must be at the correct levels to ensure that systems will operate properly on a slope.

i01329161

## Equipment Lowering with Engine Stopped

**SMCS Code:** 7000

Before lowering any equipment with the engine stopped, clear the area around the equipment of all personnel. The procedure to use will vary with the type of equipment to be lowered. Keep in mind most systems use a high pressure fluid or air to raise or lower equipment. The procedure will cause high pressure air, hydraulic, or some other media to be released in order to lower the equipment. Wear appropriate personal protective equipment and follow the established procedure in the Operation and Maintenance Manual, "Equipment Lowering with Engine Stopped" in the Operation Section of the manual.

i07776654

## Sound Information and Vibration Information

**SMCS Code:** 7000

### Sound Level Information

The operator Equivalent Sound Pressure Level is 89 dB(A) when "ANSI/SAE J1166 Feb 2008" is used to measure the value for an enclosed cab. This is a work cycle sound exposure level. The cab was properly installed and maintained. The test was conducted with the cab doors and the cab windows closed.

Hearing protection may be needed when the machine is operated with an open operator station for extended periods or in a noisy environment. Hearing protection may be needed when the machine is operated with a cab that is not properly maintained or when the doors and windows are open for extended periods or in a noisy environment.

For Skid Steer Loader models 216B3, 226B3, 236B3, 242B3, and 252B3 the average exterior sound pressure level is 72 dB(A) when the "SAE J88Feb2006 - Constant Speed Moving Test" procedure is used to measure the value for the standard machine. The measurement was conducted under the following conditions: distance of 15 m (49.2 ft) and "the machine moving forward in an intermediate gear ratio".

For Multi Terrain Loader and Compact Track Loader models 247B3, 257B3 and 259B3 the average exterior sound pressure level is 75 dB(A) when the "SAE J88Feb2006 - Constant Speed Moving Test" procedure is used to measure the value for the standard machine. The measurement was conducted under the following conditions: distance of 15 m (49.2 ft) and "the machine moving forward in an intermediate gear ratio".

### Sound Level Information for Machines in European Union Countries and in Countries that Adopt the "EU Directives"

The dynamic operator sound pressure level is 89 dB(A) when "ISO 6396:2008" is used to measure the value for an enclosed cab. The cab was properly installed and maintained. The test was conducted with the cab doors and the cab windows closed.

The average exterior sound power level for Skid Steer Loader models 216B3, 226B3, 236B3, and 242B3 is 101 dB(A) when the "ISO 6395 - Dynamic Test" procedure is used to measure the value for the standard machine.

The average exterior sound power level for Multi Terrain Loader and Compact Track Loader models 247B3, 257B3, and 259B3 is 103 dB(A) when the "ISO 6395 - Dynamic Test" procedure is used to measure the value for the standard machine.

### Sound Level Information for Machines in Eurasian Economic Union Countries

The declared dynamic operator sound pressure level is 89 dB(A) when "ISO 6396:2008" is used to measure the value for an enclosed cab. The measurement was conducted at 70 % of the maximum engine cooling fan speed. The sound level may vary at different engine cooling fan speeds. The measurement was conducted with the cab doors and the cab windows closed.

The declared exterior sound power level (LWA) for Skid Steer Loader models 216B3, 226B3, 236B3, and 242B3 is 101 dB(A) when the value is measured according to the dynamic test procedures and the conditions that are specified in "ISO 6395:2008". The measurement was conducted at 70 % of the maximum engine cooling fan speed. The sound level may vary at different engine cooling fan speeds.

The declared exterior sound power level (LWA) for Multi Terrain Loader and Compact Track Loader models 247B3, 257B3, and 259B3 is 103 dB(A) when the value is measured according to the dynamic test procedures and the conditions that are specified in "ISO 6395:2008". The measurement was conducted at 70 % of the maximum engine cooling fan speed. The sound level may vary at different engine cooling fan speeds.

The declared sound levels listed above include both measurement uncertainty and uncertainty due to production variation.

### **“The European Union Physical Agents (Vibration) Directive 2002/44/EC”**

Measurements are obtained on a standard arrangement machine using operation and measurement procedures set forth in the following standards:

- “SAE J1166:2008 Sound Measurement - Off-Road Self-propelled Work Machines Operator - Work Cycle. Section 10.2 (Wheel Loader)”
- “ISO 2631-1:1997 Evaluation of Human Exposure to Whole Body Vibration Part 1:General Requirements”
- “ISO 5349-1:2001 Mechanical vibration - Measurement and evaluation of human exposure to hand-transmitted vibration. Part 1: General requirements.”

### **Vibration Data for Skid Steer Loaders**

The operator of this machine should expect to be exposed to vibration levels below when using the machine in the performance of it normally intended function:

#### **Hand/Arm Vibration Level**

Does not exceed 2.5m/s<sup>2</sup>. This value is the representative value of the vibration total value (root sum of squares acceleration value) to which the hand and arms are subjected.

#### **Whole Body Vibration Level**

Does not exceed 1.1 m/s<sup>2</sup>. This value is the representative value of the maximum directional weighted root mean square acceleration to which the whole body is subjected.

### **Vibration Data for Multi Terrain Loader**

The operator of this machine should expect to be exposed to vibration levels below when using the machine in the performance of it normally intended function:

#### **Hand/Arm Vibration Level**

Does not exceed 2.5m/s<sup>2</sup>. This value is the representative value of the vibration total value (root sum of squares acceleration value) to which the hand and arms are subjected.

#### **Whole Body Vibration Level**

Does not exceed 1.7 m/s<sup>2</sup>. This value is the representative value of the maximum directional weighted root mean square acceleration to which the whole body is subjected.

### **Vibration Data for Compact Track Loaders**

The operator of this machine should expect to be exposed to vibration levels below when using the machine in the performance of it normally intended function:

#### **Hand/Arm Vibration Level**

Does not exceed 3.2m/s<sup>2</sup>. This value is the representative value of the vibration total value (root sum of squares acceleration value) to which the hand and arms are subjected.

#### **Whole Body Vibration Level**

Does not exceed 2.1m/s<sup>2</sup>. This value is the representative value of the maximum directional weighted root mean square acceleration to which the whole body is subjected.

### **Information Concerning Whole Body Vibration Level**

This section provides vibration data and a method for estimating the vibration level for skid steer loaders.

**Note:** Vibration levels are influenced by many different parameters. Many items are listed below.

- Operator training, behavior, mode, and stress
- Job site organization, preparation, environment, weather, and material
- Machine type, quality of the seat, quality of the suspension system, attachments, and condition of the equipment

Precise vibration levels for this machine are not possible. The expected vibration levels can be estimated with the information in Table 2 to calculate the daily vibration exposure. A simple evaluation of the machine application can be used.

Estimate the vibration levels for the three vibration directions. For typical operating conditions, use the average vibration levels as the estimated level. With an experienced operator and smooth terrain, subtract the Scenario Factors from the average vibration level to obtain the estimated vibration level. For aggressive operations and severe terrain, add the Scenario Factors to the average vibration level to obtain the estimated vibration level.

**Note:** All vibration levels are in meter per second squared.

Table 2

| "ISO Reference Table A - Equivalent vibration levels of whole body vibration emission for earthmoving equipment." |                            |                  |        |        |                  |        |        |
|---|----------------------------|------------------|--------|--------|------------------|--------|--------|
| Machine Type  | Typical Operating Activity | Vibration Levels |        |        | Scenario Factors |        |        |
|   |                            | X axis           | Y axis | Z axis | X axis           | Y axis | Z axis |
| Skid Steer Loader   | load and carry motion      | 0.7              | 0.5    | 0.7    | 0.30             | 0.33   | 0.35   |
| Multi Terrain Loader  | v-shape motion             | 0.9              | 0.5    | 0.13   | 0.30             | 0.84   | 0.32   |
| Compact Track Loader  | v-shape motion             | 1.2              | 1.6    | 0.8    | 0.30             | 0.84   | 0.32   |

**Note:** Refer to "ISO/TR 25398 Mechanical Vibration - Guideline for the assessment of exposure to whole body vibration of ride on operated earthmoving machines" for more information about vibration. This publication uses data that is measured by international institutes, organizations, and manufacturers. This document provides information about the whole body exposure of operators of earthmoving equipment. Refer to Operation and Maintenance Manual, SEBU8257, "The European Union Physical Agents (Vibration) Directive 2002/44/EC" for more information about machine vibration levels.

The Caterpillar suspension seat meets the criteria of "ISO 7096". This represents vertical vibration level under severe operating conditions. This seat is tested with the input "spectral class EM9". The seat has a transmissibility factor of "SEAT<0.9".

The whole body vibration level of the machine varies. There is a range of values. The low value is 0.5 m/s<sup>2</sup>. The machine meets the short-term level for the design of the seat in "ISO 7096". The value is 1.59 m/s<sup>2</sup> for this machine.

### Guidelines for Reducing Vibration Levels on Earthmoving Equipment

Properly adjust machines. Properly maintain machines. Operate machines smoothly. Maintain the conditions of the terrain. The following guidelines can help reduce the whole body vibration level:

1. Use the right type and size of machine, equipment, and attachments.
2. Maintain machines according to the manufacturers recommendations.

- a. Tire pressures
- b. Brake and steering systems
- c. Controls, hydraulic system, and linkages
3. Keep the terrain in good condition.
  - a. Remove any large rocks or obstacles.
  - b. Fill any ditches and holes.
  - c. Provide machines and schedule time to maintain the conditions of the terrain.
4. Use a seat that meets "ISO 7096". Keep the seat maintained and adjusted.
  - a. Adjust the seat and suspension for the weight and the size of the operator.
  - b. Inspect and maintain the seat suspension and adjustment mechanisms.
5. Perform the following operations smoothly.
  - a. Steer
  - b. Brake
  - c. Accelerate.
  - d. Shift the gears.
6. Move the attachments smoothly.
7. Adjust the machine speed and the route to minimize the vibration level.
  - a. Drive around obstacles and rough terrain.
  - b. Slow down when necessary to go over rough terrain.

8. Minimize vibrations for a long work cycle or a long travel distance.
  - a. Use machines that are equipped with suspension systems.
  - b. Use the ride control system on skid steer loaders.
  - c. If no ride control system is available, reduce speed to prevent bounce.
  - d. Haul the machines between workplaces.
9. Less operator comfort may be caused by other risk factors. The following guidelines can be effective to provide better operator comfort:
  - a. Adjust the seat and adjust the controls to achieve good posture.
  - b. Adjust the mirrors to minimize twisted posture.
  - c. Provide breaks to reduce long periods of sitting.
  - d. Avoid jumping from the cab.
  - e. Minimize repeated handling of loads and lifting of loads.
  - f. Minimize any shocks and impacts during sports and leisure activities.

## Sources

The vibration information and calculation procedure is based on "ISO/TR 25398 Mechanical Vibration - Guideline for the assessment of exposure to whole body vibration of ride on operated earthmoving machines". Harmonized data is measured by international institutes, organizations, and manufacturers.

This literature provides information about assessing the whole body vibration exposure of operators of earthmoving equipment. The method is based on measured vibration emission under real working conditions for all machines.

Check the original directive. This document summarizes part of the content of the applicable law. This document is not meant to substitute the original sources. Other parts of these documents are based on information from the United Kingdom Health and Safety Executive.

Refer to Operation and Maintenance Manual, SEBU8257, "The European Union Physical Agents (Vibration) Directive 2002/44/EC" for more information about vibration.

Consult your local Caterpillar dealer for more information about machine features that minimize vibration levels. Consult your local Caterpillar dealer about safe machine operation.

Use the following web site to find your local dealer:

Caterpillar, Inc.  
www.cat.com

i05753797

## Guards (Operator Protection)

**SMCS Code:** 7150-MCH; 7325

There are different types of guards that are used to protect the operator. The machine and the machine application, determines the type of guard that should be used.

A daily inspection of the guards is required in order to check for structures that are bent, cracked, or loose. Never operate a machine with a damaged structure.

The operator becomes exposed to a hazardous situation if the machine is used improperly or if poor operating techniques are used. This situation can occur even though a machine is equipped with an appropriate protective guard. Follow the established operating procedures that are recommended for your machine.

## Roll over Protective Structure (ROPS), Falling Object Protective Structure (FOPS) or Tip Over Protection Structure (TOPS)

The ROPS/FOPS Structure (if equipped) on your machine is specifically designed, tested, and certified for that machine. Any alteration or any modification to the ROPS/FOPS Structure could weaken the structure. This action places the operator into an unprotected environment. Modifications or attachments that cause the machine to exceed the weight that is stamped on the certification plate also place the operator into an unprotected environment. Excessive weight may inhibit the brake performance, the steering performance, and the ROPS. The protection that is offered by the ROPS/FOPS Structure will be impaired if the ROPS/FOPS Structure has structural damage. Damage to the structure can be caused by an overturn, a falling object, a collision, .

Do not mount items (fire extinguishers, first aid kits, work lights). By welding brackets to the ROPS/FOPS Structure or by drilling holes in the ROPS/FOPS Structure. Welding brackets or drilling holes in the ROPS/FOPS Structures can weaken the structures. Consult your Caterpillar dealer for mounting guidelines.

The Tip Over Protection Structure (TOPS) is another type of guard that is used on mini hydraulic excavators. This structure protects the operator in the event of a tipover. The same guidelines for the inspection, the maintenance, and the modification of the ROPS/FOPS Structure are required for the Tip Over Protection Structure.

## **Other Guards (If Equipped)**

Protection from flying objects and/or falling objects is required for special applications. Logging applications and demolition applications are two examples that require special protection.

A front guard needs to be installed when a work tool that creates flying objects is used. Mesh front guards that are approved by Caterpillar or polycarbonate front guards that are approved by Caterpillar are available for machines with a cab or an open canopy. On machines that are equipped with cabs, the windows should also be closed. Safety glasses are recommended when flying hazards exist for machines with cabs and machines with open canopies.

If the work material extends above the cab, top guards and front guards should be used. Typical examples of this type of application are listed below:

- Demolition applications
- Rock quarries
- Forestry products

Additional guards may be required for specific applications or work tools. The Operation and Maintenance Manual for your machine or your work tool will provide specific requirements for the guards. Refer to Operation Maintenance manual, "Demolition" for additional information. Consult your Caterpillar dealer for additional information.

## Product Information Section

## General Information

i04399594

### Rated Load

SMCS Code: 6001; 6136; 6542; 7000

#### **! WARNING**

Failure to comply to the rated load can cause possible personal injury or property damage. Review the rated load of a particular work tool before performing any operation. Make adjustments to the rated load as necessary for non-standard configurations.

**Note:** Rated loads should be used as a guide. Attachments, uneven ground conditions, soft ground conditions, or poor ground conditions have effects on rated loads. The operator is responsible for being aware of these effects.

**Note:** "NR" in the table means that the tool is not recommended for the machine.

#### **! WARNING**

Machine stability is affected by many factors, including the type of work tool and the position of a work tool.

Machine stability and machine control can be significantly affected if a work tool is not installed. Operating a machine without a work tool can lead to loss of control or tipping of the machine which could result in serious injury or death.

When you operate a machine without a work tool, avoid the following conditions:

- excessive speed
- sharp turns
- abrupt implement movement
- slopes and uneven ground

Rated loads will vary with different attachments. Consult your Cat dealer regarding the rated load for specific attachments.

### Bucket Rated Load

The Rated Operating Capacity (ROC) is defined by the SAE standard "SAE J818 -2007", "EN 474-3:2006" and "ISO 14397-1:2007". The rated operating capacity is the least amount of weight of the following conditions:

- 35% of the full static tipping load on a surface that is soft or a surface that is uneven (applies to track machines only)
- 50% of the full static tipping load on a surface that is hard, smooth and level
- 100% of the lifting capacity

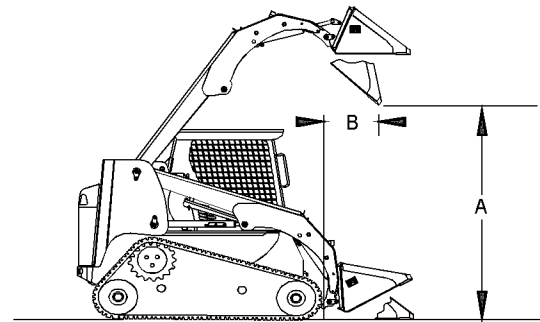

Illustration 47

g02125200

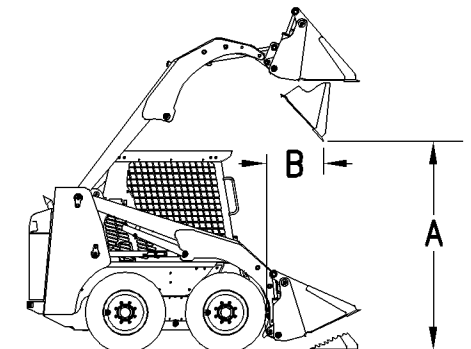

Illustration 48

g00554925

Dimension (A) represents the dump clearance.

Dimension (B) represents the reach.

The following tables provide the rated operating capacity (R.O.C.) for the standard machine that is equipped with the following:

- Full fuel tank and lubricants
- 75 kg (165 lb) operator
- Cat bucket

Product Information Section  
Rated Load

- 10x16.5 tires on the following machines: 216B3 and 226B3
- 12x16.5 tires on the following machines: 236B3, 242B3 and 252B3

Table 3

| General Purpose Buckets |                       |          |         |          |         |          |         |          |         |
|-------------------------|-----------------------|----------|---------|----------|---------|----------|---------|----------|---------|
|                         | P/N                   | 279-5364 |         | 279-5368 |         | 279-5372 |         | 279-5376 |         |
|                         | <b>Weight</b>         | 173 kg   | 381 lb  | 221 kg   | 487 lb  | 234 kg   | 516 lb  | 247 kg   | 544 lb  |
| <b>Models</b>           | <b>Bucket</b>         | 1524 mm  | 60 in   | 1676 mm  | 66 in   | 1829 mm  | 72 in   | 1981 mm  | 78 in   |
| <b>216B3</b>            | <b>R.O.C. 50%</b>     | 629 kg   | 1387 lb | 604 kg   | 1331 lb | NR       | NR      | NR       | NR      |
|                         | <b>Dump Clearance</b> | 2113 mm  | 83 in   | 2113 mm  | 83 in   | NR       | NR      | NR       | NR      |
|                         | <b>Reach</b>          | 609 mm   | 24 in   | 609 mm   | 24 in   | NR       | NR      | NR       | NR      |
| <b>226B3</b>            | <b>R.O.C. 50%</b>     | 668 kg   | 1473 lb | 643 kg   | 1417 lb | NR       | NR      | NR       | NR      |
|                         | <b>Dump Clearance</b> | 2113 mm  | 83 in   | 2113 mm  | 83 in   | NR       | NR      | NR       | NR      |
|                         | <b>Reach</b>          | 609 mm   | 24 in   | 609 mm   | 24 in   | NR       | NR      | NR       | NR      |
| <b>242B3</b>            | <b>R.O.C. 50%</b>     | 981 kg   | 2164 lb | 956 kg   | 2107 lb | 949 kg   | 2092 lb | NR       | NR      |
|                         | <b>Dump Clearance</b> | 2362 mm  | 93 in   | 2362 mm  | 93 in   | 2362 mm  | 93 in   | NR       | NR      |
|                         | <b>Reach</b>          | 811 mm   | 32 in   | 811 mm   | 32 in   | 811 mm   | 32 in   | NR       | NR      |
| <b>236B3</b>            | <b>R.O.C. 50%</b>     | 852 kg   | 1878 lb | 843 kg   | 1858 lb | 838 kg   | 1847 lb | 831 kg   | 1832 lb |
|                         | <b>Dump Clearance</b> | 2336 mm  | 92 in   | 2336 mm  | 92 in   | 2336 mm  | 92 in   | 2336 mm  | 92 in   |
|                         | <b>Reach</b>          | 596 mm   | 23 in   | 596 mm   | 23 in   | 596 mm   | 23 in   | 596 mm   | 23 in   |
| <b>252B3</b>            | <b>R.O.C. 50%</b>     | 1206 kg  | 2659 lb | 1195 kg  | 2635 lb | 1191 kg  | 2626 lb | 1183 kg  | 2608 lb |
|                         | <b>Dump Clearance</b> | 2426 mm  | 96 in   | 2426 mm  | 96 in   | 2426 mm  | 96 in   | 2426 mm  | 96 in   |
|                         | <b>Reach</b>          | 857 mm   | 34 in   | 857 mm   | 34 in   | 857 mm   | 34 in   | 857 mm   | 34 in   |
| <b>247B3</b>            | <b>R.O.C. 35%</b>     | 662 kg   | 1459 lb | 644 kg   | 1421 lb | 640 kg   | 1411 lb | 635 kg   | 1400 lb |
|                         | <b>Dump Clearance</b> | 1935 mm  | 76 in   | 1935 mm  | 76 in   | 1935 mm  | 76 in   | 1935 mm  | 76 in   |
|                         | <b>Reach</b>          | 737 mm   | 29 in   | 737 mm   | 29 in   | 737 mm   | 29 in   | 737 mm   | 29 in   |
| <b>257B3</b>            | <b>R.O.C. 35%</b>     | 826 kg   | 1822 lb | 808 kg   | 1783 lb | 804 kg   | 1772 lb | 799 kg   | 1762 lb |
|                         | <b>Dump Clearance</b> | 2264 mm  | 89 in   | 2264 mm  | 89 in   | 2264 mm  | 89 in   | 2264 mm  | 89 in   |
|                         | <b>Reach</b>          | 790 mm   | 31 in   | 790 mm   | 31 in   | 790 mm   | 31 in   | 790 mm   | 31 in   |
| <b>259B3</b>            | <b>R.O.C. 35%</b>     | 911 kg   | 2008 lb | 893 kg   | 1968 lb | 888 kg   | 1958 lb | 883 kg   | 1947 lb |
|                         | <b>Dump Clearance</b> | 2244 mm  | 88 in   | 2244 mm  | 88 in   | 2244 mm  | 88 in   | 2244 mm  | 88 in   |
|                         | <b>Reach</b>          | 740 mm   | 29 in   | 740 mm   | 29 in   | 740 mm   | 29 in   | 740 mm   | 29 in   |

Table 4

| Multipurpose Buckets |                       |          |         |          |         |          |         |          |         |
|----------------------|-----------------------|----------|---------|----------|---------|----------|---------|----------|---------|
|                      | P/N                   | 279-5382 |         | 279-5390 |         | 279-5398 |         | 279-5403 |         |
|                      | <b>Weight</b>         | 335 kg   | 738 lb  | 355 kg   | 782 lb  | 374 kg   | 824 lb  | 393 kg   | 866 lb  |
| <b>Models</b>        | <b>Bucket</b>         | 1524 mm  | 60 in   | 1676 mm  | 66 in   | 1829 mm  | 72 in   | 1981 mm  | 78 in   |
| <b>216B3</b>         | <b>R.O.C. 50%</b>     | 544 kg   | 1199 lb | 533 kg   | 1175 lb | NR       | NR      | NR       | NR      |
|                      | <b>Dump Clearance</b> | 2106 mm  | 83 in   | 2106 mm  | 83 in   | NR       | NR      | NR       | NR      |
|                      | <b>Reach</b>          | 613 mm   | 24 in   | 613 mm   | 24 in   | NR       | NR      | NR       | NR      |
| <b>226B3</b>         | <b>R.O.C. 50%</b>     | 582 kg   | 1284 lb | 571 kg   | 1260 lb | NR       | NR      | NR       | NR      |
|                      | <b>Dump Clearance</b> | 2106 mm  | 83 in   | 2106 mm  | 83 in   | NR       | NR      | NR       | NR      |
|                      | <b>Reach</b>          | 613 mm   | 24 in   | 613 mm   | 24 in   | NR       | NR      | NR       | NR      |
| <b>242B3</b>         | <b>R.O.C. 50%</b>     | 891 kg   | 1965 lb | 880 kg   | 1940 lb | 871 kg   | 1920 lb | NR       | NR      |
|                      | <b>Dump Clearance</b> | 2362 mm  | 93 in   | 2362 mm  | 93 in   | 2362 mm  | 93 in   | NR       | NR      |
|                      | <b>Reach</b>          | 814 mm   | 32 in   | 814 mm   | 32 in   | 814 mm   | 32 in   | NR       | NR      |
| <b>236B3</b>         | <b>R.O.C. 50%</b>     | 779 kg   | 1717 lb | 769 kg   | 1695 lb | 760 kg   | 1676 lb | 754 kg   | 1662 lb |
|                      | <b>Dump Clearance</b> | 2330 mm  | 92 in   | 2330 mm  | 92 in   | 2330 mm  | 92 in   | 2330 mm  | 92 in   |
|                      | <b>Reach</b>          | 600 mm   | 24 in   | 600 mm   | 24 in   | 600 mm   | 24 in   | 600 mm   | 24 in   |
| <b>252B3</b>         | <b>R.O.C. 50%</b>     | NR       | NR      | 1116 kg  | 2460 lb | 1107 kg  | 2441 lb | 1104 kg  | 2434 lb |
|                      | <b>Dump Clearance</b> | NR       | NR      | 2419 mm  | 95 in   | 2419 mm  | 95 in   | 2419 mm  | 95 in   |
|                      | <b>Reach</b>          | NR       | NR      | 860 mm   | 34 in   | 860 mm   | 34 in   | 860 mm   | 34 in   |
| <b>247B3</b>         | <b>R.O.C. 35%</b>     | 600 kg   | 1322 lb | 592 kg   | 1306 lb | 586 kg   | 1292 lb | 583 kg   | 1285 lb |
|                      | <b>Dump Clearance</b> | 1922 mm  | 76 in   | 1922 mm  | 76 in   | 1922 mm  | 76 in   | 1922 mm  | 76 in   |
|                      | <b>Reach</b>          | 752 mm   | 30 in   | 752 mm   | 30 in   | 752 mm   | 30 in   | 752 mm   | 30 in   |
| <b>257B3</b>         | <b>R.O.C. 35%</b>     | 791 kg   | 1678 lb | 754 kg   | 1662 lb | 747 kg   | 1648 lb | 745 kg   | 1642 lb |
|                      | <b>Dump Clearance</b> | 2260 mm  | 89 in   | 2260 mm  | 89 in   | 2260 mm  | 89 in   | 2260 mm  | 89 in   |
|                      | <b>Reach</b>          | 792 mm   | 31 in   | 792 mm   | 31 in   | 792 mm   | 31 in   | 792 mm   | 31 in   |
| <b>259B3</b>         | <b>R.O.C. 35%</b>     | 844 kg   | 1861 lb | 837 kg   | 1844 lb | 830 kg   | 1831 lb | 828 kg   | 1826 lb |
|                      | <b>Dump Clearance</b> | 2236 mm  | 88 in   | 2236 mm  | 88 in   | 2236 mm  | 88 in   | 2236 mm  | 88 in   |
|                      | <b>Reach</b>          | 742 mm   | 29 in   | 742 mm   | 29 in   | 742 mm   | 29 in   | 742 mm   | 29 in   |

Table 5

| Multipurpose Buckets with Bolt On Edge and Debris Guard |               |          |        |          |        |          |        |          |        |
|---|---------------|----------|--------|----------|--------|----------|--------|----------|--------|
|   | P/N           | 325-7040 |        | 325-7050 |        | 325-7060 |        | 325-7070 |        |
|   | <b>Weight</b> | 374 kg   | 824 lb | 397 kg   | 876 lb | 421 kg   | 928 lb | 444 kg   | 979 lb |

(continued)

Product Information Section  
Rated Load

(Table 5, contd)

| <b>Multipurpose Buckets with Bolt On Edge and Debris Guard</b> |                       |         |         |         |         |         |         |         |         |
|--|-----------------------|---------|---------|---------|---------|---------|---------|---------|---------|
| <b>Models</b>  | <b>Bucket</b>         | 1524 mm | 60 in   | 1676 mm | 66 in   | 1829 mm | 72 in   | 1981 mm | 78 in   |
| <b>216B3</b>   | <b>R.O.C. 50%</b>     | 518 kg  | 1141 lb | 505 kg  | 1114 lb | NR      | NR      | NR      | NR      |
|  | <b>Dump Clearance</b> | 2110 mm | 83 in   | 2110 mm | 83 in   | NR      | NR      | NR      | NR      |
|  | <b>Reach</b>          | 623 mm  | 25 in   | 623 mm  | 25 in   | NR      | NR      | NR      | NR      |
| <b>226B3</b>   | <b>R.O.C. 50%</b>     | 556 kg  | 1225 lb | 543 kg  | 1198 lb | NR      | NR      | NR      | NR      |
|  | <b>Dump Clearance</b> | 2110 mm | 83 in   | 2110 mm | 83 in   | NR      | NR      | NR      | NR      |
|  | <b>Reach</b>          | 623 mm  | 25 in   | 623 mm  | 25 in   | NR      | NR      | NR      | NR      |
| <b>242B3</b>   | <b>R.O.C. 50%</b>     | 857 kg  | 1890 lb | 845 kg  | 1863 lb | 832 kg  | 1834 lb | NR      | NR      |
|  | <b>Dump Clearance</b> | 2235 mm | 88 in   | 2235 mm | 88 in   | 2235 mm | 88 in   | NR      | NR      |
|  | <b>Reach</b>          | 677 mm  | 27 in   | 677 mm  | 27 in   | 677 mm  | 27 in   | NR      | NR      |
| <b>236B3</b>   | <b>R.O.C. 50%</b>     | 748 kg  | 1649 lb | 736 kg  | 1621 lb | 723 kg  | 1593 lb | 714 kg  | 1574 lb |
|  | <b>Dump Clearance</b> | 2338 mm | 92 in   | 2338 mm | 92 in   | 2338 mm | 92 in   | 2338 mm | 92 in   |
|  | <b>Reach</b>          | 612 mm  | 24 in   | 612 mm  | 24 in   | 612 mm  | 24 in   | 612 mm  | 24 in   |
| <b>252B3</b>   | <b>R.O.C. 50%</b>     | NR      | NR      | 1076 kg | 2371 lb | 1062 kg | 2342 lb | 1056 kg | 2327 lb |
|  | <b>Dump Clearance</b> | NR      | NR      | 2475 mm | 97 in   | 2475 mm | 97 in   | 2475 mm | 97 in   |
|  | <b>Reach</b>          | NR      | NR      | 942 mm  | 37 in   | 942 mm  | 37 in   | 942 mm  | 37 in   |
| <b>247B3</b>   | <b>R.O.C. 35%</b>     | 578 kg  | 1274 lb | 569 kg  | 1256 lb | 561 kg  | 1236 lb | 555 kg  | 1224 lb |
|  | <b>Dump Clearance</b> | 2128 mm | 84 in   | 2128 mm | 84 in   | 2128 mm | 84 in   | 2128 mm | 84 in   |
|  | <b>Reach</b>          | 664 mm  | 26 in   | 664 mm  | 26 in   | 664 mm  | 26 in   | 664 mm  | 26 in   |
| <b>257B3</b>   | <b>R.O.C. 35%</b>     | 736 kg  | 1623 lb | 728 kg  | 1605 lb | 719 kg  | 1585 lb | 714 kg  | 1574 lb |
|  | <b>Dump Clearance</b> | 2231 mm | 88 in   | 2231 mm | 88 in   | 2231 mm | 88 in   | 2231 mm | 88 in   |
|  | <b>Reach</b>          | 801 mm  | 32 in   | 801 mm  | 32 in   | 801 mm  | 32 in   | 801 mm  | 32 in   |
| <b>259B3</b>   | <b>R.O.C. 35%</b>     | 818 kg  | 1804 lb | 810 kg  | 1786 lb | 801 kg  | 1766 lb | 796 kg  | 1756 lb |
|  | <b>Dump Clearance</b> | 2239 mm | 88 in   | 2239 mm | 88 in   | 2239 mm | 88 in   | 2239 mm | 88 in   |
|  | <b>Reach</b>          | 745 mm  | 29 in   | 745 mm  | 29 in   | 745 mm  | 29 in   | 745 mm  | 29 in   |

Table 6

| <b>Dirt Buckets with Bolt On Edge</b> |                   |                 |         |                 |         |                 |         |                 |        |
|---------------------------------------|-------------------|-----------------|---------|-----------------|---------|-----------------|---------|-----------------|--------|
|                                       | <b>P/N</b>        | <b>152-0230</b> |         | <b>152-0231</b> |         | <b>152-0232</b> |         | <b>188-2719</b> |        |
|                                       | <b>Weight</b>     | 176 kg          | 389 lb  | 171 kg          | 377 lb  | 199 kg          | 438 lb  | 247 kg          | 545 lb |
| <b>Models</b>                         | <b>Bucket</b>     | 1371 mm         | 54 in   | 1524 mm         | 60 in   | 1676 mm         | 66 in   | 1829 mm         | 72 in  |
| <b>216B3</b>                          | <b>R.O.C. 50%</b> | 648 kg          | 1428 lb | 635 kg          | 1399 lb | 621 kg          | 1369 lb | NR              | NR     |

(continued)

(Table 6, contd)

| <b>Dirt Buckets with Bolt On Edge</b> |                       |         |         |         |         |         |         |         |         |
|---------------------------------------|-----------------------|---------|---------|---------|---------|---------|---------|---------|---------|
|                                       | <b>Dump Clearance</b> | 2148 mm | 85 in   | 2148 mm | 85 in   | 2148 mm | 85 in   | NR      | NR      |
|                                       | <b>Reach</b>          | 569 mm  | 22 in   | 569 mm  | 22 in   | 569 mm  | 22 in   | NR      | NR      |
| <b>226B3</b>                          | <b>R.O.C. 50%</b>     | 688 kg  | 1516 lb | 674 kg  | 1487 lb | 660 kg  | 1456 lb | NR      | NR      |
|                                       | <b>Dump Clearance</b> | 2148 mm | 85 in   | 2148 mm | 85 in   | 2148 mm | 85 in   | NR      | NR      |
|                                       | <b>Reach</b>          | 569 mm  | 22 in   | 569 mm  | 22 in   | 569 mm  | 22 in   | NR      | NR      |
| <b>242B3</b>                          | <b>R.O.C. 50%</b>     | 1006 kg | 2217 lb | 992 kg  | 2187 lb | 978 kg  | 2156 lb | 972 kg  | 2144 lb |
|                                       | <b>Dump Clearance</b> | 2302 mm | 91 in   | 2302 mm | 91 in   | 2302 mm | 91 in   | 2302 mm | 91 in   |
|                                       | <b>Reach</b>          | 628 mm  | 25 in   | 628 mm  | 25 in   | 628 mm  | 25 in   | 628 mm  | 25 in   |
| <b>236B3</b>                          | <b>R.O.C. 50%</b>     | NR      | NR      | 903 kg  | 1991 lb | 892 kg  | 1967 lb | 885 kg  | 1951 lb |
|                                       | <b>Dump Clearance</b> | NR      | NR      | 2377 mm | 94 in   | 2374 mm | 93 in   | 2374 mm | 93 in   |
|                                       | <b>Reach</b>          | NR      | NR      | 555 mm  | 22 in   | 558 mm  | 22 in   | 558 mm  | 22 in   |
| <b>252B3</b>                          | <b>R.O.C. 50%</b>     | NR      | NR      | NR      | NR      | 1254 kg | 2765 lb | 1248 kg | 2751 lb |
|                                       | <b>Dump Clearance</b> | NR      | NR      | NR      | NR      | 2314 mm | 91 in   | 2314 mm | 91 in   |
|                                       | <b>Reach</b>          | NR      | NR      | NR      | NR      | 729 mm  | 29 in   | 729 mm  | 29 in   |
| <b>247B3</b>                          | <b>R.O.C. 35%</b>     | NR      | NR      | 669 kg  | 1475 lb | 659 kg  | 1454 lb | 656 kg  | 1445 lb |
|                                       | <b>Dump Clearance</b> | NR      | NR      | 1973 mm | 78 in   | 1973 mm | 78 in   | 1973 mm | 78 in   |
|                                       | <b>Reach</b>          | NR      | NR      | 693 mm  | 27 in   | 693 mm  | 27 in   | 693 mm  | 27 in   |
| <b>257B3</b>                          | <b>R.O.C. 35%</b>     | NR      | NR      | 835 kg  | 1824 lb | 826 kg  | 1820 lb | 822 kg  | 1812 lb |
|                                       | <b>Dump Clearance</b> | NR      | NR      | 2277 mm | 90 in   | 2277 mm | 90 in   | 2277 mm | 90 in   |
|                                       | <b>Reach</b>          | NR      | NR      | 764 mm  | 30 in   | 764 mm  | 30 in   | 764 mm  | 30 in   |
| <b>259B3</b>                          | <b>R.O.C. 35%</b>     | NR      | NR      | 920 kg  | 2029 lb | 911 kg  | 2008 lb | 907 kg  | 2000 lb |
|                                       | <b>Dump Clearance</b> | NR      | NR      | 2254 mm | 89 in   | 2254 mm | 89 in   | 2254 mm | 89 in   |
|                                       | <b>Reach</b>          | NR      | NR      | 714 mm  | 28 in   | 714 mm  | 28 in   | 714 mm  | 28 in   |

Table 7

| <b>Utility Buckets</b> |                       |                 |         |                 |         |                 |        |
|------------------------|-----------------------|-----------------|---------|-----------------|---------|-----------------|--------|
|                        | <b>P/N</b>            | <b>285-6096</b> |         | <b>285-6099</b> |         | <b>285-6102</b> |        |
|                        | <b>Weight</b>         | 211 kg          | 465 lb  | 226 kg          | 498 lb  | 240 kg          | 529 lb |
| <b>Models</b>          | <b>Bucket</b>         | 1524 mm         | 60 in   | 1676 mm         | 66 in   | 1829 mm         | 72 in  |
| <b>216B3</b>           | <b>R.O.C. 50%</b>     | 613 kg          | 1352 lb | 606 kg          | 1335 lb | NR              | NR     |
|                        | <b>Dump Clearance</b> | 2089 mm         | 82 in   | 2089 mm         | 82 in   | NR              | NR     |
|                        | <b>Reach</b>          | 644 mm          | 25 in   | 644 mm          | 25 in   | NR              | NR     |

(continued)

Product Information Section  
Rated Load

(Table 7, contd)

| Utility Buckets |                |         |         |         |         |         |         |
|-----------------|----------------|---------|---------|---------|---------|---------|---------|
| 226B3           | R.O.C. 50%     | 652 kg  | 1438 lb | 645 kg  | 1421 lb | NR      | NR      |
|                 | Dump Clearance | 2089 mm | 82 in   | 2089 mm | 82 in   | NR      | NR      |
|                 | Reach          | 644 mm  | 25 in   | 644 mm  | 25 in   | NR      | NR      |
| 242B3           | R.O.C. 50%     | 966 kg  | 2131 lb | 959 kg  | 2114 lb | 952 kg  | 2099 lb |
|                 | Dump Clearance | 2337 mm | 92 in   | 2337 mm | 92 in   | 2337 mm | 92 in   |
|                 | Reach          | 845 mm  | 33 in   | 845 mm  | 33 in   | 845 mm  | 33 in   |
| 236B3           | R.O.C. 50%     | 851 kg  | 1876 lb | 843 kg  | 1858 lb | 836 kg  | 1843 lb |
|                 | Dump Clearance | 2315 mm | 91 in   | 2312 mm | 91 in   | 2312 mm | 91 in   |
|                 | Reach          | 628 mm  | 25 in   | 630 mm  | 25 in   | 630 mm  | 25 in   |
| 252B3           | R.O.C. 50%     | NR      | NR      | 1197 kg | 2639 lb | 1191 kg | 2626 lb |
|                 | Dump Clearance | NR      | NR      | 2399 mm | 94 in   | 2399 mm | 94 in   |
|                 | Reach          | NR      | NR      | 889 mm  | 35 in   | 889 mm  | 35 in   |
| 247B3           | R.O.C. 35%     | 651 kg  | 1434 lb | 646 kg  | 1423 lb | 641 kg  | 1413 lb |
|                 | Dump Clearance | 1909 mm | 75 in   | 1909 mm | 75 in   | 1909 mm | 75 in   |
|                 | Reach          | 772 mm  | 30 in   | 772 mm  | 30 in   | 772 mm  | 30 in   |
| 257B3           | R.O.C. 35%     | 815 kg  | 1797 lb | 810 kg  | 1786 lb | 805 kg  | 1775 lb |
|                 | Dump Clearance | 2237 mm | 88 in   | 2237 mm | 88 in   | 2237 mm | 88 in   |
|                 | Reach          | 820 mm  | 32 in   | 820 mm  | 32 in   | 820 mm  | 32 in   |
| 259B3           | R.O.C. 35%     | 898 kg  | 1980 lb | 893 kg  | 1969 lb | 888 kg  | 1959 lb |
|                 | Dump Clearance | 2214 mm | 87 in   | 2214 mm | 87 in   | 2214 mm | 87 in   |
|                 | Reach          | 770 mm  | 30 in   | 770 mm  | 30 in   | 770 mm  | 30 in   |

Table 8

| Light Material Buckets |                |          |         |          |         |          |         |
|------------------------|----------------|----------|---------|----------|---------|----------|---------|
|                        | P/N            | 279-5421 |         | 279-5424 |         | 279-5429 |         |
|                        | Weight         | 266 kg   | 587 lb  | 280 kg   | 618 lb  | 338 kg   | 744 lb  |
| Models                 | Bucket         | 1829 mm  | 72 in   | 1981 mm  | 78 in   | 2134 mm  | 84 in   |
| 216B3                  | R.O.C. 50%     | 626 kg   | 1379 lb | NR       | NR      | NR       | NR      |
|                        | Dump Clearance | 2063 mm  | 81 in   | NR       | NR      | NR       | NR      |
|                        | Reach          | 677 mm   | 27 in   | NR       | NR      | NR       | NR      |
| 226B3                  | R.O.C. 50%     | 667 kg   | 1470 lb | NR       | NR      | NR       | NR      |
|                        | Dump Clearance | 2063 mm  | 81 in   | NR       | NR      | NR       | NR      |
|                        | Reach          | 677 mm   | 27 in   | NR       | NR      | NR       | NR      |
| 242B3                  | R.O.C. 50%     | 1001 kg  | 2207 lb | 993 kg   | 2190 lb | 986 kg   | 2173 lb |
|                        | Dump Clearance | 2311 mm  | 91 in   | 2311 mm  | 91 in   | 2311 mm  | 91 in   |

(continued)

(Table 8, contd)

| <b>Light Material Buckets</b> |                       |         |         |         |         |         |         |
|-------------------------------|-----------------------|---------|---------|---------|---------|---------|---------|
|                               | <b>Reach</b>          | 876 mm  | 34 in   | 876 mm  | 34 in   | 876 mm  | 34 in   |
| <b>236B3</b>                  | <b>R.O.C. 50%</b>     | 881 kg  | 1942 lb | 873 kg  | 1925 lb | 866 kg  | 1909 lb |
|                               | <b>Dump Clearance</b> | 2285 mm | 90 in   | 2285 mm | 90 in   | 2285 mm | 90 in   |
|                               | <b>Reach</b>          | 662 mm  | 26 in   | 662 mm  | 26 in   | 662 mm  | 26 in   |
| <b>252B3</b>                  | <b>R.O.C. 50%</b>     | 1258 kg | 2773 lb | 1250 kg | 2756 lb | 1243 kg | 2740 lb |
|                               | <b>Dump Clearance</b> | 2369 mm | 93 in   | 2369 mm | 93 in   | 2369 mm | 93 in   |
|                               | <b>Reach</b>          | 919 mm  | 36 in   | 919 mm  | 36 in   | 919 mm  | 36 in   |
| <b>247B3</b>                  | <b>R.O.C. 35%</b>     | 672 kg  | 1481 lb | 666 kg  | 1469 lb | 661 kg  | 1458 lb |
|                               | <b>Dump Clearance</b> | 1880 mm | 74 in   | 1880 mm | 74 in   | 1880 mm | 74 in   |
|                               | <b>Reach</b>          | 809 mm  | 32 in   | 809 mm  | 32 in   | 809 mm  | 32 in   |
| <b>257B3</b>                  | <b>R.O.C. 35%</b>     | 844 kg  | 1860 lb | 838 kg  | 1848 lb | 833 kg  | 1837 lb |
|                               | <b>Dump Clearance</b> | 2201 mm | 87 in   | 2201 mm | 87 in   | 2201 mm | 87 in   |
|                               | <b>Reach</b>          | 845 mm  | 33 in   | 845 mm  | 33 in   | 845 mm  | 33 in   |
| <b>259B3</b>                  | <b>R.O.C. 35%</b>     | 927 kg  | 2044 lb | 922 kg  | 2032 lb | 917 kg  | 2021 lb |
|                               | <b>Dump Clearance</b> | 2178 mm | 86 in   | 2178 mm | 86 in   | 2178 mm | 86 in   |
|                               | <b>Reach</b>          | 795 mm  | 31 in   | 795 mm  | 31 in   | 795 mm  | 31 in   |

Table 9

| <b>Industrial Grapple Buckets <sup>(1)</sup></b> |                       |                 |         |                 |         |                 |         |
|--|-----------------------|-----------------|---------|-----------------|---------|-----------------|---------|
|  | <b>P/N</b>            | <b>157-7223</b> |         | <b>157-7224</b> |         | <b>157-7225</b> |         |
|  | <b>Weight</b>         | 409 kg          | 902 lb  | 425 kg          | 937 lb  | 440 kg          | 970 lb  |
| <b>Models</b>                                    | <b>Bucket</b>         | 1524 mm         | 60 in   | 1676 mm         | 66 in   | 1829 mm         | 72 in   |
| <b>216B3</b>                                     | <b>R.O.C. 50%</b>     | 553 kg          | 1219 lb | 545 kg          | 1202 lb | NR              | NR      |
|  | <b>Dump Clearance</b> | 2114 mm         | 83 in   | 2114 mm         | 83 in   | NR              | NR      |
|  | <b>Reach</b>          | 612 mm          | 24 in   | 612 mm          | 24 in   | NR              | NR      |
| <b>226B3</b>                                     | <b>R.O.C. 50%</b>     | 594 kg          | 1308 lb | 586 kg          | 1291 lb | NR              | NR      |
|  | <b>Dump Clearance</b> | 2114 mm         | 83 in   | 2114 mm         | 83 in   | NR              | NR      |
|  | <b>Reach</b>          | 612 mm          | 24 in   | 612 mm          | 24 in   | NR              | NR      |
| <b>242B3</b>                                     | <b>R.O.C. 50%</b>     | 923 kg          | 2035 lb | 915 kg          | 2018 lb | 908 kg          | 2002 lb |
|  | <b>Dump Clearance</b> | 2362 mm         | 93 in   | 2362 mm         | 93 in   | 2362 mm         | 93 in   |
|  | <b>Reach</b>          | 814 mm          | 32 in   | 814 mm          | 32 in   | 814 mm          | 32 in   |
| <b>236B3</b>                                     | <b>R.O.C. 50%</b>     | 800 kg          | 1764 lb | 792 kg          | 1746 lb | 784 kg          | 1728 lb |
|  | <b>Dump Clearance</b> | 2338 mm         | 92 in   | 2338 mm         | 92 in   | 2338 mm         | 92 in   |
|  | <b>Reach</b>          | 599 mm          | 24 in   | 599 mm          | 24 in   | 599 mm          | 24 in   |

(continued)

Product Information Section  
Rated Load

(Table 9, contd)

| Industrial Grapple Buckets <sup>(1)</sup> |                |         |         |         |         |         |         |
|---|----------------|---------|---------|---------|---------|---------|---------|
| 252B3                                     | R.O.C. 50%     | NR      | NR      | 1164 kg | 2566 lb | 1157 kg | 2551 lb |
|   | Dump Clearance | NR      | NR      | 2427 mm | 96 in   | 2427 mm | 96 in   |
|   | Reach          | NR      | NR      | 861 mm  | 34 in   | 861 mm  | 34 in   |
| 247B3                                     | R.O.C. 35%     | 620 kg  | 24 in   | 615 kg  | 1356 lb | 610 kg  | 1345 lb |
|   | Dump Clearance | 1924 mm | 76 in   | 1924 mm | 76 in   | 1924 mm | 76 in   |
|   | Reach          | 760 mm  | 30 in   | 760 mm  | 30 in   | 760 mm  | 30 in   |
| 257B3                                     | R.O.C. 35%     | 790 kg  | 1742 lb | 785 kg  | 1730 lb | 780 kg  | 1719 lb |
|   | Dump Clearance | 2268 mm | 89 in   | 2268 mm | 89 in   | 2268 mm | 89 in   |
|   | Reach          | 793 mm  | 31 in   | 793 mm  | 31 in   | 793 mm  | 31 in   |
| 259B3                                     | R.O.C. 35%     | 875 kg  | 1930 lb | 870 kg  | 1919 lb | 865 kg  | 1908 lb |
|   | Dump Clearance | 2244 mm | 88 in   | 2244 mm | 88 in   | 2244 mm | 88 in   |
|   | Reach          | 743 mm  | 29 in   | 743 mm  | 29 in   | 743 mm  | 29 in   |

<sup>(1)</sup> The rated capacity is calculated with a full bucket of dirt. Grasping objects with the grapple will lower the rated capacity.

Table 10

| Utility Grapple Buckets <sup>(1)</sup> |                |          |         |          |         |
|--|----------------|----------|---------|----------|---------|
|  | P/N            | 285-6111 |         | 285-6110 |         |
|  | Weight         | 363 kg   | 800 lb  | 379 kg   | 835 lb  |
| Models                                 | Bucket         | 1676 mm  | 66 in   | 1829 mm  | 72 in   |
| 216B3                                  | R.O.C. 50%     | 533 kg   | 1175 lb | NR       | NR      |
|  | Dump Clearance | 2089 mm  | 82 in   | NR       | NR      |
|  | Reach          | 644 mm   | 25 in   | NR       | NR      |
| 226B3                                  | R.O.C. 50%     | 572 kg   | 1261 lb | NR       | NR      |
|  | Dump Clearance | 2089 mm  | 82 in   | NR       | NR      |
|  | Reach          | 644 mm   | 25 in   | NR       | NR      |
| 242B3                                  | R.O.C. 50%     | 885 kg   | 1950 lb | 877 kg   | 1933 lb |
|  | Dump Clearance | 2311 mm  | 91 in   | 2311 mm  | 91 in   |
|  | Reach          | 856 mm   | 34 in   | 856 mm   | 34 in   |
| 236B3                                  | R.O.C. 50%     | 796 kg   | 1755 lb | 789 kg   | 1739 lb |
|  | Dump Clearance | 2312 mm  | 91 in   | 2312 mm  | 91 in   |
|  | Reach          | 630 mm   | 25 in   | 630 mm   | 25 in   |
| 252B3                                  | R.O.C. 50%     | 1151 kg  | 2538 lb | 1144 kg  | 2522 lb |
|  | Dump Clearance | 2399 mm  | 94 in   | 2399 mm  | 94 in   |
|  | Reach          | 889 mm   | 35 in   | 889 mm   | 35 in   |
| 247B3                                  | R.O.C. 35%     | 594 kg   | 1310 lb | 589 kg   | 1298 lb |
|  | Dump Clearance | 1903 mm  | 75 in   | 1903 mm  | 75 in   |
|  | Reach          | 783 mm   | 31 in   | 783 mm   | 31 in   |

(continued)

(Table 10, contd)

| Utility Grapple Buckets <sup>(1)</sup> |                |         |         |         |         |
|--|----------------|---------|---------|---------|---------|
| 257B3                                  | R.O.C. 35%     | 757 kg  | 1670 lb | 752 kg  | 1658 lb |
|  | Dump Clearance | 2205 mm | 87 in   | 2205 mm | 87 in   |
|  | Reach          | 825 mm  | 32 in   | 825 mm  | 32 in   |
| 259B3                                  | R.O.C. 35%     | 840 kg  | 1852 lb | 834 kg  | 1840 lb |
|  | Dump Clearance | 2182 mm | 86 in   | 2182 mm | 86 in   |
|  | Reach          | 776 mm  | 31 in   | 776 mm  | 31 in   |

(1) The rated capacity is calculated with a full bucket of dirt. Grasping objects with the grapple will lower the rated capacity.

### Rated Loads for Forks

#### **⚠ WARNING**

Failure to comply to the rated load can cause possible personal injury or property damage. Review the rated load of a particular work tool before performing any operation. Make adjustments to the rated load as necessary for non-standard configurations.

The rated operating load is defined by “SAE J1197-2002”, “EN 474-3:2006” and “ISO 14397-1:2007”. The rated operating load is the least amount of weight of the following conditions:

- 35% of the full static tipping load on a surface that is soft or a surface that is uneven (applies to track machines only)
- 50% of the full static tipping load on a surface that is hard, smooth and level
- 100% of the lifting capacity

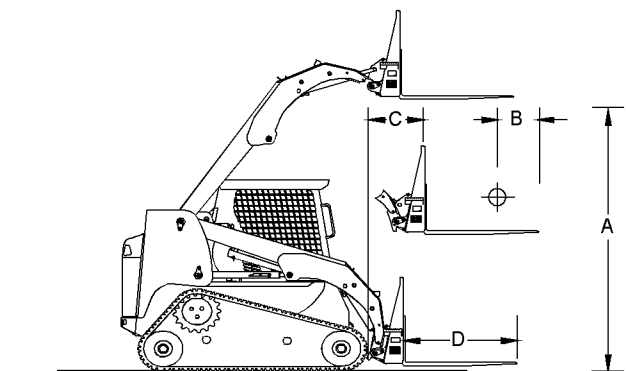

Illustration 49

g02125251

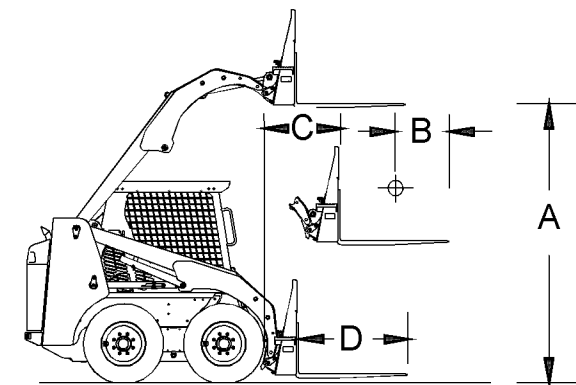

Illustration 50

g02141860

Dimension (A) represents the maximum fork height.  
Dimension (B) represents the load center.  
Dimension (C) represents the reach.  
Dimension (D) represents the fork tine length.

The following tables provide the rated operating capacity (R.O.C.) for the standard machine that is equipped with the following:

- Full fuel tank and lubricants
- 75 kg (165 lb) operator

Product Information Section  
Rated Load

- Cat bucket
- 10x16.5 tires on the following machines: 216B3 and 226B3
- 12x16.5 tires on the following machines: 236B3, 242B3 and 252B3

Table 11

| Pallet Fork   |                           |          |         |          |         |          |         |
|---------------|---------------------------|----------|---------|----------|---------|----------|---------|
|               | P/N                       | 353-1694 |         | 353-1696 |         | 353-1697 |         |
|               | <b>Weight</b>             | 175 kg   | 386 lb  | 186 kg   | 409 lb  | 195 kg   | 430 lb  |
| <b>Models</b> | <b>Fork</b>               | 914 mm   | 36 in   | 1067 mm  | 42 in   | 1219 mm  | 48 in   |
|               | <b>Load Center</b>        | 455 mm   | 18 in   | 535 mm   | 21 in   | 610 mm   | 24 in   |
| <b>216B3</b>  | <b>R.O.C. 50%</b>         | 490 kg   | 1079 lb | 461 kg   | 1017 lb | 436 kg   | 962 lb  |
|               | <b>Max Height of Fork</b> | 2722 mm  | 107 in  | 2722 mm  | 107 in  | 2699 mm  | 106 in  |
|               | <b>Reach</b>              | 740 mm   | 29 in   | 748 mm   | 29 in   | 747 mm   | 29 in   |
| <b>226B3</b>  | <b>R.O.C. 50%</b>         | 520 kg   | 1147 lb | 490 kg   | 1081 lb | 464 kg   | 1024 lb |
|               | <b>Max Height of Fork</b> | 2767 mm  | 109 in  | 2718 mm  | 107 in  | 2718 mm  | 107 in  |
|               | <b>Reach</b>              | 742 mm   | 29 in   | 746 mm   | 29 in   | 745 mm   | 29 in   |
| <b>242B3</b>  | <b>R.O.C. 50%</b>         | 759 kg   | 1674 lb | 718 kg   | 1583 lb | 682 kg   | 1504 lb |
|               | <b>Max Height of Fork</b> | 2955 mm  | 116 in  | 2955 mm  | 116 in  | 2946 mm  | 116 in  |
|               | <b>Reach</b>              | 668 mm   | 26 in   | 676 mm   | 27 in   | 675 mm   | 27 in   |
| <b>236B3</b>  | <b>R.O.C. 50%</b>         | 677 kg   | 1493 lb | 642 kg   | 1415 lb | 611 kg   | 1346 lb |
|               | <b>Max Height of Fork</b> | 2986 mm  | 118 in  | 2978 mm  | 117 in  | 2978 mm  | 117 in  |
|               | <b>Reach</b>              | 800 mm   | 31 in   | 809 mm   | 32 in   | 807 mm   | 32 in   |
| <b>252B3</b>  | <b>R.O.C. 50%</b>         | 942 kg   | 2076 lb | 893 kg   | 1969 lb | 851 kg   | 1875 lb |
|               | <b>Max Height of Fork</b> | 3120 mm  | 123 in  | 3120 mm  | 123 in  | 3112 mm  | 123 in  |
|               | <b>Reach</b>              | 710 mm   | 28 in   | 718 mm   | 28 in   | 716 mm   | 28 in   |
| <b>247B3</b>  | <b>R.O.C. 35%</b>         | 523 kg   | 1153 lb | 494 kg   | 1088 lb | 468 kg   | 1033 lb |
|               | <b>Max Height of Fork</b> | 2718 mm  | 107 in  | 2712 mm  | 107 in  | 2707 mm  | 107 in  |
|               | <b>Reach</b>              | 793 mm   | 31 in   | 800 mm   | 32 in   | 798 mm   | 31 in   |
| <b>257B3</b>  | <b>R.O.C. 35%</b>         | 652 kg   | 1437 lb | 617 kg   | 1360 lb | 587 kg   | 1294 lb |
|               | <b>Max Height of Fork</b> | 2919 mm  | 115 in  | 2913 mm  | 115 in  | 2908 mm  | 114 in  |
|               | <b>Reach</b>              | 788 mm   | 31 in   | 796 mm   | 31 in   | 793 mm   | 31 in   |
| <b>259B3</b>  | <b>R.O.C. 35%</b>         | 729 kg   | 1607 lb | 690 kg   | 1522 lb | 657 kg   | 1449 lb |
|               | <b>Max Height of Fork</b> | 2896 mm  | 114 in  | 2890 mm  | 114 in  | 2885 mm  | 114 in  |
|               | <b>Reach</b>              | 1652 mm  | 65 in   | 1812 mm  | 71 in   | 1962 mm  | 77 in   |

Table 12

| Utility Fork |             |          |         |          |         |
|--------------|-------------|----------|---------|----------|---------|
|              | P/N         | 285-6105 |         | 285-6110 |         |
|              | Weight      | 198 kg   | 436 lb  | 219 kg   | 484 lb  |
| Models       | Fork        | 1676 mm  | 66 in   | 1829 mm  | 72 in   |
|              | Load Center | 314 mm   | 12 in   | NR       | NR      |
| 216B3        | R.O.C. 50%  | 519 kg   | 1145 lb | NR       | NR      |
| 226B3        | R.O.C. 50%  | 552 kg   | 1218 lb | NR       | NR      |
| 242B3        | R.O.C. 50%  | 813 kg   | 1792 lb | 805 kg   | 1775 lb |
| 236B3        | R.O.C. 50%  | 723 kg   | 1594 lb | 715 kg   | 1576 lb |
| 252B3        | R.O.C. 50%  | 1013 kg  | 2233 lb | 1005 kg  | 2216 lb |
| 247B3        | R.O.C. 35%  | 637 kg   | 1405 lb | 632 kg   | 1392 lb |
| 257B3        | R.O.C. 35%  | 692 kg   | 1525 lb | 686 kg   | 1513 lb |
| 259B3        | R.O.C. 35%  | 768 kg   | 1692 lb | 762 kg   | 1681 lb |

Table 13

| Utility Grapple Fork |             |          |         |          |         |
|----------------------|-------------|----------|---------|----------|---------|
|                      | P/N         | 285-6114 |         | 285-6115 |         |
|                      | Weight      | 304 kg   | 671 lb  | 326 kg   | 718 lb  |
| Models               | Fork        | 1676 mm  | 66 in   | 1829 mm  | 72 in   |
|                      | Load Center | 314 mm   | 12 in   | NR       | NR      |
| 216B3                | R.O.C. 50%  | 469 kg   | 1035 lb | NR       | NR      |
| 226B3                | R.O.C. 50%  | 503 kg   | 1108 lb | NR       | NR      |
| 242B3                | R.O.C. 50%  | 764 kg   | 1684 lb | 755 kg   | 1664 lb |
| 236B3                | R.O.C. 50%  | 674 kg   | 1486 lb | 665 kg   | 1466 lb |
| 252B3                | R.O.C. 50%  | 965 kg   | 2127 lb | 956 kg   | 2108 lb |
| 247B3                | R.O.C. 35%  | 631 kg   | 1391 lb | 624 kg   | 1376 lb |
| 257B3                | R.O.C. 35%  | 657 kg   | 1449 lb | 651 kg   | 1435 lb |
| 259B3                | R.O.C. 35%  | 733 kg   | 1616 lb | 727 kg   | 1603 lb |

Table 14

| Industrial Grapple Fork |             |          |         |          |         |
|-------------------------|-------------|----------|---------|----------|---------|
|                         | P/N         | 279-5350 |         | 279-5360 |         |
|                         | Weight      | 502 kg   | 1106 lb | 548 kg   | 1208 lb |
| Models                  | Fork        | 1676 mm  | 66 in   | 1829 mm  | 72 in   |
|                         | Load Center | 280 mm   | 11 in   | NR       | NR      |
| 216B3                   | R.O.C. 50%  | 369 kg   | 814 lb  | NR       | NR      |
| 226B3                   | R.O.C. 50%  | 402 kg   | 886 lb  | NR       | NR      |

(continued)

(Table 14, contd)

| Industrial Grapple Fork |            |        |         |        |         |
|-------------------------|------------|--------|---------|--------|---------|
| 242B3                   | R.O.C. 50% | 660 kg | 1455 lb | 640 kg | 1411 lb |
| 236B3                   | R.O.C. 50% | 576 kg | 1270 lb | 555 kg | 1224 lb |
| 252B3                   | R.O.C. 50% | 863 kg | 1903 lb | 842 kg | 1856 lb |
| 247B3                   | R.O.C. 35% | 579 kg | 1277 lb | 565 kg | 1247 lb |
| 257B3                   | R.O.C. 35% | 583 kg | 1286 lb | 569 kg | 1255 lb |
| 259B3                   | R.O.C. 35% | 659 kg | 1452 lb | 645 kg | 1422 lb |

## Rated Load with a Material Handling Arm

### WARNING

Failure to comply to the rated load can cause possible personal injury or property damage. Review the rated load of a particular work tool before performing any operation. Make adjustments to the rated load as necessary for non-standard configurations.

The rated operating load is defined by “EN 474-3:2006” and “ISO 14397-1:2007”. The rated operating load is the least amount of weight of the following conditions:

- 35% of the full static tipping load on a surface that is soft or a surface that is uneven
- 50% of the full static tipping load on a surface that is hard, smooth and level
- 100% of the lifting capacity
- A working load limit of 907 kg (2000 lb)

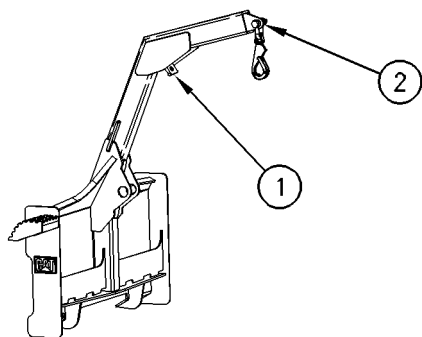

Illustration 51

g00668844

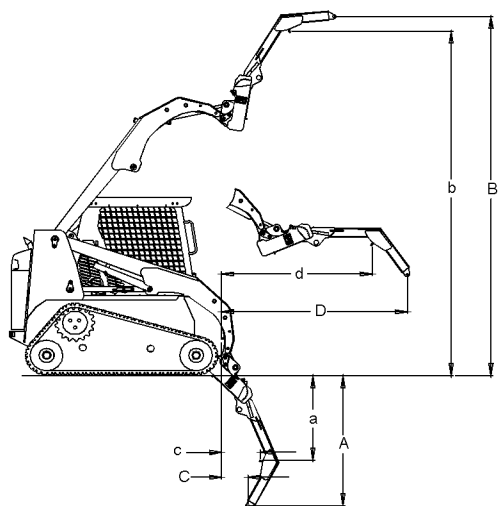

Illustration 52

g02125252

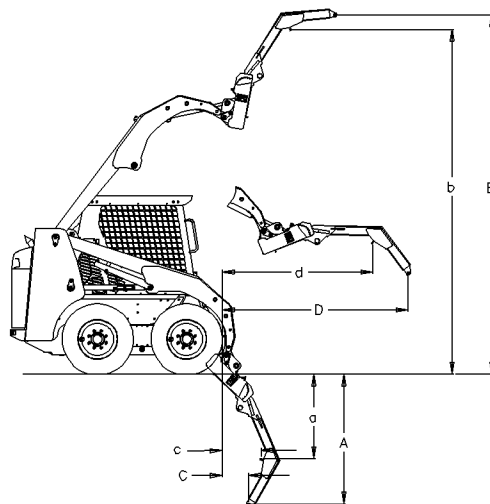

Illustration 53

g00656171

Dimension (A) represents the clearance at the full down position from Lifting Point 2.

Dimension (a) represents the clearance at the full down position from Lifting Point 1.

Dimension (B) represents the clearance at maximum height from Lifting Point 2.

Dimension (b) represents the clearance at maximum height from Lifting Point 1.

Dimension (C) represents the minimum reach from Lifting Point 2.

Dimension (c) represents the minimum reach from Lifting Point 1.

Dimension (D) represents the maximum reach from Lifting Point 2.

Dimension (d) represents the maximum reach from Lifting Point 1.

The following tables provide the rated operating capacity (R.O.C.) for the standard machine that is equipped with the following:

- Full fuel tank and lubricants
- 75 kg (165 lb) operator
- Cat bucket
- 10x16.5 tires on the following machines: 216B3 and 226B3
- 12x16.5 tires on the following machines: 236B3, 242B3 and 252B3

Product Information Section  
Rated Load

Table 15

| <b>Material Handling Arm</b> |                                    |                 |         |                |         |
|------------------------------|------------------------------------|-----------------|---------|----------------|---------|
|                              | <b>P/N</b>                         | <b>216-8756</b> |         |                |         |
|                              | <b>Weight</b>                      | 131 kg          |         | 289 lb         |         |
| <b>Models</b>                |                                    | <b>Point 1</b>  |         | <b>Point 2</b> |         |
| <b>216B3</b>                 | <b>R.O.C. 50%</b>                  | 387 kg          | 853 lb  | 320 kg         | 705 lb  |
|                              | <b>Clearance at Full Down</b>      | -950 mm         | -37 in  | -1336 mm       | -53 in  |
|                              | <b>Clearance at Maximum Height</b> | 4028 mm         | 159 in  | 4480 mm        | 176 in  |
|                              | <b>Minimum Reach</b>               | 418 mm          | 16 in   | 593 mm         | 23 in   |
|                              | <b>Maximum Reach</b>               | 1615 mm         | 64 in   | 2069 mm        | 81 in   |
| <b>226B3</b>                 | <b>R.O.C. 50%</b>                  | 411 kg          | 906 lb  | 340 kg         | 749 lb  |
|                              | <b>Clearance at Full Down</b>      | -950 mm         | -37 in  | -1336 mm       | -53 in  |
|                              | <b>Clearance at Maximum Height</b> | 4028 mm         | 159 in  | 4480 mm        | 176 in  |
|                              | <b>Minimum Reach</b>               | 418 mm          | 16 in   | 593 mm         | 23 in   |
|                              | <b>Maximum Reach</b>               | 1615 mm         | 64 in   | 2069 mm        | 81 in   |
| <b>242B3</b>                 | <b>R.O.C. 50%</b>                  | 594 kg          | 1310 lb | 491 kg         | 1083 lb |
|                              | <b>Clearance at Full Down</b>      | -911 mm         | -36 in  | -1397 mm       | -55 in  |
|                              | <b>Clearance at Maximum Height</b> | 4292 mm         | 169 in  | 4739 mm        | 187 in  |
|                              | <b>Minimum Reach</b>               | 511 mm          | 20 in   | 380 mm         | 15 in   |
|                              | <b>Maximum Reach</b>               | 1575 mm         | 62 in   | 2024 mm        | 80 in   |
| <b>236B3</b>                 | <b>R.O.C. 50%</b>                  | 543 kg          | 1197 lb | 451 kg         | 994 lb  |
|                              | <b>Clearance at Full Down</b>      | -964 mm         | -38 in  | -1196 mm       | -47 in  |
|                              | <b>Clearance at Maximum Height</b> | 4296 mm         | 169 in  | 4744 mm        | 187 in  |
|                              | <b>Minimum Reach</b>               | 456 mm          | 18 in   | 638 mm         | 25 in   |
|                              | <b>Maximum Reach</b>               | 1679 mm         | 66 in   | 2136 mm        | 84 in   |
| <b>252B3</b>                 | <b>R.O.C. 50%</b>                  | 749 kg          | 1651 lb | 607 kg         | 1338 lb |
|                              | <b>Clearance at Full Down</b>      | -985 mm         | -39 in  | -1474 mm       | -58 in  |
|                              | <b>Clearance at Maximum Height</b> | 4440 mm         | 175 in  | 4887 mm        | 192 in  |
|                              | <b>Minimum Reach</b>               | 483 mm          | 19 in   | 345 mm         | 14 in   |
|                              | <b>Maximum Reach</b>               | 1649 mm         | 65 in   | 2090 mm        | 82 in   |
| <b>247B3</b>                 | <b>R.O.C. 35%</b>                  | 403 kg          | 890 lb  | 332 kg         | 732 lb  |
|                              | <b>Clearance at Full Down</b>      | -1119 mm        | -44 in  | -1614 mm       | -64 in  |

(continued)

(Table 15, contd)

| Material Handling Arm |                             |         |         |          |         |
|-----------------------|-----------------------------|---------|---------|----------|---------|
|                       | Clearance at Maximum Height | 3868 mm | 152 in  | 4312 mm  | 170 in  |
|                       | Minimum Reach               | 653 mm  | 26 in   | 535 mm   | 21 in   |
|                       | Maximum Reach               | 1911 mm | 75 in   | 2350 mm  | 93 in   |
| 257B3                 | R.O.C. 35%                  | 505 kg  | 1114 lb | 417 kg   | 920 lb  |
|                       | Clearance at Full Down      | -934 mm | -37 in  | -1422 mm | -56 in  |
|                       | Clearance at Maximum Height | 4272 mm | 168 in  | 4717 mm  | 186 in  |
|                       | Minimum Reach               | 595 mm  | 23 in   | 407 mm   | 16 in   |
|                       | Maximum Reach               | 1703 mm | 67 in   | 2145 mm  | 84 in   |
| 259B3                 | R.O.C. 35%                  | 595 kg  | 1247 lb | 466 kg   | 1029 lb |
|                       | Clearance at Full Down      | -958 mm | -38 in  | -1448 mm | -57 in  |
|                       | Clearance at Maximum Height | 4257 mm | 168 in  | 4702 mm  | 185 in  |
|                       | Minimum Reach               | 545 mm  | 21 in   | 405 mm   | 16 in   |
|                       | Maximum Reach               | 1650 mm | 65 in   | 2102 mm  | 83 in   |

i07776946

## Specifications

**SMCS Code:** 7000

The specifications that are given herein describe the machine as the machine is manufactured by Caterpillar Inc. The machine is full of fluids. The machine is equipped with all options. The weight does not include the operator, work tools, or other attachments.

## Intended Use

This machine is classified as a Skid Steer Loader with wheels or tracks as described in "ISO 6165:2001". This machine normally has a front mounted bucket or another work tool for the principle intended functions of digging, loading, lifting, carrying, and moving material such as earth, crushed rock, or gravel. Additional work tools allow this machine to perform other specific tasks.

## Expected Life

The expected life, defined as total machine hours, of this machine is dependent upon many factors including the machine owner's desire to rebuild the machine back to factory specifications. The expected life interval of this machine is 8,000 service hours. The expected life interval corresponds to the service hours to engine overhaul or replacement. Service hours to engine overhaul or replacement may vary based on overall machine duty cycle. At the expected life interval, remove the machine from operation and consult your Cat dealer for inspect, repair, rebuild, install remanufactured, install new components, or disposal options and to establish a new expected life interval. If a decision is made to remove this machine from service, refer to Operation and Maintenance Manual, "Decommissioning and Disposal".

The following items are required to obtain an economical expected life of this machine:

- Perform regular preventive maintenance procedures as described in the Operation and Maintenance Manual.
- Perform machine inspections as described in the Operation and Maintenance Manual and correct any problems discovered.
- Perform system testing as described in the Operation and Maintenance Manual and correct any problems discovered.
- Ensure that machine application conditions comply with Caterpillar's recommendations.
- Ensure that the operating weight does not exceed limits set by manufacturer.
- Ensure that all frame cracks are identified, inspected, and repaired to prevent further development.

## Application/Configuration Restrictions

Refer to Operation and Maintenance Manual, "Machine Data" below for information about maximum machine weight.

Refer to Operation and Maintenance Manual, "Caterpillar Approved Work Tools" for information about acceptable work tools.

Lift arm height restrictions will be found in the Operation and Maintenance Manual for the appropriate work tool.

The maximum fore and aft slope for proper lubrication is 25 degrees continuous and 35 degrees for a duration of 15 minutes.

**Note:** Refer to the Operation and Maintenance Manual, "Identification Information" for the engine model number. Also, the engine model number is on the serial number plate on the engine.

This machine is approved for use in environments with no explosive gases.

## Machine Data

The specifications that are given herein describe the machine as the machine is manufactured by Caterpillar Inc. The machine is full of fluids. The machine is equipped with all options. The weight does not include the operator, work tools, or other attachments.

Table 16

| Sales Model | Maximum Machine Weight | Length  | Width   | Height  | Options Included in Maximum Machine Weight  |
|-------------|------------------------|---------|---------|---------|---|
| 216B3       | 2911 kg                | 2519 mm | 1525 mm | 1950 mm | Hydraulic coupler, self level, heavy-duty battery, ROPS C2 with heat and suspension seat, glass door, tool box, front/rear working lights, beacon, FOPS Level 2, 31x6x10 Flexport tires, and optional counterweights.                     |
|             | 6418 lb                | 99 in   | 60 in   | 77 in   |   |
| 226B3       | 2946 kg                | 2519 mm | 1525 mm | 1950 mm | Hydraulic coupler, High flow hydraulics, self level, heavy-duty battery, ROPS C3 with AC and suspension seat, glass door, tool box, front/rear working lights, beacon, FOPS Level 2, 31x6x10 Flexport tires, and optional counterweights. |
|             | 6495 lb                | 99 in   | 60 in   | 77 in   |   |
| 236B3       | 3639 kg                | 2800 mm | 1676 mm | 2092 mm | Hydraulic coupler, self level, ROPS C3 with AC and suspension seat, glass door, tool box, front/rear working lights, beacon, FOPS Level 2, 12x16.5 foam-filled tires, and optional counterweights.  |
|             | 8023 lb                | 110 in  | 66 in   | 82 in   |   |
| 242B3       | 3572 kg                | 2760 mm | 1676 mm | 2019 mm | Hydraulic coupler, High flow hydraulics, two speed, self level, ROPS C3 with AC and suspension seat, glass door, tool box, front/rear working lights, beacon, FOPS Level 2, 12x16.5 foam-filled tires, and optional counterweights.       |
|             | 7876 lb                | 109 in  | 66 in   | 79 in   |   |
| 247B3       | 3104 kg                | 2518 mm | 1676 mm | 1990 mm | Hydraulic coupler, self level, heavy-duty battery, ROPS C3 with AC and suspension seat, glass door, tool box, front/rear working lights, beacon, and FOPS Level 2.  |
|             | 6843 lb                | 99 in   | 66 in   | 78 in   |   |
| 252B3       | 3935 kg                | 2901 mm | 1829 mm | 2063 mm | Hydraulic coupler, self level, ROPS C3 with AC and suspension seat, glass door, tool box, front/rear working lights, beacon, FOPS Level 2, 12x16.5 foam-filled tires, and optional counterweights.  |
|             | 8675 lb                | 114 in  | 72 in   | 81 in   |   |
| 257B3       | 3634 kg                | 2718 mm | 1676 mm | 2035 mm | Hydraulic coupler, High flow hydraulics, two speed, self level, ROPS C3 with AC and suspension seat, glass door, tool box, front/rear working lights, beacon, FOPS Level 2, and optional counterweights.                                  |
|             | 8012 lb                | 107 in  | 66 in   | 80 in   |   |
| 259B3       | 4155 kg                | 2722 mm | 1676 mm | 1986 mm | 15.7" wide tracks, Hydraulic coupler, High flow hydraulics, self level, ROPS C3 with AC and suspension seat, glass door, tool box, front/rear working lights, beacon, FOPS Level 2, and optional counterweights.                          |
|             | 9160 lb                | 107 in  | 66 in   | 78 in   |   |

## Identification Information

i07776990

i06527350

### Plate Locations and Film Locations

**SMCS Code:** 1000; 7000

**S/N:** PWK1–Up

**S/N:** DXZ1–Up

The engine and chassis plate will be used to identify engine number, chassis number, and month, year of manufacturing.

For quick reference, record the identification numbers in the spaces that are provided below the illustration.

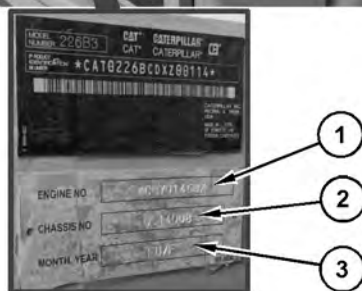

Illustration 54

g06009516

(1) Engine number \_\_\_\_\_

(2) Chassis number \_\_\_\_\_

(3) Month and Year of manufacture \_\_\_\_\_

### Plate Locations and Film Locations

**SMCS Code:** 1000; 7000

### Product Identification Number (PIN)

The Product Identification Number (PIN) will be used to identify a powered machine that is designed for an operator to ride.

Cat products such as engines, transmissions, and motorized work tools that are not designed for an operator to ride are identified by Serial Numbers.

For quick reference, record the identification numbers in the spaces that are provided below the illustration.

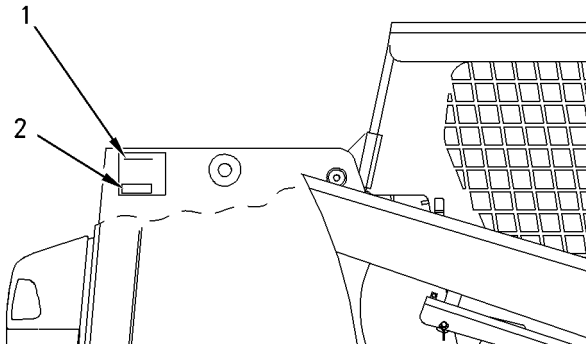

Illustration 55

g00902931

Month and Year of Manufacture Plate (If Required) (E) \_\_\_\_\_

CE Plate (If Required) (F) \_\_\_\_\_

Address of Manufacturer (G) \_\_\_\_\_

Issue (H) \_\_\_\_\_

Country of Origin Info Plate (If Required) (I) \_\_\_\_\_

Local regulation may require documentation of the month and/or year of manufacture in the Operation and Maintenance Manual. Enter on line (E) above if required.

The engine serial number plate is on the engine.

- Engine Serial Number \_\_\_\_\_

### CE Plate

**Note:** The CE plate is on machines that are going into the European Union.

**Note:** The CE plate is on machines that are certified to the European Union requirements that were effective at that time.

If the machine is equipped with the plate for the European Union, this plate will be attached to the PIN plate. Several pieces of information are stamped onto the "CE" plate.

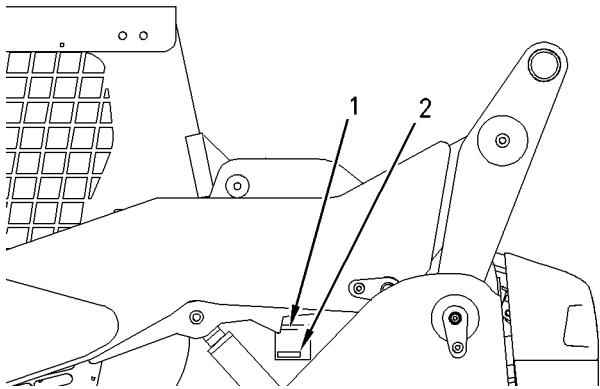

Illustration 56

g00902975

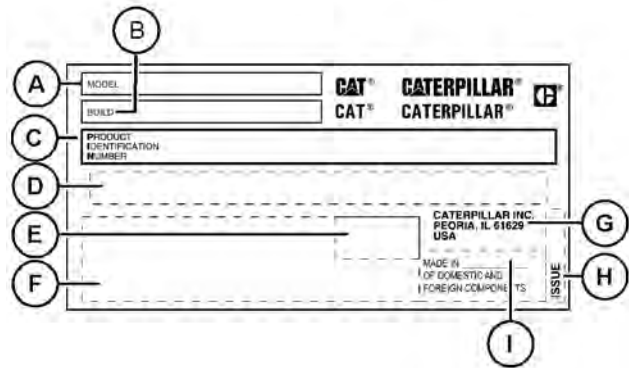

Illustration 57

g06201159

Manufacturer Name and Address \_\_\_\_\_

Model (A) \_\_\_\_\_

Build (B) \_\_\_\_\_

Product Identification Number (C) \_\_\_\_\_

Bar Code (D) \_\_\_\_\_

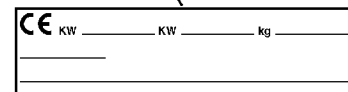
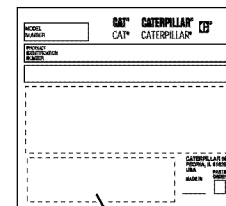

Illustration 58

g01883459

For machines that are compliant to "2006/42/EC", the following information is stamped onto the CE plate. For quick reference, record this information in the spaces that are provided.

- Primary Engine Power (kW) \_\_\_\_\_
- Additional Engine Power (kW) \_\_\_\_\_
- Typical Machine Operating Weight (kg) \_\_\_\_\_
- Year of Construction \_\_\_\_\_
- Machine Type \_\_\_\_\_

For the name, the address and the country of origin for the manufacturer, see the PIN plate.

## Eurasian Economic Union

For machines compliant to the Eurasian Economic Union requirements, the EAC mark plate is positioned near the Product Identification Number (PIN) plate (see Product Information Section of the machine Operation and Maintenance Manual). The EAC mark plate is placed on machines certified to the Eurasian Economic Union requirements effective at the time of market entry.



Illustration 59

g06094564

The Month and Year of Manufacture are on the PIN plate.

## Manufacturer Information

Manufacturer:

Caterpillar Inc.,  
100 N.E. Adams Street  
Peoria, Illinois 61629, USA

Entity authorized by the manufacturer at the territory of Eurasian Economic Union:

Caterpillar Eurasia LLC  
75, Sadovnicheskaya Emb.  
Moscow 115035, Russia

i02020554

## Emissions Certification Film

**SMCS Code:** 1000; 7000; 7405

**Note:** This information is pertinent in the United States, in Canada and in Europe.

The emission certification films are located on the engine.

Typical examples are shown.

| Perkins   |                            | IMPORTANT ENGINE INFORMATION |     |    |                         |
|---|----------------------------|------------------------------|-----|----|-------------------------|
| ENGINE FAMILY   | INITIAL INJECTION TIMING   |                              |     |    |                         |
| ENGINE TYPE   | FUEL RATE AT ADVERTISED kW |                              |     |    | mm <sup>3</sup> /STROKE |
| ENGINE NO.  | DISPLACEMENT               | L                            | EII | 96 |                         |
| ADVERTISED kW AT RPM  | IDLE RPM                   |                              |     | 24 |                         |
| VALVE LASH COLD (INCHES)  | EXH.                       | INLET                        |     |    |                         |
| EMISSION CONTROL SYSTEM   |                            | e11-97/68                    |     |    |                         |
| SETTINGS ARE TO BE MADE WITH ENGINE AT NORMAL OPERATING TEMPERATURE<br>TRANSMISSION IN NEUTRAL  |                            |                              |     |    |                         |
| THIS ENGINE CONFORMS TO U.S. EPA AND CALIFORNIA REGULATIONS<br>LARGE NON-ROAD COMPRESSION-IGNITION ENGINES<br>THIS ENGINE IS CERTIFIED TO OPERATE ON COMMERCIALY AVAILABLE<br>DIESEL FUEL |                            |                              |     |    |                         |
|   |                            |                              |     |    | 3181A007                |

The EPA/EU Emissions Certification Film  
(if applicable) is located either on the side,  
the top, or the front of the engine.

| Perkins  |                                | RENSEIGNEMENTS IMPORTANTS SUR LE MOTEUR |     |    |                         |
|--|--------------------------------|---|-----|----|-------------------------|
| FAMILLE DU MOTEUR  | CALAGE D'INJECTION INITIAL     |   |     |    |                         |
| TYPE DE MOTEUR   | TAUX D'INJECTION AU kW ANNONCÉ |   |     |    | MM <sup>3</sup> /COURSE |
| NO DU MOTEUR   | CYLINDRÉE                      | L                                       | EII | 96 |                         |
| kW ANNONCÉ À TR/MIN  | RALENTI TR/MIN                 |   |     | 24 |                         |
| JEU DES SOUPAPES À FROID (POUCES)  | ÉCHAP                          | ADMISSION                               |     |    |                         |
| DISPOSITIF ANTIPOLLUTION   |                                | e11-97/68                               |     |    |                         |
| LES RÉGLAGES DOIVENT ÊTRE FAITS AVEC LE MOTEUR À LA TEMPÉRATURE<br>DE FONCTIONNEMENT NORMALE BOÎTE DE VITESSES AU POINT MORT<br>CE MOTEUR EST CONFORME AUX NORMES AMÉRICAINES EPA ET AUX RÉGLEMENTATIONS<br>DE LA CALIFORNIE GROS MOTEURS HORS-ROUTE À COMPRESSION-ALLUMAGE<br>CE MOTEUR EST HOMOLOGUÉ POUR FONCTIONNER AVEC DU CARBURANT DIESEL DU COMMERCE |                                |   |     |    |                         |
|  |                                |   |     |    | 3181A007                |

L'AUTOCOLLANT D'HOMOLOGATION DU DISPOSITIF ANTIPOLLUTION EPA/UE  
(SELON ÉQUIPEMENT) EST SITUÉ SOIT SUR LE CÔTÉ, SOIT SUR LE DESSUS DU MOTEUR  
SOIT SUR LE DEVANT DU MOTEUR.

Product Information Section  
Emissions Certification Film

 **IMPORTANT ENGINE INFORMATION**  
ENGINE DISPLACEMENT (6.4 LITRE)  
ENGINE FAMILY-2MVXL06.4DDD  
RATED OUTPUT 147HP/1800RPM  
LOW IDLE SPEED (BARE ENGINE) --- RPM  
FUEL INJECTION TIMING 6° BTDC  
VALVE LASH (COLD) 0.0098 INCH  
FUEL RATE AT RATED OUTPUT 90.4 mm<sup>3</sup>/st  
THIS ENGINE CONFORMS TO 2002  
CALIFORNIA & U.S. EPA REGULATIONS FOR  
OFF-ROAD COMPRESSION-IGNITION ENGINES.  
THIS ENGINE IS CERTIFIED TO  
OPERATE ON COMMERCIALY AVAILABLE  
DIESEL FUEL.  
MITSUBISHI HEAVY INDUSTRIES, LTD.  
34393-30701

EPA Emission Film  
RENSEIGNEMENTS IMPORTANTS SUR LE MOTEUR  
CYLINDRÉE MOTEUR (6,4  
LITRES)  
FAMILLE DU MOTEUR 2MVXL06.4DDD  
PUISSANCE NOMINALE 147 HP/1800 TR/MIN  
VITESSE AU RALENTI (MOTEUR NU) ---- TR/MIN  
CALAGE DE L'INJECTION 6° AVANT LE PMH  
JEU DES SOUPAPES (A FROID) 0,0098 PO  
TAUX D'INJECTION A LA PUISSANCE NOMINALE  
90,4 mm<sup>3</sup>/course  
CE MOTEUR EST CONFORME AUX RÉGLEMENTATIONS 2002  
DE LA CALIFORNIE ET DES AMÉRICAINES EPA  
POUR LES MOTEURS HORS-ROUTE A COMPRESSION-  
ALLUMAGE.  
CE MOTEUR EST HOMOLOGUÉ POUR FONCTIONNER AVEC  
DU CARBURANT DIESEL DU COMMERCE.  
MITSUBISHI HEAVY INDUSTRIES, LTD.  
34393-30701

Illustration 61

g00993817

Emission Certification Film for the EPA  
3044 engine

 ENGINE TYPE 3066TAA  
RATED OUTPUT 109.6kW/1800rpm  
ENGINE FAMILY SK-TAA  
EC TYPE-APPROVAL NO.  
e11\*97/68FA\*00/000\*0148\*00

TYPE DE MOTEUR 3066TAA  
PUISSANCE NOMINALE 109,6 kW/1800 tr/min  
FAMILLE DU MOTEUR SK-TAA  
TYPE CE - NO APPROBATION  
e11\*97/68FA\*00/000\*0148\*00

Illustration 62

g00995945

Emission Certification Film for the European Union  
3044 engine

## Declaration of Conformity

**SMCS Code:** 1000; 7000

Table 17

An EC Declaration of Conformity document was provided with the machine if the machine was manufactured to comply with specific requirements for the European Union. To determine the details of the applicable Directives, review the complete EC Declaration of Conformity provided with the machine. The extract shown below from an EC Declaration of Conformity for machines that are declared compliant to "2006/42/EC" applies only to those machines originally "CE" marked by the manufacturer listed and which have not since been modified.

### EC DECLARATION OF CONFORMITY OF MACHINERY

**Manufacturer:** Caterpillar Inc., 100 N.E. Adams Street, Peoria, Illinois 61629, USA

**Person authorized to compile the Technical File and to communicate relevant part (s) of the Technical File to the Authorities of European Union Member States on request:**

Standards & Regulations Manager, Caterpillar France S.A.S 40,  
Avenue Leon-Blum, B.P. 55, 38041 Grenoble Cedex 9, France

**I, the undersigned, \_\_\_\_\_, hereby certify that the construction equipment specified hereunder**

|              |                       |   |
|--------------|-----------------------|---|
| Description: | Generic Denomination: | Earth-moving Equipment                              |
|              | Function:             | Skid Steer loader                                   |
|              | Model/Type:           | 216B3, 226B3, 236B3, 242B3, 252B3 Skid Steer Loader |
|              | Serial Number:        |   |
|              | Commercial Name:      | Caterpillar   |

Fulfills all the relevant provisions of the following Directives

| Directives                                 | Notified Body       | Document No. |
|--|---------------------|--------------|
| 2006/42/EC                                 | N/A                 |              |
| 2000/14/EC amended by 2005/88/EC, Note (1) | A V Technology Ltd. |              |
| 2004/108/EC                                | N/A                 |              |
| 2014/30/EU                                 | N/A                 |              |

Note (1) Annex VI \_\_\_ Guaranteed Sound Power Level - \_\_\_ dB (A)  
 Representative Equipment Type Sound Power Level - \_\_\_ dB (A)  
 Engine Power per \_\_\_ - \_\_\_ kW Rated engine speed - \_\_\_ rpm  
 Technical Documentation accessible through person listed above authorized to compile the Technical File

**Done at:**

**Signature**

**Date:**

**Name/Position**

**Note:** The above information was correct as of November 2015, but may be subject to change. Refer to the individual declaration of conformity issued with the machine for exact details.

## Declaration of Conformity

**SMCS Code:** 1000; 7000

Table 18

An EC Declaration of Conformity document was provided with the machine if the machine was manufactured to comply with specific requirements for the European Union. To determine the details of the applicable Directives, review the complete EC Declaration of Conformity provided with the machine. The extract shown below from an EC Declaration of Conformity for machines that are declared compliant to "2006/42/EC" applies only to those machines originally "CE" marked by the manufacturer listed and which have not since been modified.

### EC DECLARATION OF CONFORMITY OF MACHINERY

**Manufacturer:** Caterpillar Inc., 100 N.E. Adams Street, Peoria, Illinois 61629, USA

**Person authorized to compile the Technical File and to communicate relevant part (s) of the Technical File to the Authorities of European Union Member States on request:**

Standards & Regulations Manager, Caterpillar France S.A.S 40,  
Avenue Leon-Blum, B.P. 55, 38041 Grenoble Cedex 9, France

**I, the undersigned, \_\_\_\_\_, hereby certify that the construction equipment specified hereunder**

|              |                       |                                   |
|--------------|-----------------------|-----------------------------------|
| Description: | Generic Denomination: | Earth moving Equipment            |
|              | Function:             | Multi-Terrain loader              |
|              | Model/Type:           | 247B3, 257B3 Multi-Terrain Loader |
|              | Serial Number:        |                                   |
|              | Commercial Name:      | Caterpillar                       |

Fulfills all the relevant provisions of the following Directives

| Directives                                 | Notified Body | Document No. |
|--|---------------|--------------|
| 2006/42/EC                                 | N/A           |              |
| 2000/14/EC amended by 2005/88/EC, Note (1) |               |              |
| 2004/108/EC                                | N/A           |              |
| 2014/30/EU                                 | N/A           |              |

Note (1) Annex - \_\_\_\_ Guaranteed Sound Power Level - \_\_\_\_ dB (A)  
 Representative Equipment Type Sound Power Level - \_\_\_\_ dB (A)  
 Engine Power per \_\_\_\_ - \_\_\_\_ kW Rated engine speed - \_\_\_\_ rpm  
 Technical Documentation accessible through person listed above authorized to compile the Technical File

**Done at:**

**Signature**

**Date:**

**Name/Position**

**Note:** The above information was correct as of April 2010, but may be subject to change. Refer to the individual declaration of conformity issued with the machine for exact details.

## Declaration of Conformity

**SMCS Code:** 1000; 7000

Table 19

An EC Declaration of Conformity document was provided with the machine if the machine was manufactured to comply with specific requirements for the European Union. To determine the details of the applicable Directives, review the complete EC Declaration of Conformity provided with the machine. The extract shown below from an EC Declaration of Conformity for machines that are declared compliant to "2006/42/EC" applies only to those machines originally "CE" marked by the manufacturer listed and which have not since been modified.

### EC DECLARATION OF CONFORMITY OF MACHINERY

**Manufacturer:** Caterpillar Inc., 100 N.E. Adams Street, Peoria, Illinois 61629, USA

**Person authorized to compile the Technical File and to communicate relevant part (s) of the Technical File to the Authorities of European Union Member States on request:**

Standards & Regulations Manager, Caterpillar France S.A.S 40,  
Avenue Leon-Blum, B.P. 55, 38041 Grenoble Cedex 9, France

**I, the undersigned, \_\_\_\_\_, hereby certify that the construction equipment specified hereunder**

|              |                       |                            |
|--------------|-----------------------|----------------------------|
| Description: | Generic Denomination: | Earth moving Equipment     |
|              | Function:             | Compact Track loader       |
|              | Model/Type:           | 259B3 Compact Track Loader |
|              | Serial Number:        |                            |
|              | Commercial Name:      | Caterpillar                |

Fulfills all the relevant provisions of the following Directives

| Directives                                 | Notified Body | Document No. |
|--|---------------|--------------|
| 2006/42/EC                                 | N/A           |              |
| 2000/14/EC amended by 2005/88/EC, Note (1) |               |              |
| 2004/108/EC                                | N/A           |              |
| 2014/30/EU                                 | N/A           |              |

Note (1) Annex - \_\_\_\_ Guaranteed Sound Power Level - \_\_\_\_dB (A)  
 Representative Equipment Type Sound Power Level - \_\_\_\_dB (A)  
 Engine Power per \_\_\_\_-\_\_\_\_ kW Rated engine speed - \_\_\_\_ rpm  
 Technical Documentation accessible through person listed above authorized to compile the Technical File

**Done at:**

**Signature**

**Date:**

**Name/Position**

**Note:** The above information was correct as of April 2010, but may be subject to change. Refer to the individual declaration of conformity issued with the machine for exact details.

## Declaration of Conformity

**SMCS Code:** 1000; 7000

Table 20

An EC or EU Declaration of Conformity document was provided with the machine if it was manufactured to comply with specific requirements for the European Union. In order to determine the details of the applicable Directives, review the complete EC or EU Declaration of Conformity provided with the machine. The extract shown below from an EC or EU Declaration of Conformity for machines that are declared compliant to "2006/42/EC" applies only to those machines originally "CE" marked by the manufacturer listed and which have not since been modified.

### Original EC or EU DECLARATION OF CONFORMITY

**Manufacturer:**

Caterpillar Inc., 100 N.E. Adams Street, Peoria, Illinois 61629, USA

**Person authorized to compile the Technical File and to communicate relevant part (s) of the Technical File to the Authorities of European Union Member States on request:**

Standards & Regulations Manager, Caterpillar France SAS  
40 Avenue Leon-Blum 38000 Grenoble , France

**I, the undersigned, \_\_\_\_\_, hereby certify that the construction equipment specified hereunder**

|              |                       |   |
|--------------|-----------------------|---|
| Description: | Generic Denomination: | Earth-moving Equipment                            |
|              | Function:             | Bucket with Top Clamp                             |
|              | Model/Type:           | Industrial Grapple Bucket, Utility Grapple Bucket |
|              | Serial Number:        |   |
|              | Commercial Name:      | Caterpillar                                       |

Fulfills all the relevant provisions of the following Directives

| Directives | Notified Body | Document No. |
|------------|---------------|--------------|
| 2006/42/EC | N/A           |              |
| 2014/30/EU | N/A           |              |

Note (1) Technical Documentation accessible through person listed above authorized to compile the Technical File

**Done at:**

**Signature**

**Date:**

**Name/Position**

**Note:** The above information was correct as of January 2016, but may be subject to change, please refer to the individual Declaration of Conformity issued with the machine for exact details.

## Declaration of Conformity

**SMCS Code:** 1000; 7000

Table 21

An EC Declaration of Conformity document was provided with the machine if it was manufactured to comply with specific requirements for the European Union. In order to determine the details of the applicable Directives, review the complete EC Declaration of Conformity provided with the machine. The extract shown below from an EC Declaration of Conformity for machines that are declared compliant to "2006/42/EC" applies only to those machines originally "CE" marked by the manufacturer listed and which have not since been modified.

### EC DECLARATION OF CONFORMITY OF MACHINERY

**Manufacturer:**

Caterpillar Inc., 100 N.E. Adams Street, Peoria, Illinois 61629, USA

**Person authorized to compile the Technical File and to communicate relevant part (s) of the Technical File to the Authorities of European Union Member States on request:**

Standards & Regulations Manager, Caterpillar France SAS  
40 Avenue Leon-Blum 38000 Grenoble , France

**I, the undersigned, \_\_\_\_\_, hereby certify that the construction equipment specified hereunder**

|              |                       |                         |
|--------------|-----------------------|-------------------------|
| Description: | Generic Denomination: | Earth-moving Equipment  |
|              | Function:             | Rake with Top Clamp     |
|              | Model/Type:           | Industrial Grapple Rake |
|              | Serial Number:        |                         |
|              | Commercial Name:      | Caterpillar             |

Fulfills all the relevant provisions of the following Directives

| Directives | Notified Body | Document No. |
|------------|---------------|--------------|
| 2006/42/EC | N/A           |              |
| 2014/30/EU | N/A           |              |

Note (1) Technical Documentation accessible through person listed above authorized to compile the Technical File

**Done at:**

**Signature**

**Date:**

**Name/Position**

**Note:** The above information was correct as of May 2013, but may be subject to change, please refer to the individual declaration of conformity issued with the machine for exact details.

## Declaration of Conformity

**SMCS Code:** 1000; 7000

Table 22

An EC or EU Declaration of Conformity document was provided with the machine if it was manufactured to comply with specific requirements for the European Union. In order to determine the details of the applicable Directives, review the complete EC or EU Declaration of Conformity provided with the machine. The extract shown below from an EC or EU Declaration of Conformity for machines that are declared compliant to "2006/42/EC" applies only to those machines originally "CE" marked by the manufacturer listed and which have not since been modified.

### Original EC or EU DECLARATION OF CONFORMITY

**Manufacturer:**

Caterpillar Inc., 100 N.E. Adams Street, Peoria, Illinois 61629, USA

**Person authorized to compile the Technical File and to communicate relevant part (s) of the Technical File to the Authorities of European Union Member States on request:**Standards & Regulations Manager, Caterpillar France SAS  
40 Avenue Leon-Blum 38000 Grenoble , France**I, the undersigned, \_\_\_\_\_, hereby certify that the construction equipment specified hereunder**

|              |                       |   |
|--------------|-----------------------|---|
| Description: | Generic Denomination: | Earth-moving Equipment                        |
|              | Function:             | Fork with Top Clamp                           |
|              | Model/Type:           | Industrial Grapple Fork, Utility Grapple Fork |
|              | Serial Number:        |   |
|              | Commercial Name:      | Caterpillar                                   |

Fulfills all the relevant provisions of the following Directives

| Directives | Notified Body | Document No. |
|------------|---------------|--------------|
| 2006/42/EC | N/A           |              |
| 2014/30/EU | N/A           |              |

Note (1) Technical Documentation accessible through person listed above authorized to compile the Technical File

**Done at:****Signature****Date:****Name/Position**

**Note:** The above information was correct as of January 2016, but may be subject to change, please refer to the individual Declaration of Conformity issued with the machine for exact details.

## Declaration of Conformity

**SMCS Code:** 1000; 7000

Table 23

An EC or EU Declaration of Conformity document was provided with the machine if it was manufactured to comply with specific requirements for the European Union. In order to determine the details of the applicable Directives, review the complete EC or EU Declaration of Conformity provided with the machine. The extract shown below from an EC or EU Declaration of Conformity for machines that are declared compliant to "2006/42/EC" applies only to those machines originally "CE" marked by the manufacturer listed and which have not since been modified.

### Original EC or EU DECLARATION OF CONFORMITY

**Manufacturer:**

Caterpillar Inc., 100 N.E. Adams Street, Peoria, Illinois 61629, USA

**Person authorized to compile the Technical File and to communicate relevant part (s) of the Technical File to the Authorities of European Union Member States on request:**

Standards & Regulations Manager, Caterpillar France SAS  
40 Avenue Leon-Blum 38000 Grenoble, France

I, the undersigned, \_\_\_\_\_, hereby certify that the construction equipment specified hereunder

|              |                       |                          |
|--------------|-----------------------|--------------------------|
| Description: | Generic Denomination: | Earth-moving Equipment   |
|              | Function:             | Multipurpose Bucket      |
|              | Model/Type:           | Multipurpose (MP) Bucket |
|              | Serial Number:        |                          |
|              | Commercial Name:      | Caterpillar              |

Fulfills all the relevant provisions of the following Directives

| Directives | Notified Body | Document No. |
|------------|---------------|--------------|
| 2006/42/EC | N/A           |              |
| 2014/30/EU | N/A           |              |

Note (1) Technical Documentation accessible through person listed above authorized to compile the Technical File

**Done at:**

**Signature**

**Date:**

**Name/Position**

**Note:** The above information was correct as of February 2016, but may be subject to change, please refer to the individual declaration of conformity issued with the machine for exact details.

## Declaration of Conformity

**SMCS Code:** 1000; 7000

Table 24

An EC or EU Declaration of Conformity document was provided with the machine if it was manufactured to comply with specific requirements for the European Union. In order to determine the details of the applicable Directives, review the complete EC or EU Declaration of Conformity provided with the machine. The extract shown below from an EC or EU Declaration of Conformity for machines that are declared compliant to "2006/42/EC" applies only to those machines originally "CE" marked by the manufacturer listed and which have not since been modified.

### Original EC or EU DECLARATION OF CONFORMITY

**Manufacturer:**

Caterpillar Inc., 100 N.E. Adams Street, Peoria, Illinois 61629, USA

**Person authorized to compile the Technical File and to communicate relevant part (s) of the Technical File to the Authorities of European Union Member States on request:**

Standards & Regulations Manager, Caterpillar France SAS  
40 Avenue Leon-Blum 38000 Grenoble, France

I, the undersigned, \_\_\_\_\_, hereby certify that the construction equipment specified hereunder

|              |                       |   |
|--------------|-----------------------|---|
| Description: | Generic Denomination: | Earth-moving Equipment                                |
|              | Function:             | Material Handling Arm                                 |
|              | Model/Type:           | Material Handling Arm (MHA), Truss Boom, Lifting Hook |
|              | Serial Number:        |   |

Commercial Name: Caterpillar

Fulfills all the relevant provisions of the following Directives

| Directives | Notified Body | Document No. |
|------------|---------------|--------------|
| 2006/42/EC | N/A           |              |
| 2014/30/EU | N/A           |              |

Note (1) Technical Documentation accessible through person listed above authorized to compile the Technical File

**Done at:**

**Signature**

**Date:**

**Name/Position**

**Note:** The above information was correct as of January 2016, but may be subject to change, please refer to the individual Declaration of Conformity issued with the machine for exact details.

## Operation Section

### Before Operation

i04021647

### Mounting and Dismounting

SMCS Code: 7000

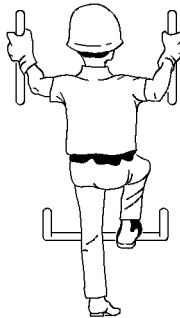

Illustration 63

g00037860

Typical example

Mount the machine and dismount the machine only at locations that have steps and/or handholds. Before you mount the machine, clean the steps and the handholds. Inspect the steps and handholds. Make all necessary repairs.

Face the machine whenever you get on the machine and whenever you get off the machine.

Maintain a three-point contact with the steps and with the handholds.

**Note:** Three-point contact can be two feet and one hand. Three-point contact can also be one foot and two hands.

Do not mount a moving machine. Do not dismount a moving machine. Never jump off the machine. Do not carry tools or supplies when you try to mount the machine or when you try to dismount the machine. Use a hand line to pull equipment onto the platform. Do not use any controls as handholds when you enter the operator compartment or when you exit the operator compartment.

### Machine Access System Specifications

The machine access system has been designed to meet the intent of the technical requirements in "ISO 2867 Earth-moving Machinery – Access Systems". The access system provides for operator access to the operator station and to conduct the maintenance procedures described in Maintenance section.

### Alternate Exit

Machines that are equipped with cabs have alternate exits. For additional information, see Operation and Maintenance Manual, "Alternate Exit".

i04394910

### Daily Inspection

SMCS Code: 1000; 7000

#### NOTICE

Accumulated grease and oil on a machine is a fire hazard. Remove this debris with steam cleaning or high pressure water, at least every 1000 hours or each time any significant quantity of oil is spilled on a machine.

For maximum service life of the machine, make a thorough daily inspection before you operate the machine. Inspect the machine for leaks. Remove any debris from the engine compartment and the undercarriage. Ensure that all guards, covers, and caps are secured. Inspect all hoses and belts for damage. Make the needed repairs before you operate the machine.

Inspect the area around the machine and under the machine. Inspect the machine components and lines for defects. Look for loose bolts, trash buildup, oil, coolant, fuel, or exhaust leakage, broken parts, or worn parts.

**Note:** Watch closely for leaks. If you observe a leak, find the source of the leak and correct the leak. If you suspect a leak or you observe a leak, check the fluid levels more frequently.

Inspect the condition of the equipment and of the hydraulic components.

Check all of the oil levels, all of the coolant levels, and all of the fuel levels.

Remove any trash buildup and debris. Make all necessary repairs before you operate the machine.

Make sure that all covers and guards are securely attached.

Adjust the mirrors for the correct rear view of the machine.

Grease the work tool on a daily basis.

Operation Section  
Daily Inspection

---

Daily, perform the procedures that are applicable to your machine. Refer to the Operation and Maintenance Manual, "Maintenance Interval Schedule" "Every 10 Service Hours or Daily" category for the list of procedures.

## Machine Operation

i03879235

### Alternate Exit

SMCS Code: 7000

### Primary Exit

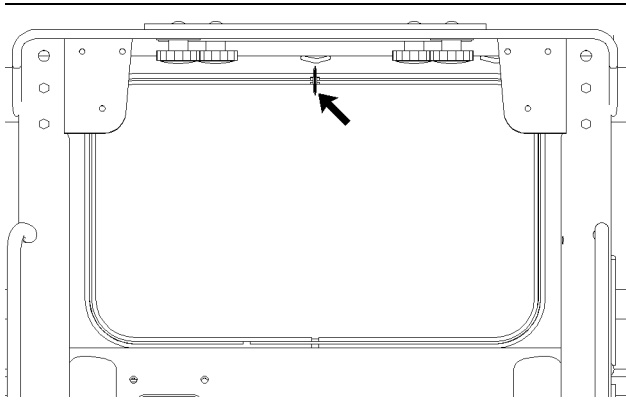

Illustration 64

g00929616

The opening in the rear of the machine serves as an alternate exit. The window (if equipped) will need to be removed in order to use the alternate exit.

The window can be removed by pulling on the ring at the top of the window. This will remove the seal that holds the window in place. When the seal is taken out, carefully remove the window.

### Secondary Exit

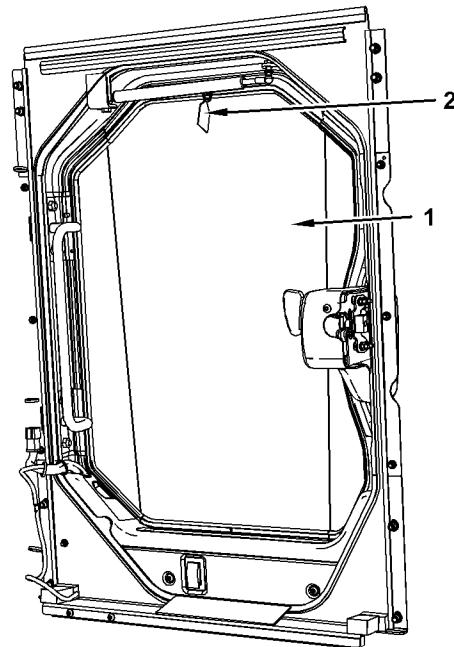

Illustration 65

g01398188

If the machine is equipped with a polycarbonate door, the opening (1) in the door may serve as an alternate exit. The window will need to be removed in order to use the alternate exit.

The window can be removed by pulling on the ring (2) at the top of the window. This will remove the seal that holds the window in place. When the seal is taken out, carefully remove the window.

i04200349

### Seat Belt

SMCS Code: 7327

**Note:** This machine was equipped with a seat belt when the machine was shipped from Caterpillar. At the time of installation, the seat belt and the instructions for installation of the seat belt meet the SAE J386 and ISO 6683 standards. Consult your Cat dealer for all replacement parts.

Always check the condition of the seat belt and the condition of the mounting hardware before you operate the machine.

## Seat Belt Adjustment for Non-Retractable Seat Belts

Adjust both ends of the seat belt. The seat belt should be snug but comfortable.

### Lengthening the Seat Belt

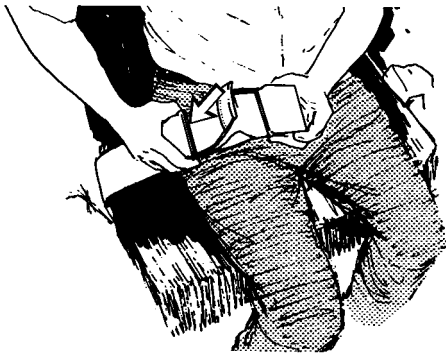

Illustration 66

g00100709

1. Unfasten the seat belt.

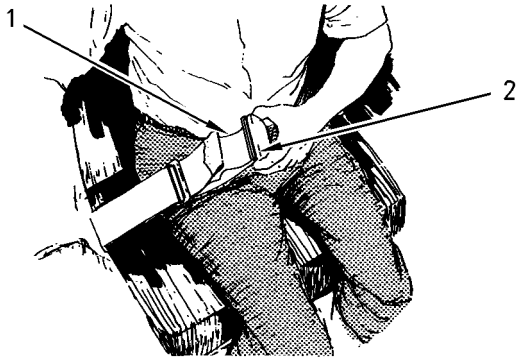

Illustration 67

g00932817

2. To remove the slack in outer loop (1), rotate buckle (2). This will free the lock bar. This permits the seat belt to move through the buckle.
3. Remove the slack from the outer belt loop by pulling on the buckle.
4. Loosen the other half of the seat belt in the same manner. If the seat belt does not fit snugly with the buckle in the center, readjust the seat belt.

### Shortening the Seat Belt

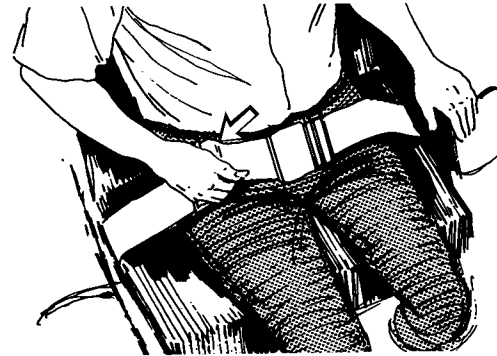

Illustration 68

g00100713

1. Fasten the seat belt. Pull out on the outer belt loop in order to tighten the seat belt.
2. Adjust the other half of the seat belt in the same manner.
3. If the seat belt does not fit snugly with the buckle in the center, readjust the seat belt.

### Fastening The Seat Belt

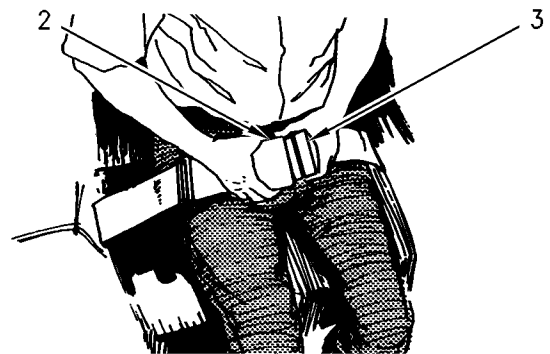

Illustration 69

g00932818

Fasten the seat belt catch (3) into the buckle (2). Make sure that the seat belt is placed low across the lap of the operator.

## Releasing The Seat Belt

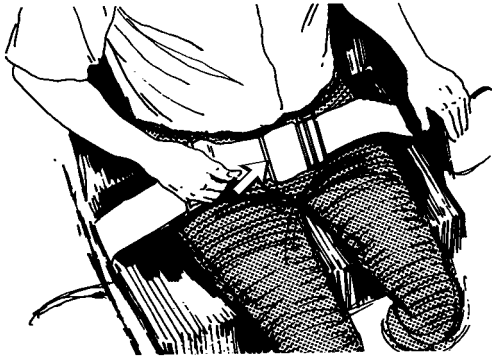

Illustration 70

g00100717

Pull up on the release lever. This will release the seat belt.

## Seat Belt Adjustment for Retractable Seat Belts

### Fastening The Seat Belt

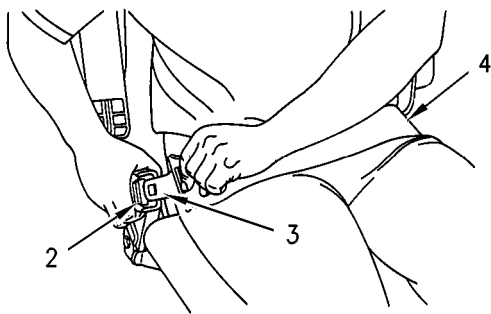

Illustration 71

g00867598

Pull seat belt (4) out of the retractor in a continuous motion.

Fasten seat belt catch (3) into buckle (2). Make sure that the seat belt is placed low across the lap of the operator.

The retractor will adjust the belt length and the retractor will lock in place. The comfort ride sleeve will allow the operator to have limited movement.

## Releasing The Seat Belt

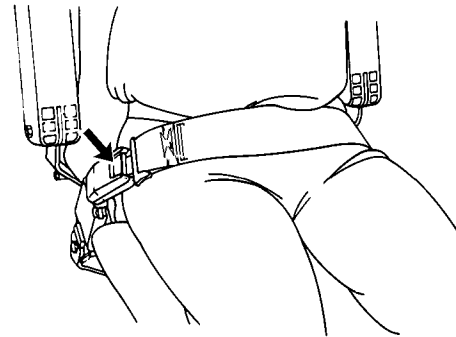

Illustration 72

g00039113

Push the release button on the buckle in order to release the seat belt. The seat belt will automatically retract into the retractor.

## Extension of the Seat Belt

### **⚠ WARNING**

When using retractable seat belts, do not use seat belt extensions, or personal injury or death can result.

The retractor system may or may not lock up depending on the length of the extension and the size of the person. If the retractor does not lock up, the seat belt will not retain the person.

Longer, non-retractable seat belts and extensions for the non-retractable seat belts are available.

Caterpillar requires only non-retractable seat belts to be used with a seat belt extension.

Consult your Cat dealer for longer seat belts and for information on extending the seat belts.

i06622510

## Operator Controls

**SMCS Code:** 7300; 7451

**Note:** Your machine may not be equipped with all the controls that are discussed in this topic.

The operation section is a reference for the new operator and a refresher for the experienced operator. This section includes descriptions of gauges, switches, machine controls, attachment controls, transportation, and towing information.

Illustrations guide the operator through correct procedures of checking, starting, operating, and stopping the machine. Operating techniques that are outlined in this publication are basic. Skill and techniques develop as the operator gains knowledge of the machine and the capabilities of the machine.

The following information briefly identifies the components of the cab. More information on the operation of each item is covered separately in this manual.

**Note:** Your machine may be equipped with a Dedicated Dual Direction Control Kit. The Dedicated Dual Direction Control Kit changes the control of the work tool and the movement of the machine. The other functions of the joysticks are not affected by the Dedicated Dual Direction Control Kit. Refer to the topic Dedicated Dual Direction Control Kit for details.

**Note:** Simple hydromechanical work tools may be shipped without hydraulic oil. Uneven movement may occur until all the air has been removed from the work tool. You may need to add hydraulic oil to the machine after the machine fills the circuits of the work tool. Refer to Operation and Maintenance Manual, "Hydraulic System Oil Level - Check" for the proper procedure for checking the hydraulic oil level.

**Note:** If the machine is not equipped with a cab that is enclosed, Caterpillar recommends the use of a flying object guard. If the machine is equipped with an enclosed cab, operate the machine with the cab door in the CLOSED position.

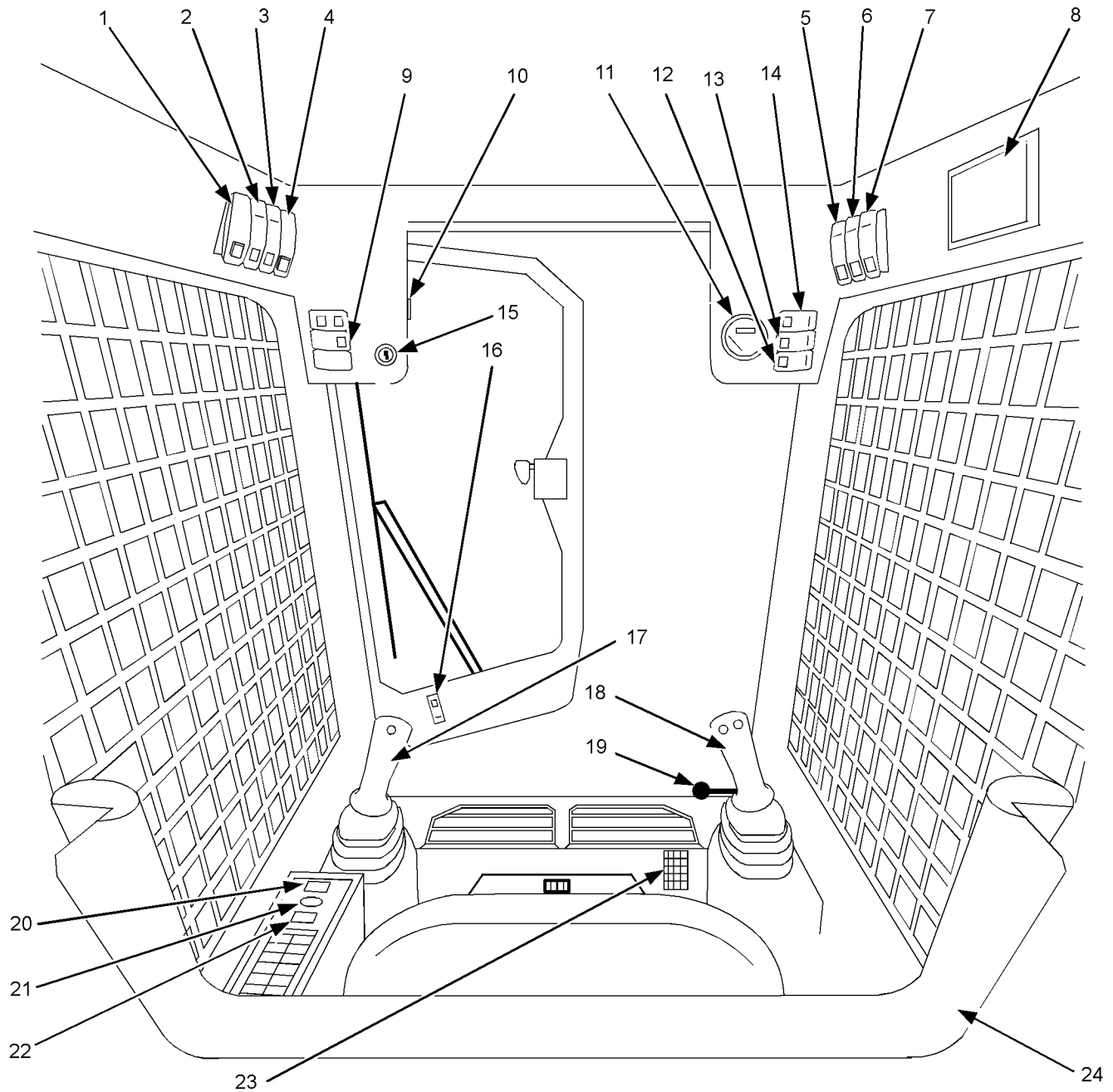

Illustration 73

g02386861

- (1) Auxiliary Hydraulic Pressure Release
- (2) Automatic Level Control
- (3) Auxiliary Electrical Control
- (4) Work Tool Coupler Control
- (5) Rooding Lights
- (6) Hazard Flashers
- (7) Hydraulic Lockout and Interlock Override
- (8) Cab Light

- (9) Parking Brake
- (10) Service Hour Meter
- (11) Fuel Level Gauge
- (12) Rear Work Lights
- (13) Front Work Lights
- (14) Turn Signals
- (15) Engine Start Switch
- (16) Window Wiper and Window Washer

- (17) Joystick Control
- (18) Joystick Control
- (19) Governor Control
- (20) Air Conditioning Control
- (21) Temperature Control
- (22) Fan Speed Control
- (23) Accelerator Control
- (24) Interlock Control

## Auxiliary Hydraulic Pressure Release (1)

### WARNING

Personal injury or death can result from the work tool falling.

Fully lower the loader arms before you release the hydraulic system pressure.

**Auxiliary Hydraulic Pressure Release** – Turn the ignition switch to the OFF position. Turn the ignition switch to the ON position. Release the parking brake. Push up on the locking tab. Press the bottom of the switch to release the pressure in the Standard Flow Auxiliary Circuit and the High Flow Auxiliary Circuit. Hold the switch for 4 to 5 seconds and release the switch.

**Note:** The operator must remain in the seat with the armrests in the LOWERED position in order for the control to function.

**Note:** The pressure in the secondary circuit is not affected by this switch. Refer to Operation and Maintenance Manual, “Work Tool Coupler Operation : Secondary Auxiliary Circuit” for the procedure to release the pressure.

## Automatic Level Control (2)



**Automatic Level Control** – The Automatic Level Control maintains the approximate selected angle of the work tool as the loader lift arms are raised. Press the bottom of the switch to activate the automatic level control. Press the top of the switch to deactivate the automatic level control.

**Note:** The Automatic Level Control keeps a load at the selected angle when the lift arms are raised. The Automatic Level Control is not designed to maintain the selected angle of the work tool when the lift arms are lowered.

## Auxiliary Electrical Control (3)

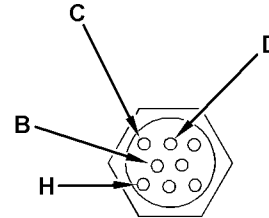

Illustration 74

g01107114

Typical electrical connection on the loading arm (Early models)

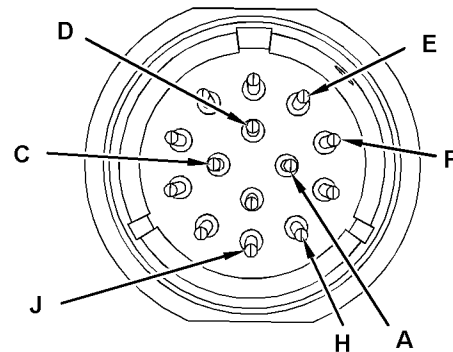

Illustration 75

g02580530

Typical electrical connection on the loading arm (Later models)

- (A) Right-Hand Trigger Control
- (B) C- Control
- (C) C+ Control
- (D) C2 Control
- (E) C1 Control
- (J) Control



**Auxiliary Electrical Control –** The auxiliary electrical control supplies continuous electrical power to pin (H) that is on the loader arm. Press the bottom of the switch to turn on electrical power. Press the top of the switch to turn off electrical power.

## Work Tool Coupler Control (4)

### WARNING

Improper Attachment of the Work Tool could result in injury or death.

Do not operate the machine without confirmation that the coupler pins are fully engaged. Follow the operating procedures in the Operation and Maintenance Manual.

**Work Tool Coupler Control –** The work tool coupler control controls the engagement of the coupler pins.



**Disengaged –** Pull the red button downward and press the bottom of the switch. Hold the switch in the downward position until the coupler pins disengage.



**Engaged –** Press the top of the switch and hold the top of the switch until the coupler pins engage.

Refer to Operation and Maintenance Manual, “Work Tool Coupler Operation” for the proper procedure for the work tool coupler.

## Roading Lights (5)



**Roading Lights –** Move the switch to the middle position to turn on the control panel lights and position lights. Press the bottom of the switch to turn on the front low beams. Press the top of the switch to turn off the lights.

## Hazard Flashers (6)



**Hazard Flasher Control –** Press the top of the switch to activate the hazard flashers. Press the bottom of the switch to deactivate the hazard flashers.

## Hydraulic Lockout and Interlock Override (7)



**Hydraulic Lockout –** Press the top of the switch to disable the hydraulic functions. Press the top of the switch again to activate the hydraulic functions.

**Note:** Activate the hydraulic shutoff when you are roading the machine to prevent unplanned movement of the work tool and the loader arms.



**Interlock Override –** The interlock override allows the auxiliary hydraulic circuits to function with the armrest in the RAISED position. First activate the continuous flow control that is on the left side joystick. Refer to the section “Joystick and Auxiliary Hydraulic Controls” for detailed information. Press the bottom of the interlock override switch to activate the interlock override function. To turn off the interlock override and continuous flow, press the bottom of the switch again.

### WARNING

Inadvertent movement of the work tool may occur if the interlock override function is used with work tools. This may result in personal injury or death. Only use interlock override function for hand-held work tools.

**Note:** The alert indicator for the parking brake will light when the interlock override is activated. When the interlock override is deactivated, press the parking brake switch to disengage the parking brake and activate the hydraulic functions.

### NOTICE

Do not leave the machine unattended while you have the interlock override function activated.

A switch is provided on the cab door that prevents implement operations when the cab door is open. If there is no cab door, install a jumper wire between Terminal 2 and Terminal 4 in the wiring harness connector for the Window Wiper. The jumper connector is located on the wiring harness just above the window washer fluid tank on the left side in the cab. Refer to Special Instruction, REHS1738, “Installing the Cab Door and Mounting Group” for more information about the cab door.

**Note:** When the door is installed, remove the jumper wire from the connector plug before you connect the harness. Damage to the door could occur if the jumper is left in place.

### Cab Dome Light (8)



**Cab Dome Light** – Press on either side of the light in order to turn on the light. Move the light to the middle position in order to turn off the light.

### Parking Brake Control (9)



**Parking Brake Control** – Press on the right side of the switch in order to engage or disengage the parking brake.

**Note:** The parking brake will engage when the engine is stopped. The parking brake will engage when the armrest is moved to the RAISED position. The parking brake will engage when the operator leaves the operator seat for an extended time.

### Service Hour Meter (10)



**Service Hour Meter** – The service hour meter should be used to determine service hour maintenance intervals.

### Service Hour Meter (10A) (Only for prefixes PWK and DXZ)

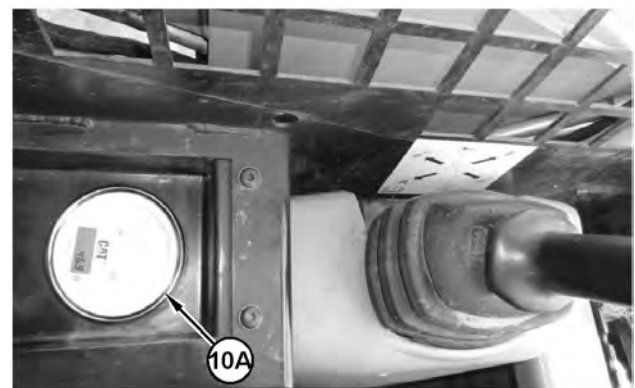

Illustration 76

g06008926



**Service Hour Meter** – The service hour meter should be used to determine service hour maintenance intervals.

### Fuel Level Gauge (11)



**Fuel Level Gauge** – The needle in the yellow range indicates low fuel.

### Rear Work Lights (12)



**Rear Work Lights** – Press the left side of the switch in order to turn on the lights. Press the right side of the switch in order to turn off the lights.

### Front Work Lights (13)



**Front Work Lights** – Press the left side of the switch in order to turn on the lights. Press the right side of the switch in order to turn off the lights.

## Turn Signals (14)



**Turn Signals** – Press on the left side of the switch in order to turn on the left turn signals. Press on the right side of the switch in order to turn on the right turn signals. Move the switch to the middle position in order to turn off the turn signals.

## Engine Start Switch (15)



**OFF** – Insert the engine start switch key only from the OFF position and remove the engine start switch key only from the OFF position. Turn the engine start switch key to the OFF position in order to stop the engine. In the OFF position, there is no power to most electrical circuits on the machine. The cab lights, panel lights, tail lights, working lights (if equipped), and fuel gauge light are operational even when the engine start switch is in the OFF position.



**ON** – Turn the engine start switch key clockwise to the ON position in order to activate all of the cab circuits.



**START** – Turn the engine start switch key clockwise to the START position in order to crank the engine. Release the engine start switch key after the engine starts and the engine start switch key returns to the ON position.

**Note:** For more information on engine starting, refer to Operation and Maintenance Manual, “Engine Starting”.

**Note:** If the engine fails to start, turn the engine start switch key to the OFF position. Attempt to start the engine again.

## Engine Start Switch (15A) (Only for prefixes PWK and DXZ)



**OFF** – Insert the engine start switch key only from the OFF position and remove the engine start switch key only from the OFF position. Turn the engine start switch key to the OFF position in order to stop the engine. In the OFF position, there is no power to most electrical circuits on the machine. The cab lights, panel lights, tail lights, working lights (if equipped), and fuel gauge light are operational even when the engine start switch is in the OFF position.



**ON** – Turn the engine start switch key clockwise to the ON position in order to activate all of the cab circuits.



**START** – Turn the engine start switch key clockwise to the START position in order to crank the engine. Release the engine start switch key after the engine starts and the engine start switch key returns to the ON position.

**Note:** For more information on engine starting, refer to Operation and Maintenance Manual, “Engine Starting”.

**Note:** If the engine fails to start, turn the engine start switch key to the OFF position. Attempt to start the engine again.

## Window Wiper and Window Washer (16)



**Window Wiper and Window Washer** – Move the switch to the middle position in order to turn on the wiper. Press on the right side of the switch in order to operate the washer. Press on the left side of the switch in order to turn off the wipers.

## Joystick Control (17)

Refer to the section “Joystick and Auxiliary Hydraulic Controls” for detailed information.

## Joystick Control (18)

Refer to the section “Joystick and Auxiliary Hydraulic Controls” for detailed information.

## Governor Control (19)

**Governor Control** – Use the governor control when you want to set a constant engine speed. Move the lever forward in order to increase engine speed. Move the lever backward in order to decrease engine speed.



**High Idle**



**Low Idle**

## Air Conditioner Control (20)



**Air Conditioner Control** – Press the left side of the switch in order to turn on the air conditioning. Press the right side of the switch in order to turn off the air conditioning.

## Temperature Control (21)



**Temperature Control** – The temperature control knob is a rotary switch. Turn the knob clockwise for warmer air. Turn the knob counterclockwise for cooler air.

## Fan Speed Control (22)



**Fan Speed Control** – Press the left side of the switch for high fan speed. Press the right side of the switch for low fan speed. Move the switch to the middle position in order to turn off the fan.

## Accelerator Control (23)



**Accelerator Control** – Push down on the accelerator pedal in order to increase engine speed. Release the accelerator pedal in order to decrease engine speed. The accelerator pedal will return to the setting of the governor control.

## Interlock Control (24)

**Interlock Control** – Move the armrest to the RAISED position in order to lock out the hydraulic controls.

**Note:** When the armrest is moved to the RAISED position, the parking brake will engage. Move the armrest to the LOWERED position and push the switch for the parking brake in order to activate the hydraulic controls.

**Note:** When you start the engine, the parking brake must be disengaged in order for the hydraulic controls to be activated. If the armrest is raised and lowered during operation, disengage the parking brake in order for the hydraulic controls to be activated.

## Seat

### Standard Seat

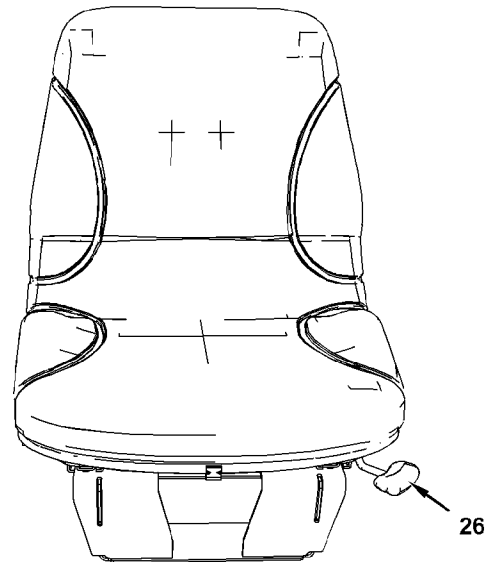

Illustration 77

g02155176

(26) Fore/Aft Adjustment



**Standard Seat**

## Suspension Seat

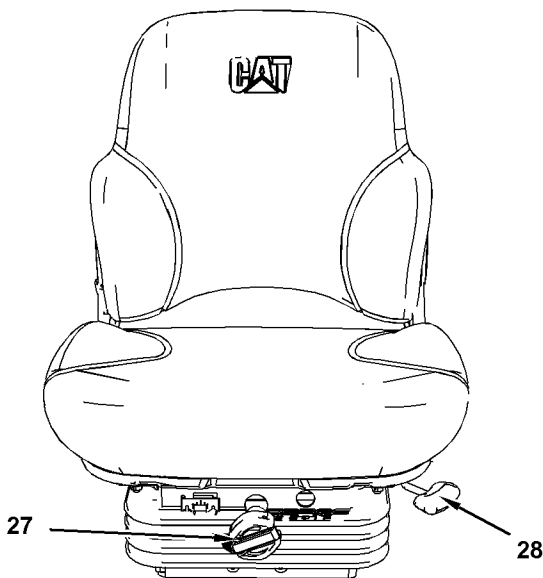

Illustration 78

g02125925

(27) Height Adjustment  
(28) Fore/Aft Adjustment

**Height Adjustment (27)** – Turn the knob in order to adjust the suspension of the seat. Turn the knob clockwise for a heavier person. Turn the knob counterclockwise for a lighter person.

**Fore/Aft lever (28)** – Move the lever in order to adjust the seat.

## Roading Lights (Only for prefixes PWK and DXZ)



Illustration 79

g06008958



**Light On/Off** – Move the light on/off switch (29) to the middle position to turn on the control panel lights and position lights. Press the bottom of the switch (29) to activate (30) Low/High Beam switch. Press the top of the switch (29) to turn off the switch.



**High Beam** – Press the bottom of the switch (30) to turn on front high beam light.



**Low Beam** – Press the top of the switch (30) to turn on front low beam light.

**Note:** Low/High Beam switch (30) will work only light on/off switch (29) in bottom most position.

## Joystick and Auxiliary Hydraulic Controls

The joystick controls the functions that are listed below. Your machine may not be equipped with all the controls that are discussed in this topic.

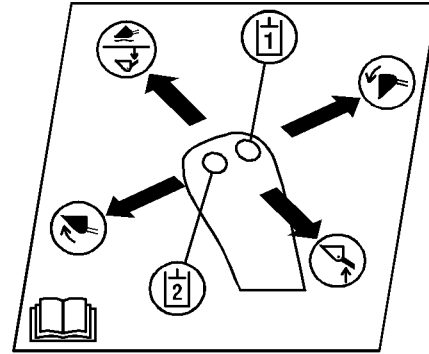
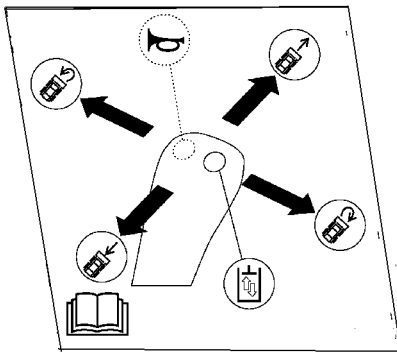

Illustration 80

g01112346

Instruction Decals A - Instruction Decal for Left-Hand Joystick and Instruction Decal for Right-Hand Joystick

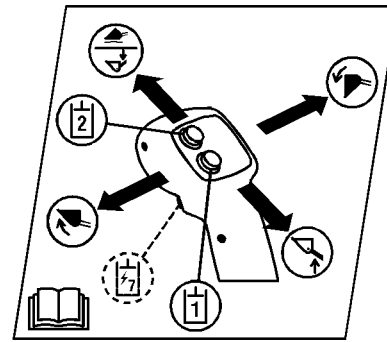
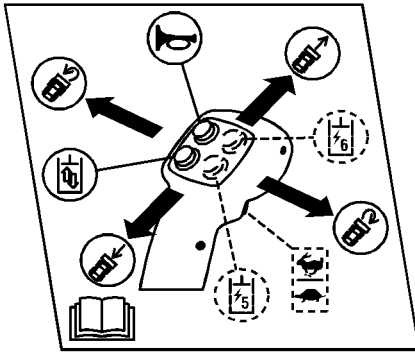

Illustration 81

g01112439

Instruction Decals B - Instruction Decal for Left-Hand Joystick and Instruction Decal for Right-Hand Joystick

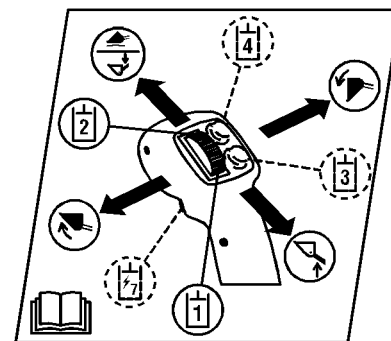
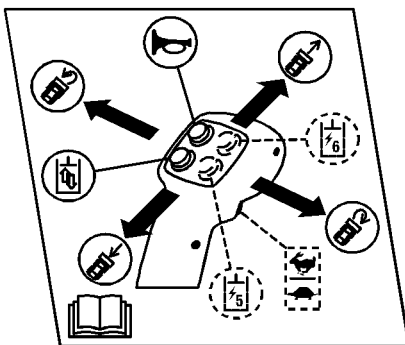

Illustration 82

g01112442

Instruction Decals C - Instruction Decal for Left-Hand Joystick and Instruction Decal for Right-Hand Joystick with Thumb Wheel

## Forward



**Forward Travel** – Push the joystick forward to travel forward.

## Backward



**Backward Travel** – Pull back on the joystick to travel in reverse.

## Right Turn



**Right Turn** – Move the joystick to the right to turn the machine to the right.

## Left Turn



**Left Turn** – Move the joystick to the left to turn the machine to the left.

## Dump



**Dump** – Move the joystick to the right to tilt the bucket downward.

## Raise



**Raise** – Pull the joystick backward to raise the bucket.

## Tilt Back



**Tilt Back** – Move the joystick to the left to tilt the bucket upward.

## Lower



**Lower** – Push the joystick forward to lower the bucket.

## Float



**Float** – Push the joystick forward into the detent in order for the bucket to follow the contour of the ground.

## Horn



**Horn** – Press the switch to sound the horn. Use the horn to alert personnel.

## Two Speed Control

**Note:** If rabbit mode is selected, the high flow control will not operate.



**Two Speed** – Press the switch on the front of the left-hand joystick to activate rabbit mode.

**Note:** Keep the work tool close to the ground when you travel in rabbit mode. The machine will be more stable.

## Joystick and Auxiliary Hydraulic Controls (Only for prefixes PWK and DXZ.)

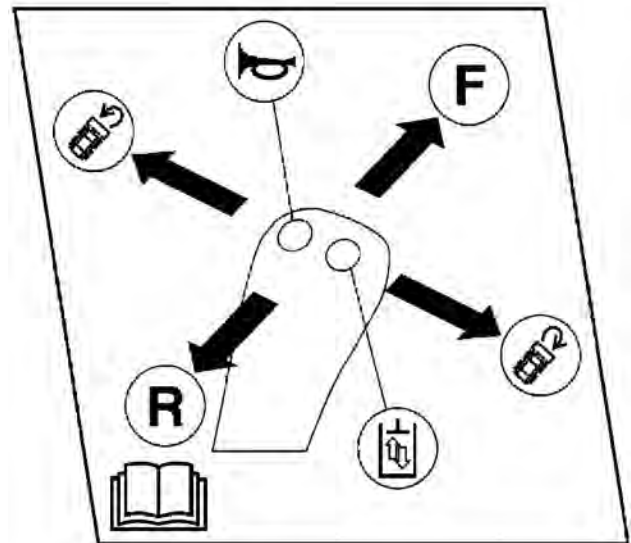

Illustration 83

g06009004



**F** **Forward Travel** – Push the joystick forward to travel forward.



**R** **Reverse Travel** – Push the joystick backward to travel reverse.



**Right Turn** – Move the joystick to the right to turn the machine to the right.



**Left Turn** – Move the joystick to the left to turn the machine to the left.



**Horn** – Press the switch to sound the horn. Use the horn to alert personnel.

## Auxiliary Work Tool Controls

### Early Models

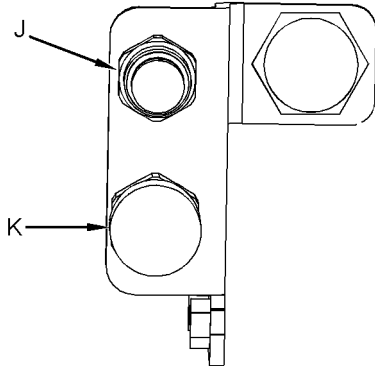

Illustration 84

g01106739

### Standard Auxiliary Connections

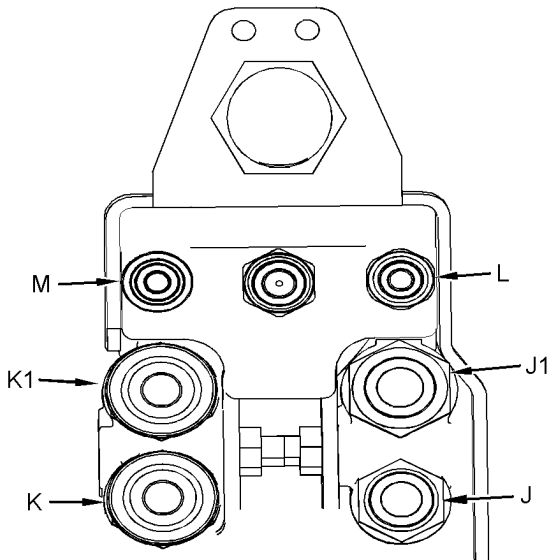

Illustration 85

g01106740

### Early Model High Flow



**Auxiliary Hydraulic Control (A1)** – This control provides hydraulic oil flow to the auxiliary connections on the loader arm. Engage the control to provide hydraulic oil flow to the connector (K). For high flow work tools, engage the control to provide hydraulic oil flow to the connector (K1).



**Auxiliary Hydraulic Control (A2)** – This control provides hydraulic oil flow to the auxiliary connections on the loader arm. Engage the control to provide hydraulic oil flow to the connector (J). For high flow work tools, engage the control to provide hydraulic oil flow to the connector (J1).



**Secondary Auxiliary Hydraulic Control (C-)** – This control provides hydraulic oil flow to the auxiliary connections on the loader arm. Press the control to provide hydraulic oil flow to the connector (M).



**Secondary Auxiliary Hydraulic Control (C+)** – This control provides hydraulic oil flow to the auxiliary connections on the loader arm. Press the control to provide hydraulic oil flow to the connector (L).

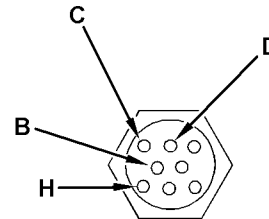

Illustration 86

g01107114

### Typical electrical connection on the loading arm



**Auxiliary Electrical Control (C2)** – This control provides electrical power to control a three-position diverter valve that is on some work tools. Press the switch and hold the switch to send power to the pin (D). Release the switch to deactivate the control.



**Auxiliary Electrical Control (C1)** – This control provides electrical power to control a three-position diverter valve that is on some work tools. Press the switch and hold the switch to send power to pin (C). Release the switch to deactivate the control.



**Right-Hand Trigger** – Pull the trigger and hold the trigger on the right-hand joystick to provide electrical power to pin (B). Release the trigger to deactivate the control.

## Later Models

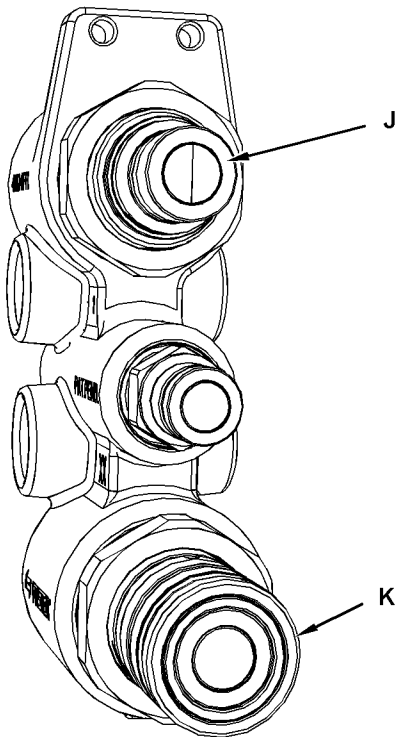

Illustration 87

g02555596

### Later Model High Flow



**Auxiliary Hydraulic Control (A1)** – This control provides hydraulic oil flow to the auxiliary connections on the loader arm.

Engage the control to provide hydraulic oil flow to the connector (K).



**Auxiliary Hydraulic Control (A2)** – This control provides hydraulic oil flow to the auxiliary connections on the loader arm.

Engage the control to provide hydraulic oil flow to the connector (J).



**Secondary Auxiliary Hydraulic Control (C-)** – This control provides electrical power to activate additional work tool functions using a three-position diverter valve that is on some work tools. Press the switch and hold the switch to send power to the pin (C) this will activate the required Work Tool function. Release the switch to deactivate the control. If the auxiliary hydraulic controls (1), (2), and continuous flow are inactive and a work tool featuring auto reverse functionality (such as cold planers) is connected, pressing the switch will send power to pin (C) and provide hydraulic flow to connector (K).

Press the switch and hold the switch to send power to the pin (C) this will activate the required Work Tool function. Release the switch to deactivate the control. If the auxiliary hydraulic controls (1), (2), and continuous flow are inactive and a work tool featuring auto reverse functionality (such as cold planers) is connected, pressing the switch will send power to pin (C) and provide hydraulic flow to connector (K).



**Secondary Auxiliary Hydraulic Control (C+)** – This control provides electrical power to activate additional work tool functions using a three-position diverter valve that is on some work tools. Press the switch and hold the switch to send power to the pin (D) this will activate the required Work Tool function. Release the switch to deactivate the control. If the auxiliary hydraulic controls (1), (2), and continuous flow are inactive and a work tool featuring auto reverse functionality (such as cold planers) is connected, pressing the switch will send power to pin (D) and provide hydraulic flow to connector (K).

Press the switch and hold the switch to send power to the pin (D) this will activate the required Work Tool function. Release the switch to deactivate the control. If the auxiliary hydraulic controls (1), (2), and continuous flow are inactive and a work tool featuring auto reverse functionality (such as cold planers) is connected, pressing the switch will send power to pin (D) and provide hydraulic flow to connector (K).

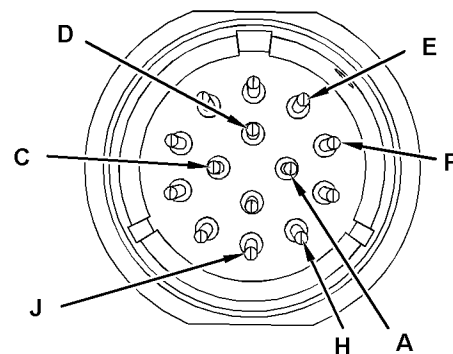

Illustration 88

g02580530

### Typical electrical connection on the loading arm (Later models)

- (A) Right-Hand Trigger Control
- (C) C- Control
- (D) C+ Control
- (E) C2 Control
- (F) C1 Control
- (J) Control



**Auxiliary Electrical Control (C2)** – This control provides electrical power to activate additional work tool functions using a three-position diverter valve that is on some work tools. Press the switch and hold the switch to send power to the pin (E) this will activate the required Work Tool function. Release the switch to deactivate the control. If the auxiliary hydraulic controls (1), (2), and continuous flow are inactive and a work tool featuring auto reverse functionality (such as cold planers) is connected, pressing the switch will send power to pin (E) and provide hydraulic flow to connector (K).

Press the switch and hold the switch to send power to the pin (E) this will activate the required Work Tool function. Release the switch to deactivate the control. If the auxiliary hydraulic controls (1), (2), and continuous flow are inactive and a work tool featuring auto reverse functionality (such as cold planers) is connected, pressing the switch will send power to pin (E) and provide hydraulic flow to connector (K).



**Auxiliary Electrical Control (C1) – This control provides electrical power to activate additional work tool functions using a three-position diverter valve that is on some work tools. Press the switch and hold the switch to send power to pin (F) this will activate the required Work Tool function. Release the switch to deactivate the control. If the auxiliary hydraulic controls (1), (2), and continuous flow are inactive and a work tool featuring auto reverse functionality (such as cold planers) is connected, pressing the switch will send power to pin (F) and provide hydraulic flow to connector (K).**



**Right-Hand Trigger – Pull the trigger and hold the trigger on the right-hand joystick to provide electrical power to pin (A). Release the trigger to deactivate the control.**

**Note:** These controls need to be used in conjunction with individual Work Tool Operation and Maintenance Manual to understand fully the functions of each control.

## Continuous Flow Control



**Continuous Flow – The continuous flow control supplies continuous flow of hydraulic fluid to the auxiliary hydraulic circuit without continuously holding the auxiliary hydraulic control. Press one of the two auxiliary hydraulic switches that are on the right side joystick. Press the continuous flow switch on the left-hand joystick and release the continuous flow switch. Immediately release the auxiliary hydraulic switch after you release the continuous flow switch. The continuous flow function will be activated if the operator releases the auxiliary hydraulic switch within one second of releasing the continuous flow switch. Press either the auxiliary hydraulic control or the continuous flow switch to stop the flow to the auxiliary circuit.**

## Dedicated Dual Direction Control Kit

**Note:** The following illustrations reflect the operation of the joysticks when the machine is equipped with a Dedicated Dual Direction Control Kit. The Dedicated Dual Direction Control Kit changes the control of the work tool and the movement of the machine. The other functions of the joysticks are not affected by the Dedicated Dual Direction Control Kit. The Dedicated Dual Direction Control Kit may be used with standard joysticks or optional joysticks.

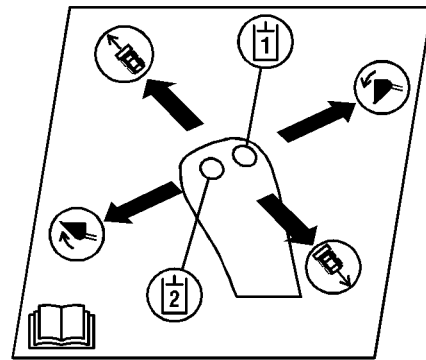
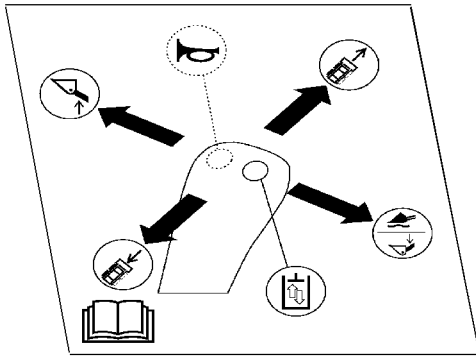

Illustration 89

g01112348

Instruction Decals A - Instruction Decal for Left Hand Dedicated Dual Direction Control Joystick and Instruction Decal for Right Hand Dedicated Dual Direction Control Joystick

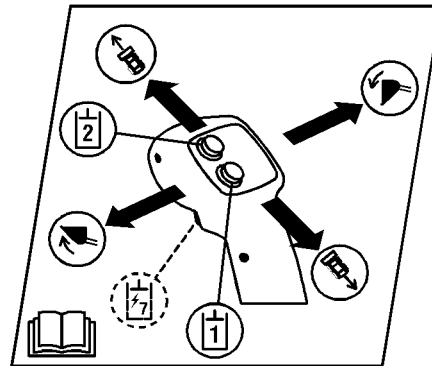
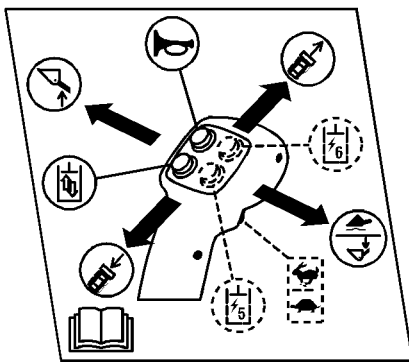

Illustration 90

g01112448

Instruction Decals B - Instruction Decal for Left Hand Dedicated Dual Direction Control Joystick and Instruction Decal for Right Hand Dedicated Dual Direction Control Joystick

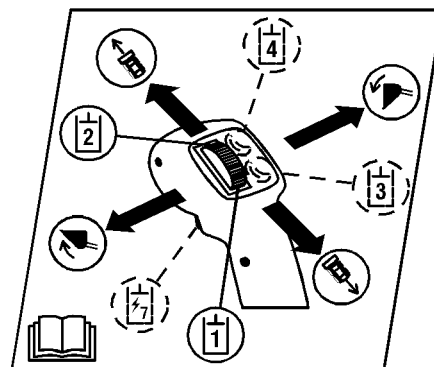
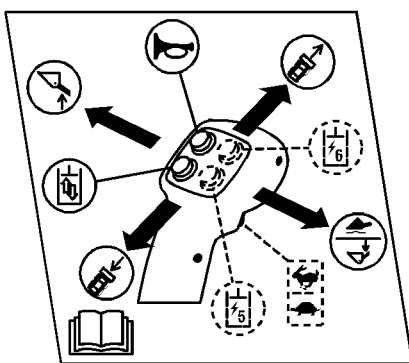

Illustration 91

g01112451

Instruction Decals C - Instruction Decal for Left Hand Dedicated Dual Direction Control Joystick and Instruction Decal for Right Hand Dedicated Dual Direction Control Joystick with Thumb Wheel

## Forward



**Forward** – Push both joysticks forward to move the machine forward.

## Reverse



**Reverse** – Pull both joysticks backward to move the machine backward.

## Right Turn

Push the left joystick forward to turn the machine to the right.

Push the left joystick forward and pull the right joystick backward to turn the machine rapidly to the right.

## Left Turn

Push the right joystick forward to turn the machine to the left.

Push the right joystick forward and pull the left joystick backward to turn the machine rapidly to the left.

## Float



**Float** – Move the joystick to the right into the detent in order for the bucket to follow the contour of the ground.

## Lower



**Lower** – Move the joystick to the right to lower the bucket.

## Raise



**Raise** – Move the joystick to the left to raise the bucket.

## Dump



**Dump** – Move the joystick to the right to tilt the bucket downward.

## Tilt Back



**Tilt Back** – Move the joystick to the left to tilt the bucket upward.

i03879447

## Alert Indicators

**SMCS Code:** 7450; 7451

The alert indicators are located on the left side and right side overhead consoles.

**Note:** Your machine may not be equipped with all of the indicators that are discussed in this topic.

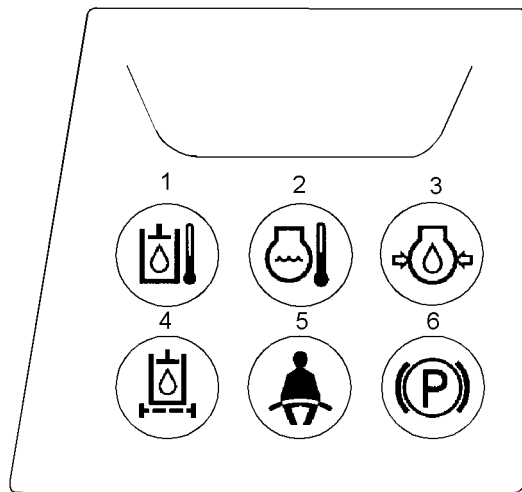

Illustration 92  
Left side

g01015590

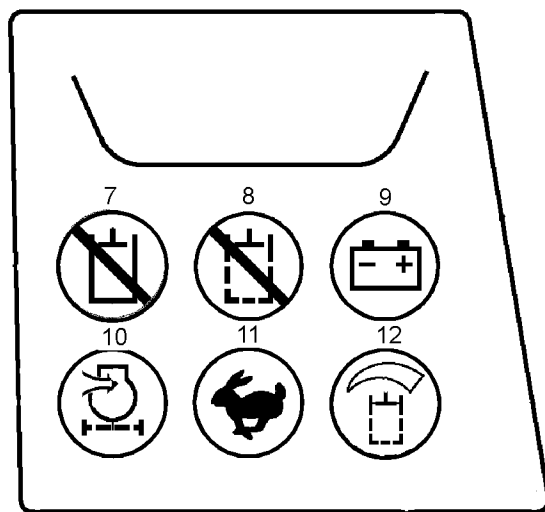

Illustration 93  
Right Side

g02125723

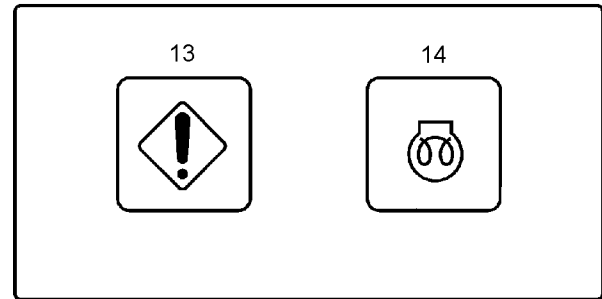





Illustration 94

g02125769

 **Hydraulic Oil Temperature (1)** – This alert indicator will light and an audible alert will sound when the temperature of the hydraulic oil is too high. If this indicator comes on, stop the machine immediately. Stop the engine and investigate the problem.

 **Engine Coolant (2)** – This alert indicator will light and an audible alert will sound when the engine coolant temperature is too high. If this alert indicator comes on, stop the machine immediately. Stop the engine and investigate the cause.

 **Engine Oil Pressure (3)** – This alert indicator will light and an audible alert will sound when the engine oil pressure is low. If this alert indicator comes on, stop the machine immediately. Stop the engine and investigate the cause.

 **Hydraulic Oil Filter (4)** – This indicator will light when the hydraulic oil filter is not functioning properly. Stop the machine and replace the oil filter. The indicator will stay on until the hydraulic oil has warmed up. Do not operate the machine until the light turns off.

 **Seat and Armrest (5)** – This alert indicator will light when the armrest is in the RAISED position. The alert indicator will light when the operator gets out of the operator seat. The alert indicator should go out when the operator is in the operator seat and the armrest is in the LOWERED position.

 **Parking Brake (6)** – This alert indicator will light when the parking brake is engaged. The alert indicator should come on during start-up. The alert indicator should go out when the parking brake is disengaged.



**Implement Lockout (7) – This alert indicator will light when the implement lockout control is activated.**



**Interlock Override (8) – This alert indicator will light when interlock override is activated.**



**Charging System (9) – This alert indicator will light if there is a malfunction in the electrical system. If this alert indicator comes on, the system voltage is too high for normal machine operation or too low for normal machine operation.**

If electrical loads are high and the engine speed is near low idle, increase the engine speed to high idle. This will generate more output from the alternator. If the alert indicator for the electrical system turns off within one minute, the electrical system is probably operating in a normal manner. However, the electrical system may be overloaded during periods of low engine speeds.

Increase the engine idle speed with the governor lever in order to compensate for a higher electrical load on the system.

If this procedure does not cause the alert indicator to turn off, move to a convenient location. Investigate the cause (loose alternator belt, broken alternator belt, faulty batteries, etc).



**Engine Air Filter (10) – This alert indicator will light if the engine air filter becomes restricted.**



**Rabbit Mode (11) – This alert indicator will light when rabbit mode is selected with the two-speed control.**

**Note:** High flow will not operate if rabbit mode has been selected with the two speed control.



**Hydraulic High Flow (12) – This alert indicator will light when the high flow hydraulic system is activated.**

**Note:** High Flow should not be operated in continuous flow mode.

**Note:** High flow will not operate if rabbit mode has been selected with the two speed control.

**Note:** If your High Flow work tool does not have a wiring harness, a Jumper Plug needs to be installed on the electrical plug for the work tool control. Without this Jumper Plug, the machine will not provide High Flow to the work tool. Please refer to your Parts Manual for the current part number for the Jumper Plug.

**Note:** High flow mode requires an electrical connection that is located on the loader arm. Refer to Operation and Maintenance Manual, “Work Tool Coupler Operation” or Operation and Maintenance Manual, “Work Tool Operation” for additional details.



**Driver Alert (13) – This alert indicator will activate when there is a problem which requires the operator's attention.**

**Note:** Other alert indicators that light or the gauges may help investigate the cause of any problems.

There are three levels of severity for the indicator:

- Level 1 - If the alert indicator is on continuously, stop the machine at the earliest convenience. Investigate the cause. If no additional alert indicators are illuminated, contact your Caterpillar dealer or refer to the service manual.
- Level 2 - If the alert indicator is flashing and there is no audible alarm, severe component damage could occur. Change your operation or perform the indicated maintenance.
- Level 3 - If the alert indicator is flashing and there is an audible alarm, injury to the operator or severe component damage could occur. Stop the machine immediately and stop the engine.



**Glow Plug Starting Aid (14) – With the engine start switch in the ON position, this alert indicator will light when the glow plugs are activated. The operator should wait until this light is no longer illuminated before starting the machine. Refer to Operation and Maintenance Manual, “Engine Starting” for more information about the glow plug starting aid.**

i07742538

## Product Link

**SMCS Code:** 7606

**S/N:** AS21–Up

**S/N:** HR21–Up

**S/N:** CD31–Up

**S/N:** KB31–Up

**S/N:** SNA1–Up

**S/N:** MWD1–Up

**S/N:** A9H1–Up

**S/N:** B7H1–Up

**S/N:** PWK1–Up

**S/N:** TNK1–Up

**S/N:** TSL1–Up

**S/N:** JXM1–Up

**S/N:** DSN1–Up

**S/N:** SRS1–Up

**S/N:** DXZ1–Up

**S/N:** YYZ1–Up

**Note:** Your machine may be equipped with the Cat® Product Link™ system.

The Cat Product Link communication device utilizes cellular and/or satellite technology to communicate equipment information. This information is communicated to Caterpillar, Cat dealers, and Caterpillar customers. The Cat Product Link communication device uses Global Positioning System (GPS) satellite receivers.

The capability of two-way communication between the equipment and a remote user is available with the Cat Product Link communication device. The remote user can be a dealer or a customer.

## Data Broadcasts

Data concerning this machine, the condition of the machine, and the operation of the machine is being transmitted by Cat Product Link to Caterpillar and/or Cat dealers. The data is used to serve the customer better and to improve upon Cat products and services. The information transmitted may include: machine serial number, machine location, and operational data, including but not limited to: fault codes, emissions data, fuel usage, service meter hours, software, and hardware version numbers and installed attachments.

Caterpillar and/or Cat dealers may use this information for various purposes. Refer to the following list for possible uses:

- Providing services to the customer and/or the machine
- Checking or maintaining Cat Product Link equipment
- Monitoring the health of the machine or performance
- Helping maintain the machine and/or improve the efficiency of the machine
- Evaluating or improving Cat products and services
- Complying with legal requirements and valid court orders
- Performing market research
- Offering the customer new products and services

Caterpillar may share some or all the collected information with Caterpillar affiliated companies, dealers, and authorized representatives. Caterpillar will not sell or rent collected information to any other third party and will exercise reasonable efforts to keep the information secure. Caterpillar recognizes and respects customer privacy. For more information, please contact your local Cat dealer.

## Operation in a Blast Site for Product Link Radios

### WARNING

**This equipment is equipped with a Cat® Product Link communication device. When electric detonators are being used for blasting operations, radio frequency devices can cause interference with electric detonators for blasting operations which can result in serious injury or death. The Product Link communication device should be deactivated within the distance mandated under all applicable national or local regulatory requirements. In the absence of any regulatory requirements Caterpillar recommends the end user perform their own risk assessment to determine safe operating distance.**

Refer to your products Operation and Maintenance Manual Supplement, “Regulatory Compliance Information” for more information.

For information regarding the methods to disable the Cat Product Link communication device, please refer to your specific Cat Product Link manual listed below:

- Operation and Maintenance Manual, SEBU8142, “Product Link - PL121, PL321, PL522, and PL523”
- Operation and Maintenance Manual, SEBU8832, “Product Link PLE702, PLE602, PLE601, PL641, PL631, PL542, PL240, PL241, PL141, PL131, PL161, and PL042 Systems”

**Note:** If no radio disable switch is installed and the equipment will be operating near a blast zone, a Product Link radio disable switch may be installed on the equipment. The switch will allow the Cat Product Link communication device to be shut off by the operator from the equipment control panel. For more details and installation procedures, refer to the following:

- Special Instruction, REHS7339, “Installation Procedure for Product Link PLE640 Systems”
- Special Instruction, REHS8850, “Installation Procedure for the Elite Product Link PLE601, PLE641, and PLE631 Systems”
- Special Instruction, SEHS0377, “Installation Procedure for the Product Link PL131, PL141, and PL161 Systems”

- Special Instruction, REHS9111, “Installation Procedure for the Pro Product Link PL641 and PL631 Systems”

i02879748

## Machine Security System

SMCS Code: 7631

### Machine Security System (If Equipped)

#### NOTICE

If equipped with a Caterpillar Machine Security System (MSS), this machine may not start under certain conditions. Read the following information and know your machine's settings. Your Caterpillar dealer can identify your machine settings.



**Machine Security System (MSS) – Machines that are equipped with a Caterpillar Machine Security System (MSS) can be identified by a decal in the operator station. MSS is designed to prevent theft of the machine or unauthorized operation.**

### Basic Operation

MSS may be programmed to read a standard Caterpillar key or an electronic key. The electronic key contains an electronic chip within the plastic housing for the key. Each key emits a unique signal to the MSS. The keys can be identified by a gray housing or a yellow housing. MSS can have programmed settings to require an electronic key or a standard Caterpillar key for starting during certain periods of time.

When the key start switch of the machine is turned to the ON position, the ECM will read the unique ID that is stored in the electronic key. The ECM will then compare this ID to the list of authorized keys. The following table tells the operator the status for starting the machine. The status light is located near the key start switch.

Table 25

|           |                            |
|-----------|----------------------------|
| Red light | The key is not authorized. |
|-----------|----------------------------|

**Note:** MSS will not shut down the machine after the machine has started.

### Security Management

The MSS has the capability to allow you to program the system to automatically activate at different time periods with different keys. The MSS can also be programmed to reject a specific electronic key after a selected date and time. When you turn the key to the OFF position and the MSS is active, you have a 30 second interval in order to restart the machine with an unauthorized key. Also if the machine stalls, there is a 30 second interval for restarting the machine. This 30 second interval is counted from the time of turning the key to the OFF position.

**Note:** Know your machine's settings because the use of an electronic key is no guarantee that the machine can be restarted.

An expiration date can be set for each electronic key that is contained in the list of keys for the machine. The key will no longer start the machine when the internal clock in the security system passes the expiration date. Each entry in the list of keys can have a different expiration date.

Spare keys are available from your dealer. Before a key can operate the machine, the MSS must be set to accept that particular key. Contact your Caterpillar dealer for information on additional features of the MSS.

# Engine Starting

i03879237

## Engine Starting

SMCS Code: 1000; 7000

### WARNING

**Do not use aerosol types of starting aids such as ether. Such use could result in an explosion and personal injury.**

It is important to prepare the machine for operation in temperatures that are below 0 °C (32 °F). It is also important to follow the appropriate warm up procedures when the machine is operated in temperatures that are below 0 °C (32 °F).

Machine preparation for cold weather includes using the correct hydraulic system oil. The factory fills the hydraulic system with 10W hydraulic oil which has a minimum operating temperature of -20 °C (-4 °F). If the machine will be operated at temperatures below -20 °C (-4 °F), the 10W oil must be replaced with 0W30 hydraulic oil in order to provide the proper oil viscosity. Refer to Operation and Maintenance Manual, "Lubricant Viscosities and Refill Capacities". Refer to Operation and Maintenance Manual, SEBU5898, "Cold Weather Recommendations for Caterpillar Machines". Refer to Operation and Maintenance Manual, SEBU6250, "Caterpillar Machine Fluids Recommendations".

#### NOTICE

Keep the engine speed low until the engine oil pressure alert indicator goes out. If the alert indicator does not go out within ten seconds, stop the engine and investigate the cause before starting again. Failure to do so can cause engine damage.

#### NOTICE

If the engine does not start within 30 seconds, disengage the starter. Wait for 2 minutes and repeat the procedure.

#### NOTICE

If you fail to follow the steps described below, damage to the engine or damage to the hydraulic system may occur.

1. Fasten the seat belt.
2. Pull the armrests downward.

3. Before the engine is started, check for the presence of bystanders or maintenance personnel. Ensure that all personnel are clear of the machine. Briefly sound the forward horn before you start the engine.
4. Move the governor control lever or the accelerator pedal to low idle.
5. Turn the engine start switch key to the ON position. If the glow plug indicator light is ON, wait until the light goes out. Then turn the key to the START position. After the engine starts, the glow plugs may continue to operate briefly, even though the light is off. Release the key after the engine has started.
6. Disengage the parking brake.
7. Run the engine for 5 minutes before performing the following procedure. Run the engine at half throttle. Hold the work tool joystick control in the TILT BACK position for thirty seconds. Release the control for thirty seconds. Hold the work tool joystick control in the DUMP position for thirty seconds. Release the control for thirty seconds. Perform the procedure for three minutes.

**Note:** If you are operating the machine below 0 °C (32 °F), perform the procedure for eight minutes.

#### NOTICE

Do not use the hydraulic interlock override function to warm up the machine.

8. Keep all personnel away from the machine. Move the machine very slowly to an open area. Repeat Step 7 as you move the machine back and forth for 3 m (10 ft).

**Note:** More warm up time may be required if the hydraulic functions are sluggish.

# Operation

i03879242

## Operation Information

**SMCS Code:** 7000

### General Information

1. Adjust the operator's seat.
2. Fasten the seat belt.
3. Lower the armrests.
4. Start the engine and allow the machine to warm up. Refer to Operation and Maintenance Manual, "Engine Starting".
5. Disengage the parking brake.
6. Raise all lowered work tools and attachments in order to negotiate any obstacles.
7. Smoothly move the speed and direction control for the desired direction and speed.

To prevent injury, make sure that no people are working on the machine or near the machine. To prevent injury, keep the machine under control at all times.

Do not allow the machine to overspeed when you go downhill. Move the joystick toward the NEUTRAL position in order to reduce the speed of the machine when you are going downhill. For additional information, refer to "Operating on a Slope".

Always put the heaviest end of the machine uphill when you are working on an incline.

The loader arms of the machine should be fully lowered onto the stops when you are digging with the machine. Digging with the loader arms in the fully lowered position will transfer the stress that is placed on the loader arm into the frame.

---

#### NOTICE

The use of this machine in certain applications can cause premature wear and/or failure of the tracks. Applications that may cause premature wear and/or failure of the tracks include: use in rocky terrain, use in gravel, use in concrete demolition and use in terrain where metal debris is present.

Damage to the tracks that is caused from using the machine in these conditions is not covered under warranty.

---

Avoid any situation that causes the tracks of the machine to spin on the ground. Avoid spinning the tracks. This will extend the life of the track.

### Operating on a Slope

When it is necessary to travel across a slope, never exceed a slope that is greater than 3 to 1 (18.4°).

When it is possible, avoid operating the machine across a slope. When it is possible, operate the machine up a slope and down a slope. Never exceed a slope that is greater than 25 degrees for continuous fore/aft slope operation and 35 degrees intermittent fore/aft operation. The engine has an intermittent rating of 15 minutes. Do not turn the machine while you are operating on a slope.

---

#### NOTICE

When it is necessary to operate the machine on a slope, keep bucket loads light in order to decrease the possibility of derailing the tracks.

---



---

#### NOTICE

If the correct method for turning is not followed, the tracks may derail.

---

When it is necessary to travel across a slope, the following steps should always be followed:

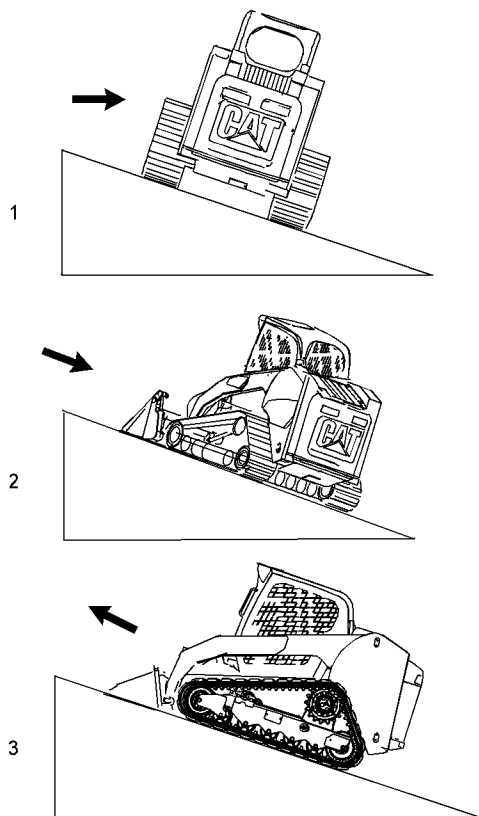

Illustration 95

g01451273

1. Stop the machine. Turn the machine slowly while you are backing down the slope.

**Note:** Do not back up a hill in order to turn.

2. Position the machine so that the front of the machine faces the direction for travel that is desired.

### Operating on a Transition

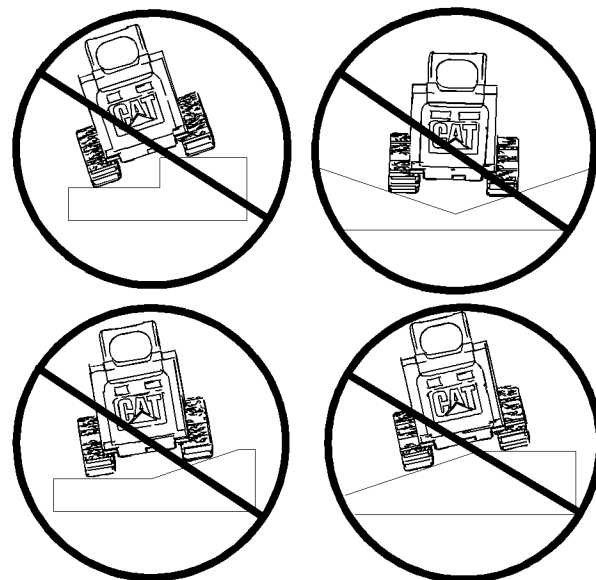

Illustration 96

g01296038

#### NOTICE

Avoid operating this machine on transitions. Operating this machine on transitions may cause the tracks to derail.

When the machine is operated on a transition, the tracks may not be supported fully.

When the tracks are not supported fully, the wheels may ride on top of the drive lugs of the tracks. The track will derail if you continue to travel on the transition.

If you must travel on a transition, travel the machine at 90° to the transition. Do not perform hard turns or fast turns when you are operating the machine on the transition.

## Counterrotate turn

For maximum life of the undercarriage, use more gradual turns while you slowly move forward or reverse. Gradual turns will help minimize wear on the track and wear on the wheels. Only use counterrotate turns, if necessary. Sharp turns will increase the wear on the components of the undercarriage.

i05301650

## Work Tool Coupler Operation

**SMCS Code:** 6129; 7000

### **WARNING**

**Improper Attachment of the Work Tool could result in injury or death.**

**Do not operate the machine without confirmation that the coupler pins are fully engaged. Follow the operating procedures in the Operation and Maintenance Manual.**

## Attaching the Work Tool

**Note:** Before you install the work tool, inspect the coupler and the work tool mounting bracket for any wear or for any damage. Ensure that the work tool mounting bracket and the face of the coupler are clean. Ensure that the coupler has no accumulation of material. Refer to Operation and Maintenance Manual, “Quick Coupler - Inspect” and Operation and Maintenance Manual, “Work Tool Mounting Bracket - Inspect” for inspection procedures.

1. Position the work tool on a level surface. Move the hydraulic lines (if equipped) for the work tool and electrical lines (if equipped) away from the work tool mounting bracket.

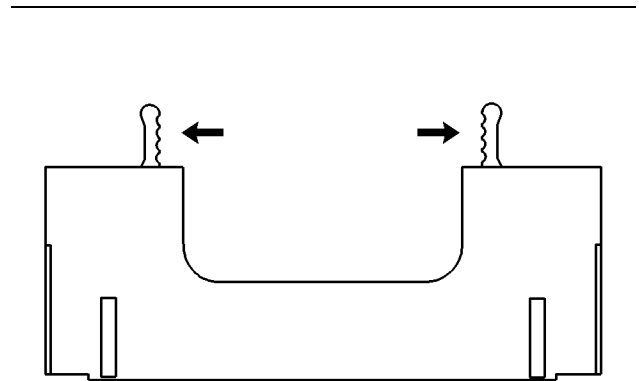

Illustration 97

g00929776

2. If the machine is equipped with a manual coupler, ensure that the levers for the coupler are in the DISENGAGED position. If the machine is equipped with a hydraulic quick coupler, refer to Operation and Maintenance Manual, “Operator Controls” for details on the location and the operation of the hydraulic quick coupler control.
3. Enter the machine.
4. Fasten the seat belt and lower the armrest.
5. Start the engine.
6. Disengage the parking brake.
7. Tilt the quick coupler assembly forward.

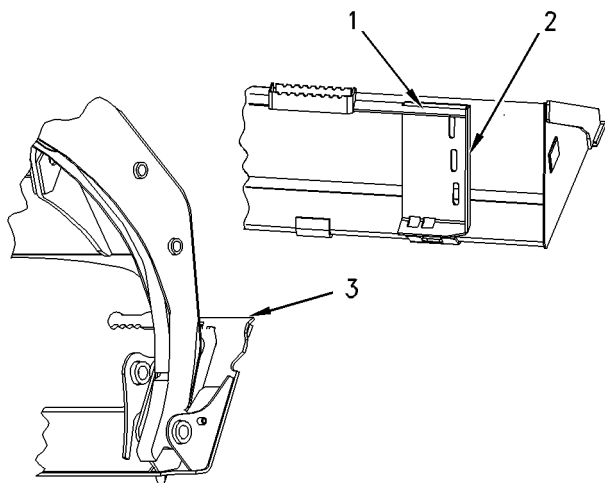

Illustration 98

g00929878

8. Align the quick coupler assembly (3) between the outer plates (2) of the mounting bracket. Move the quick coupler assembly under the angled plate (1) of the mounting bracket and rack back the work tool.

9. Fully lower the loader arms.

**⚠ WARNING**

Improper attachment of the work tool could result in injury or death. If the work tool touches the ground, the work tool may move away from the coupler. Do not allow the work tool to touch the ground until the coupler pins are fully engaged.

10. Turn the engine start switch key to the OFF position in order to stop the engine.

11. If the work tool requires hydraulics, the hydraulic system pressure must be released before you connect the work tool. Refer to the section "Releasing the Auxiliary Hydraulic System Pressure".

12. Exit the machine.

**Note:** If you are installing a material handling arm that is not equipped with the optional center step, do not exit the machine. A second person needs to perform steps 13 through step 15.

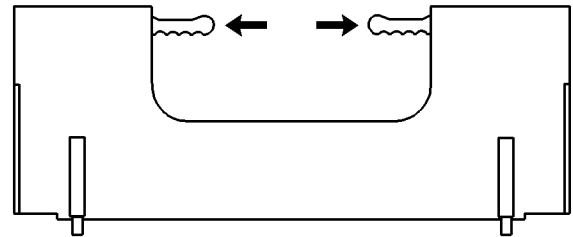

Illustration 99

g00929831

13. Engage the coupler pins. If the machine is equipped with a manual coupler, ensure that the levers for the coupler are in the ENGAGED position. If the machine is equipped with a hydraulic quick coupler, refer to Operation and Maintenance Manual, "Operator Controls" for details on engaging the coupler pins.

14. If the work tool requires hydraulics, refer to the following procedure in order to connect the hydraulic hoses.

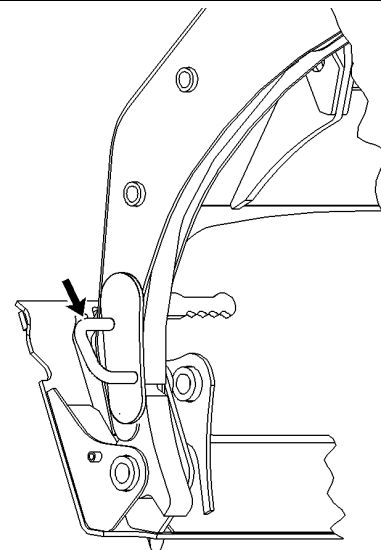

Illustration 100

g00929874

a. Route the hydraulic hoses through the hose guide on the machine in order to prevent damage to the hoses. Not all work tools require the hydraulic hoses to be routed through the hose guide. The work tool Operation and Maintenance Manual will inform you if the hydraulic hoses need to be routed through the

Operation Section  
Work Tool Coupler Operation

hose guide. Caterpillar work tools require the hoses to be routed through the hose guide.

- b. Ensure that the quick connect couplers are clean.
- c. Connect the auxiliary hydraulic hoses for the work tool to the machine. Twist the collar of the quick connect coupler for one quarter of a turn in order to secure the hydraulic connections. If the work tool uses High Flow hydraulics, refer to Operation and Maintenance Manual, "Joystick and Auxiliary Hydraulic Controls" for operating details.

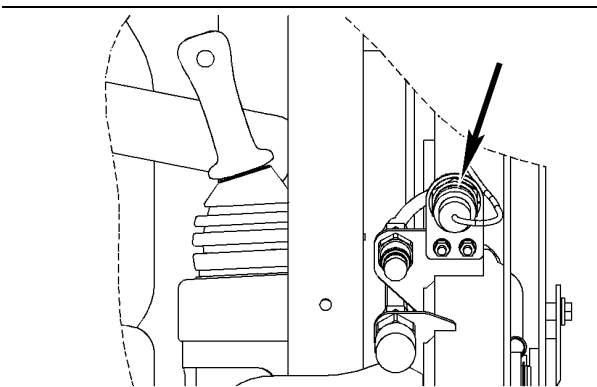

Illustration 101

g01074445

Standard Auxiliary Connection

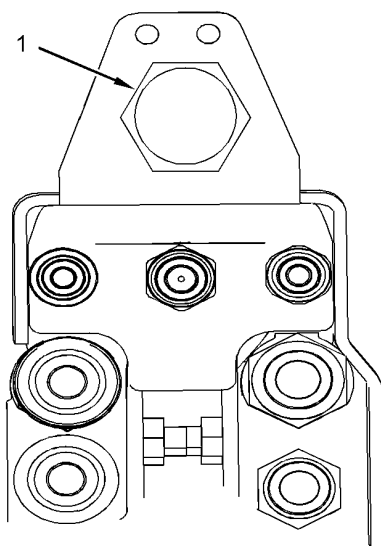

Illustration 102

g01109579

High Flow option (Early model 226B3)

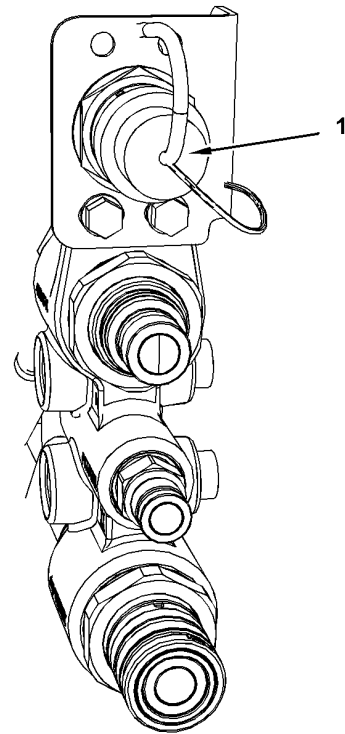

Illustration 103

g02571199

High Flow option (Later models)

- d. If the work tool is equipped with electrical lines, then route the electrical lines with the hydraulic hoses and connect the wire harness to the electrical connector (1) on the host machine. Check the connections in order to ensure that the connections are properly secured. Check the connections on the work tool in order to ensure that the connections are in the correct receptacle.

**Note:** If your High Flow work tool does not have a wiring harness, a Jumper Plug should be installed on the electrical plug (1) for the work tool control. Without this Jumper Plug, the machine will not provide high flow to the work tool. Refer to your Parts Manual for the current part number for the Jumper Plug.

- e. If the work tool is equipped with a water line, then connect the water line from the work tool to the connector on the machine. Move the water line to a position that is away from the work tool mounting bracket.

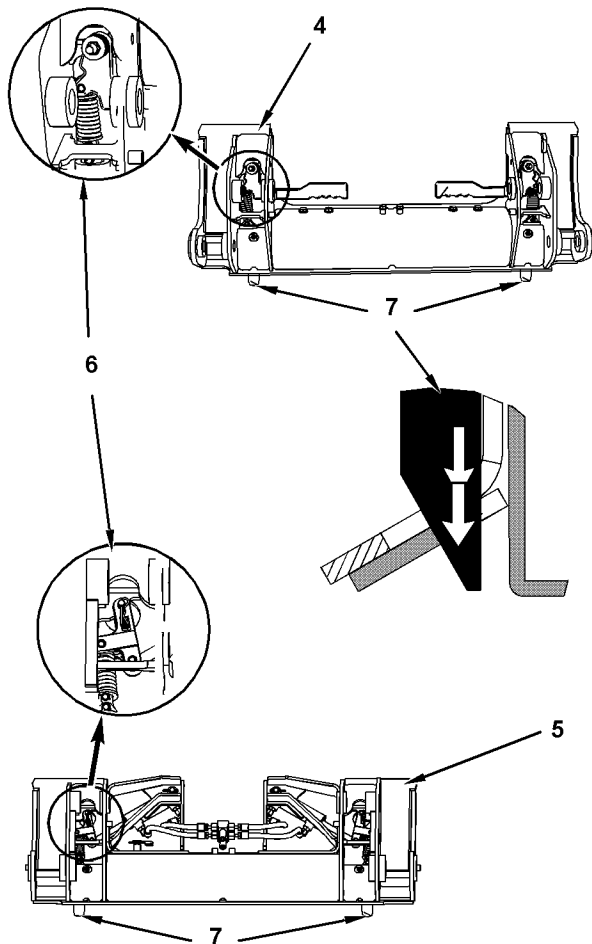

Illustration 104

g01352344

- (4) Manual Work Tool Coupler  
 (5) Hydraulic Work Tool Coupler  
 (6) Lever for the Coupler Pin  
 (7) Coupler Pins

15. Visually ensure that both coupler pins (7) are extending out of the holes in the work tool mounting bracket.
16. Use the following procedure to verify engagement of the coupler pins.
  - a. Enter the machine.
  - b. Fasten the seat belt and lower the armrests.
  - c. Start the engine.
  - d. Disengage the parking brake.
  - e. Raise the work tool off the ground.
  - f. Visually inspect the coupler pins (7) in order to ensure that the pins are fully extended through the work tool.

- g. Visually inspect the lever (6) that holds the coupler pins in order to ensure that the lever is in the proper position.

- h. Activate the tilt control in order to tilt the work tool downward.

- i. Apply down pressure on the work tool.

**Note:** The work tool Operation and Maintenance Manual will inform you if forward pressure should not be applied on a work tool.

- j. Move the machine backward. Ensure that the coupler pins do not disengage from the work tool.

17. Test the work tool for leaks and for proper operation.

## Removing the Work Tool

### **⚠ WARNING**

Disengaging the coupler pins will release the work tool from control of the operator.

Serious injury or death may result from disengaging the work tool when it is in an unstable position or carrying a load.

Place the work tool in a safe position before disengaging the coupler pins.

### **⚠ WARNING**

Inadvertent movement of the work tool may occur if the coupler pins are disengaged before the auxiliary hose lines are disconnected.

Serious injury or death may result from disengaging the coupler pins before the auxiliary hose lines are disconnected.

Place the work tool in a safe position and disconnect the auxiliary hose lines before disengaging the coupler pins.

### NOTICE

Pulling the work tool with the auxiliary hoses could result in damage to the host machine or the work tool.

1. Position the machine on level ground.
2. Lower the work tool to the ground.
3. Rack back the work tool until the work tool is slightly off the ground.

**Note:** If the machine is equipped with a manual coupler, do not fully rack back the couple. This will allow proper clearance to the lift arms with the handles in the fully DISENGAGED position.

4. Turn the engine start switch key to the OFF position in order to stop the engine.
5. If the work tool requires hydraulics, the hydraulic system pressure must be released. Refer to the section “Releasing the Auxiliary Hydraulic System Pressure”.
6. Perform Step 7 through Step 12 only after you have released the hydraulic system pressure.
7. Disconnect the auxiliary hydraulic hoses from the machine.

**Note:** If protective caps are available, install protective caps over the quick connect couplers.

8. If hoses are routed through the hose guide, remove the hoses from the hose guide. Move the hoses to a position that is away from the work tool mounting bracket.

**Note:** Connect the hoses for the work tool together. Connecting the hoses together will reduce the probability of contaminating the hydraulic system. Connecting the hoses together will reduce the buildup of pressure in the hoses. Connecting the hoses together will ease the connection of the hoses to the machine.

9. If the work tool is equipped with an electrical line, then disconnect the wire harness from the connector on the machine. If protective caps are available, install protective caps over the electrical connectors.
10. If the auxiliary electrical line is routed through the hose guide, remove the line from the hose guide. Move the auxiliary electrical line to a position that is away from the work tool mounting bracket.
11. If the work tool is equipped with a water line, then disconnect the water line from the connector on the machine. Move the water line to a position that is away from the work tool mounting bracket.
12. Exit the machine.

**Note:** If you are removing a material handling arm that is not equipped with an optional center step, do not exit the machine. A second person needs to perform step 13.

13. Disengage the coupler pins. If the machine is equipped with a manual coupler, ensure that the levers for the coupler are in the DISENGAGED position. If the machine is equipped with a hydraulic quick coupler, refer to Operation and Maintenance Manual, “Operator Controls” for details on disengaging the coupler pins with the hydraulic quick coupler control.

14. Enter the machine.
15. Fasten the seat belt and lower the armrest.
16. Start the engine.
17. Disengage the parking brake.
18. As you slowly back away from the mounting bracket, tilt the quick coupler assembly forward until the top of the quick coupler assembly clears the angled plate.
19. Back away from the work tool.

## Releasing the Auxiliary Hydraulic System Pressure

### NOTICE

If the work tool is equipped with an Operation and Maintenance Manual, follow the procedure that is described in the Operation and Maintenance Manual for that work tool. Damage to the work tool and the host machine may occur if you do not follow the proper installation procedure.

Refer to Operation and Maintenance Manual, “Operator Controls : Auxiliary Hydraulic Pressure Release”.

## Standard Flow Auxiliary Circuit and the High Flow Auxiliary Circuit (if equipped)

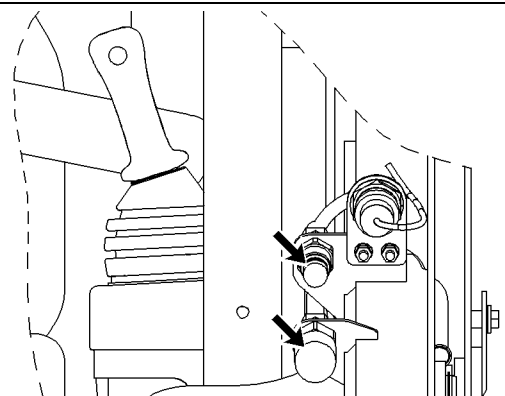

Illustration 105

g00902862

Auxiliary quick connectors

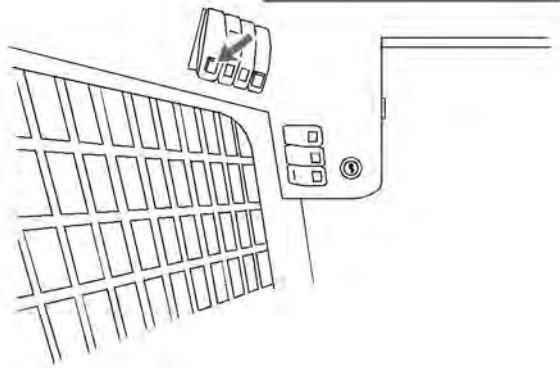

Illustration 106

g01016223

### Auxiliary Hydraulic Pressure Release

1. Stop the engine.
2. Move the engine start switch to the ON position and release the parking brake.
3. Push up on the locking tab and press the bottom of the switch in order to release the pressure in the Standard Flow Auxiliary Circuit and the High Flow Auxiliary Circuit (if equipped). Hold the switch for 4 seconds and release the switch.

**Note:** The pressure in the secondary circuit is not affected by this switch.

**Note:** The operator must remain in the seat with the armrest in the LOWERED position in order for the control to function.

4. Move the engine start switch to the OFF position.

### Secondary Auxiliary Circuit

The pressure in the secondary circuit is released with the following procedure:

If electrical power is available and the accumulator is charged, the pressure can be released from the operator station with the work tool control.

1. Fasten the seat belt. Lower the armrest.
2. Turn the engine start switch key to the ON position.
3. Release the parking brake.
4. Activate the controls for the secondary auxiliary function. Activate the controls several times in order to release all the pressure. Refer to Operation and Maintenance Manual, "Auxiliary Hydraulic Controls" for information about the controls.

If the pressure is not released, the accumulator is not charged. Recharge the accumulator by running the engine or cranking the engine for 15 seconds.

### Connecting under pressure 226B3, 242B3, 257B3, and 259B3 Later Models

Push the attaching Quick Disconnects together and hold for 5 seconds. Any pressure in the lines will be released, and the couplers can be connected.

### Disconnecting under pressure 226B3, 242B3, 257B3, and 259B3 Later Models

Push the attached Quick Disconnects together and hold for 5 seconds. Any pressure in the lines will be released, and the couplers can be separated.

i07695485

## Material Handling Arm Operation

SMCS Code: 6542; 6700; 7000

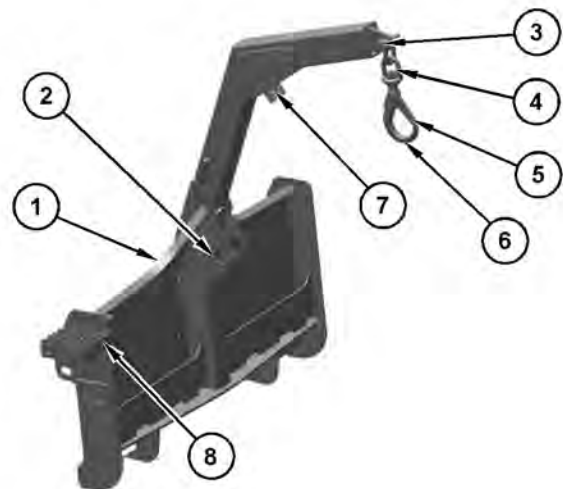

Illustration 107

g06397626

- (1) Location of Optional Center Step
- (2) Tie-Down Point
- (3) Lifting Point 2
- (4) Shackle
- (5) Hook Clasp
- (6) Hook
- (7) Lifting Point 1
- (8) Stored location of Position Lock Pin

Inspect the material handling arm and the attachments for wear and damage. Ensure that the load is properly attached to the material handling arm before you operate the machine.

**Note:** The physical size and the weight of the load determines the lifting point that is appropriate. Whenever it is possible, use the lifting point 1. This will improve the stability and this will reduce the movement of the load. Refer to the Operation and Maintenance Manual, "Material Handling Arm Rated Load" for the limitations on the weight.

**Note:** Use only Caterpillar 9V - 2714 Hook and Caterpillar 9V - 2715 Shackle to attach a load to the material handling arm. Never use an open hook. Use a line that is rated for 2.5 times the weight of the load.

### WARNING

**Do not allow anyone to be near a suspended load unless the position lock pin is installed. If the lift arms must be raised to handle a tall load, do not allow anyone to be near the suspended load unless the lift arms are blocked. Failure to follow the instructions or heed the warnings could result in injury or death.**

## Two Person Operation

### Attaching A Load

1. Verify that the load does not exceed the weight limit. Refer to the Operation and Maintenance Manual, "Material Handling Arm Rated Load" for the rated load capacities.
2. Keep all personnel out of the work area at all times, except when you are attaching or removing a load.
3. Enter the machine. Start the engine.
4. Disengage the parking brake.
5. Keep the loader arms in the fully lowered position. Slowly position the material handling arm until either lifting point 1 or the lifting point 2 is directly above the load.
6. Tilt the material handling arm forward until the hook is slightly higher than the load in order to minimize swinging of the load.
7. Stop the engine.
8. Wait as the second person attaches the load securely to the hook. The second person needs to ensure that the hook clasp is in the locked position.
9. Ensure that ALL personnel have left the work area.
10. Start the engine.
11. Disengage the parking brake.
12. Slowly tilt back the material handling arm until the material handling arm is fully tilted back.
13. Stop the engine.

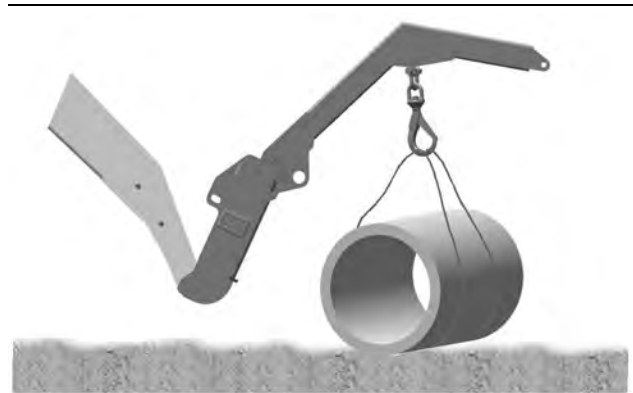

Illustration 108

g06399845



Illustration 109

g06399849

14. Wait as the second person installs the position lock pin through the hole in the material handling arm and the hole in the loader arm of the machine.

**Note:** This will prevent the material handling arm from tilting forward.

15. Wait as the second person secures the load to the tie-down points with a suitable line in order to minimize load swing.

**Note:** Do not move the load when you are securing the load. Do not pull the load toward the material handling arm when you are securing the load to the tie-down points.

16. Wait as the second person removes the position lock pin. Wait as the second person places the pin in the STORED position on the material handling arm.

### Removing a Load

1. Slowly tilt back the material handling arm until the material handling arm is fully tilted back. Lower the loader arms fully.
2. Stop the engine.
3. Wait as the second person installs the position lock pin through the hole in the material handling arm and the hole in the loader arm of the machine.
4. Wait as the second person removes the line that secures the load to the tie-down points.

5. Wait as the second person removes the position lock pin. Wait as the second person places the pin in the STORED position on the material handling arm.
6. Remove all personnel from the work area.
7. Start the engine.
8. Disengage the parking brake.
9. Lower the load to the ground.
10. Stop the engine.
11. Wait as the second person removes the load from the hook.
12. Remove all personnel from the work area.
13. Start the engine.
14. Disengage the parking brake.
15. Slowly tilt back the material handling arm until the material handling arm is fully tilted back.
16. Back away from the load.

### One Person Operation

**Note:** The material handling arm must be equipped with a center step in order to do the one person operation.

### Attaching the Load

1. Verify that the load does not exceed the weight limit. Refer to the Operation and Maintenance Manual, "Material Handling Arm Rated Load" for the rated load capacities.
2. Keep all personnel out of the work area at all times, except when you are attaching or removing a load.
3. Enter the machine. Start the engine.
4. Disengage the parking brake.

Operation Section  
Material Handling Arm Operation

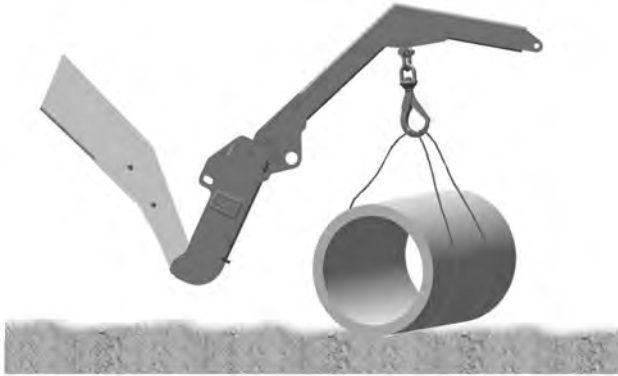

Illustration 110

g06399845

5. Keep the loader arms in the fully lowered position. Slowly position the material handling arm until either lifting point 1 or lifting point 2 is directly above the load.
6. Tilt the material handling arm forward until the hook is slightly higher than the load in order to minimize swinging of the load.
7. Stop the engine. Exit the machine.
8. Attach the load securely to the hook. Ensure that the hook clasp is in the LOCKED position.
9. Keep all personnel out of the work area.
10. Enter the machine. Start the engine.
11. Disengage the parking brake.
12. Slowly tilt back the material handling arm until the material handling arm is fully tilted back.
13. Stop the engine. Exit the machine.



Illustration 111

g06399849

14. Install the position lock pin through the hole in the material handling arm and the hole in the loader arm of the machine.
  15. Secure the load to the tie-down points with a suitable line in order to minimize load swing.
- Note:** Do not move the load when you are securing the load. Do not pull the load toward the material handling arm when you are securing the load to the tie-down points.
16. Remove the position lock pin and place the pin in the STORED position on the material handling arm.

### Removing a Load

1. Fully tilt back the material handling arm. Fully lower the loader arms.
2. Stop the engine. Exit the machine.
3. Install the position lock pin through the hole in the loader arm of the machine.
4. Remove the line that secures the load to the tie-down points .
5. Remove the position lock pin and place the pin in the STORED position on the material handling arm.
6. Keep all personnel out of the work area.
7. Enter the machine. Start the engine.
8. Disengage the parking brake.

9. Lower the load to the ground.
  10. Stop the engine. Exit the machine.
- Note:** Make sure that the load is stable.
11. Remove the load from the hook.
  12. Keep all personnel out of the work area.
  13. Enter the machine. Start the engine.
  14. Disengage the parking brake.
  15. Slowly tilt back the material handling arm until the material handling arm is fully tilted back.
  16. Back away from the load.

### Traveling with a Load

1. Ensure that all personnel have left the work area.
2. Start the engine.
3. Disengage the parking brake.
4. Raise the load so that the load is slightly off of the ground.
5. Slowly travel to the destination. Keep the load as close to the ground as possible. Travel up slopes with the load uphill. Travel down slopes with the load uphill. Do not travel across slopes.

i07695491

## Pallet Forks Operation

**SMCS Code:** 6700; 7000

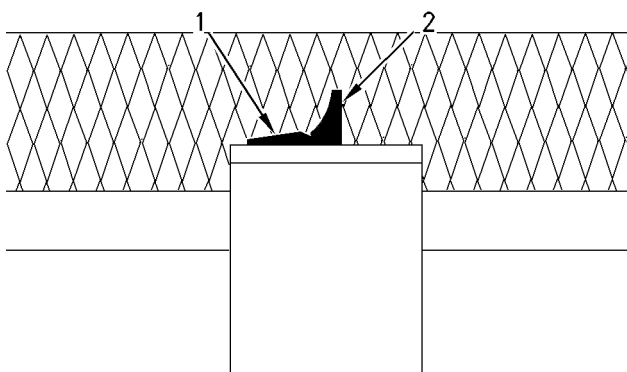

Illustration 112

g00955937

The "type 1" pin that is in the UNLOCKED position (2) and the LOCKED position (1).

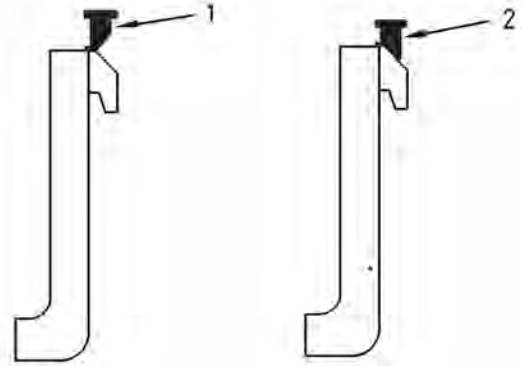

Illustration 113

g00955964

The "type 2" pin that is in the UNLOCKED position (1) and the LOCKED position (2).

1. Put the fork tines in the UNLOCKED position. Space the fork tines as far as possible from each other.
2. Put the fork tines in the LOCKED position.
3. Slowly, move the machine into position and engage the load. The machine should be square with the load. Space the forks evenly between the pallet stringers.
4. Move the machine forward until the load contacts the carriage.
5. Lift and lower the load carefully.
6. Carefully lower the load while you tilt the forks back to the travel position.

Travel with the load as low as possible while you still maintain ground clearance.

Travel with the load uphill on upgrades and on downgrades.

## Pallet Fork Tines Installation

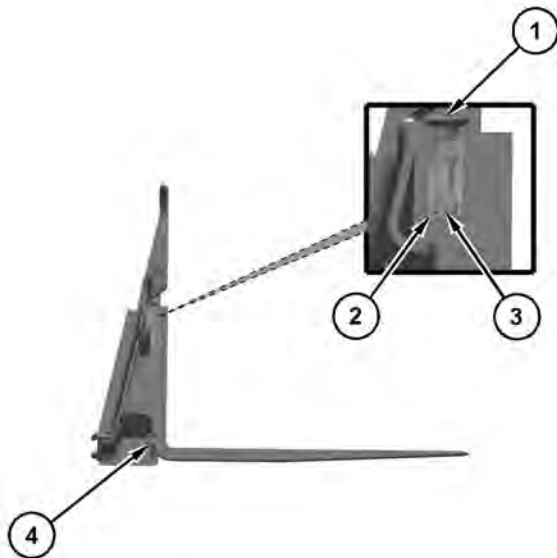

Illustration 114

g06397631

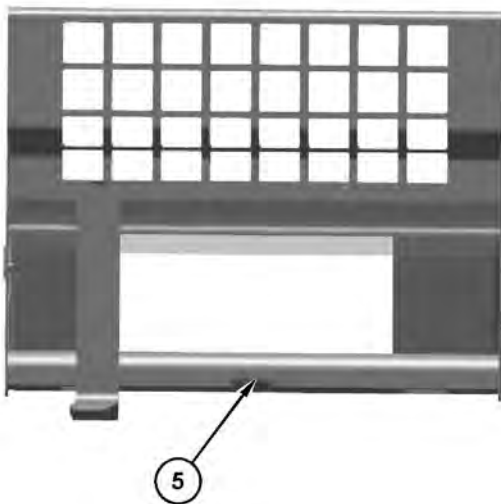

Illustration 115

g06397632

1. Place the lift arms fully down and adjust the coupler tilt until the front face of the fork carriage assembly is vertical.
2. On the tine, unlock the pin (1).
3. Assemble the tine at the center of the carriage by resting the top hook of the tine (2) on the upper carriage rail (3) and pass the bottom hook (4) through the clearance notch in the lower carriage rail (5). If the tine is touching the ground, raise the carriage slightly.
4. Move the tine to either side until the bottom hook contacts the lower carriage rail.
5. Move the tine to the desired position by applying side force, alternating between the top or bottom of the tine.
6. Once close to the desired position, lock the pin on the tine (1) and continue moving the tine until the pin locks down into one of the upper carriage rail notches.
7. Adjust the tine as needed to confirm it is in a vertical position from the front and side views.
8. Repeat steps 2-7 for the second tine.

i04399615

## Work Tool Operation

**SMCS Code:** 6700; 7000

**S/N:** AS21-Up

**S/N:** SNA1-Up

**S/N:** MWD1-Up

The following table describes the functionality of approved Cat work tools.

Refer to Operation and Maintenance Manual, "Joystick and Auxiliary Hydraulic Controls" for the location and operation of the joystick controls that are referenced below.

**Note:** All of the work tool functions that are described below are viewed as the operator seated in the machine.

Operate the machine and the work tool slowly in an open area. Check for proper operation of all controls and all protective devices on the machine and the work tool.

**Note:** During initial operation, unexpected motion may occur due to air in the hydraulic system. Cycle the hydraulic system approximately five times in order to purge air out of the circuit. You may need to add hydraulic oil to the machine after the machine fills the hydraulic circuits of the work tool. Refer to Operation and Maintenance Manual, "Hydraulic System Oil Level - Check" for the proper procedure for checking the hydraulic oil level.

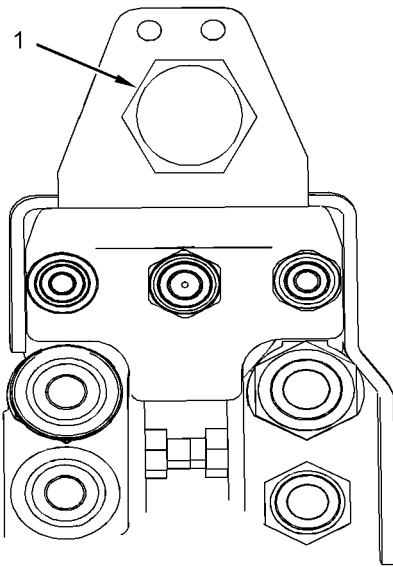

Illustration 116

g01109579

## High Flow Connections (Early models)

**Note:** If your High Flow work tool does not have a wiring harness, a Jumper Plug should be installed on the electrical plug (1) for the work tool control. Without this Jumper Plug, the machine will not provide High Flow to the work tool. Consult your Cat for the correct part number for your machine.

## Simple Hydromechanical Work Tools

Work tools in the following table are approved by Cat. Refer to Operation and Maintenance Manual, "Joystick and Auxiliary Hydraulic Controls" for the location and operation of the joystick controls that are referenced in the table.

Read the manual and understand the instructions and warnings in the Operation and Maintenance Manual for these work tools. Consult your Cat dealer for replacement manuals. Proper care is your responsibility.

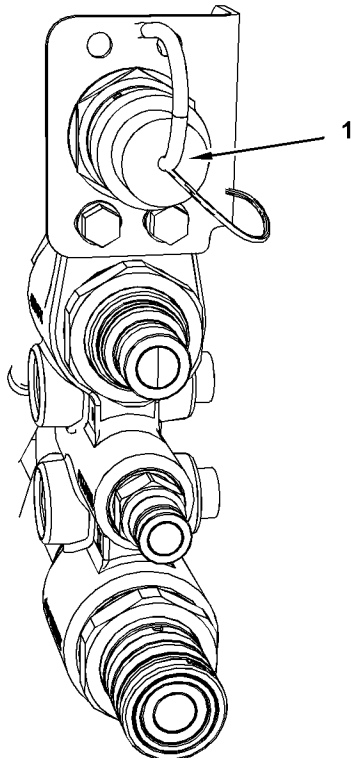

Illustration 117

g02571199

## High Flow Connections (Later models)

For all High Flow work tools, refer to Operation and Maintenance Manual, "Joystick and Auxiliary Hydraulic Controls". Connect the wiring harness to the electrical plug (1).

Table 26

| Operation of Cat Simple Hydromechanical Work Tools |                  |   |   |   |   |   |   |         |  |
|--|------------------|---|---|---|---|---|---|---------|--|
| Work Tool  | Joystick Control |   |   |   |   |   |   | Actions |  |
|  | A                | 5 | 6 | 1 | 2 | 3 | 4 |         | 7  |
| Multipurpose Bucket                                |                  |   |   | X |   |   |   |         | The bucket clam closes.  |
|  |                  |   |   |   | X |   |   |         | The bucket clam opens.   |
| All Grapple tools                                  |                  |   |   | X |   |   |   |         | The grapple closes.  |
|  |                  |   |   |   | X |   |   |         | The grapple opens.   |
| Angle Blade  |                  |   |   |   | X |   |   |         | The blade angles to the left.  |
|  |                  |   |   | X |   |   |   |         | The blade angles to the right.                                       |
| Dozer Blade  |                  |   |   |   | X |   |   |         | The blade angles to the left.  |
|  |                  |   |   | X |   |   |   |         | The blade angles to the right.                                       |
|  |                  | X |   |   | X |   |   |         | The blade tilts down to the left.                                    |
|  |                  | X |   | X |   |   |   |         | The blade tilts down to the right.                                   |
|  |                  |   | X |   | X |   |   |         | The blade tilts down to the left and the blade angles to the left.   |
|  |                  |   | X | X |   |   |   |         | The blade tilts down to the right and the blade angles to the right. |

Proper operation of the work tool is your responsibility. Do not use the work tool improperly.

Please follow the instructions that are listed below in order to use the grapple tools safely.

- Do not pry with one rake tine. Use multiple rake tines in order to loosen material.
- Remove the work tool from the machine before you lift the host machine. Refer to Operation and Maintenance Manual, "Lifting and Tying Down the Machine" for details.
- Do not place the weight of the host machine on the grapples in the open position.

## Complex Hydromechanical Work Tools

**Note: For the functionality of Cat Complex Work Tools, please read the Operation and Maintenance Manual for the work tool.**

Consult your Cat dealer for replacement manuals. Please read all the safety messages and understand all the safety messages for each work tool.

## Parking

i03879698

### Stopping the Engine

i02582658

**SMCS Code:** 1000; 7000

#### NOTICE

Stopping the engine immediately after it has been working under load, can result in overheating and accelerated wear of the engine components.

Refer to the following procedure, to allow the engine to cool, and to prevent excessive temperatures in the turbocharger housing (if equipped), which could cause oil coking problems.

1. Operate the engine for five minutes at low idle with no load.

**Note:** This allows hot areas in the engine to cool gradually. This will extend the engine life.

2. Move the joysticks to the NEUTRAL position.
3. Turn the engine start switch key to the OFF position.
4. Relieve the pressure in the auxiliary hydraulic system. Refer to Operation and Maintenance Manual, "Work Tool Coupler Operation" for details.
5. Ensure that the engine start switch key is in the OFF position after the pressure in the auxiliary hydraulic system has been relieved.
6. Cover the exhaust opening after the machine has cooled down.

### Stopping the Engine if an Electrical Malfunction Occurs

**SMCS Code:** 1000; 7000

#### Inside Cab

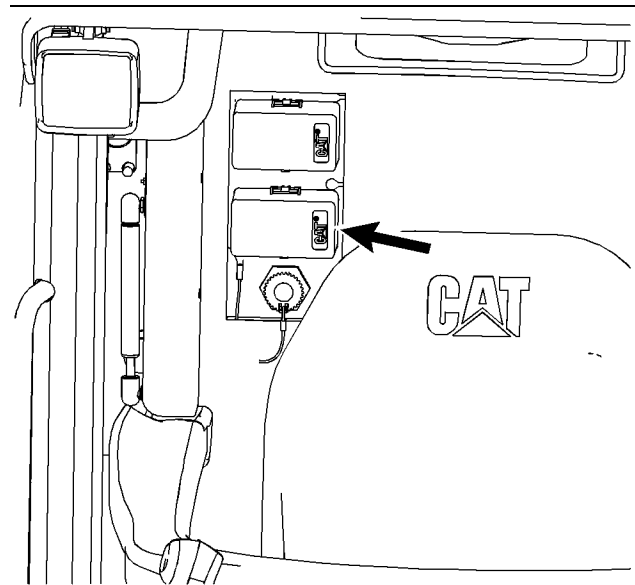

Illustration 118

g02144599

The fuse panel is located behind the seat on the right side.

Remove the cover in order to access the fuse panel.

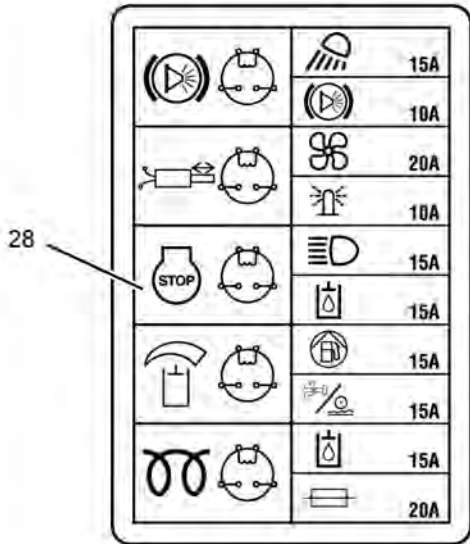

Illustration 119

g02142862

Remove the relay for the fuel shutoff solenoid (28) in order to shut off the fuel supply to the engine.

**Note:** Do not operate the machine until the malfunction has been corrected.

## Outside Cab

1. Lower the work tool to the ground.
2. Raise the armrest. Unfasten the seat belt. Exit the machine.
3. Open the engine access door. Refer to Operation and Maintenance Manual, "Access Doors and Covers".

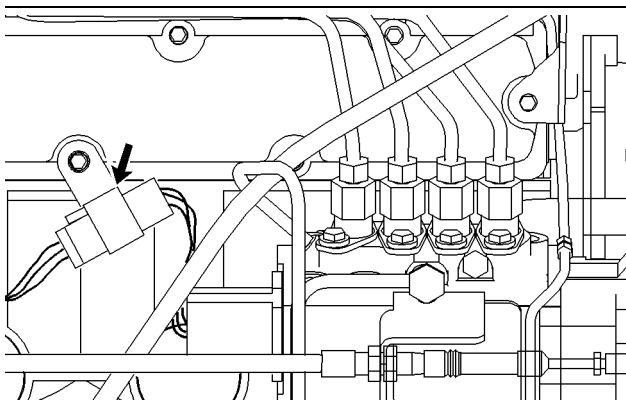

Illustration 120

g00953400

216B3, 226B3, and 247B3 Engine

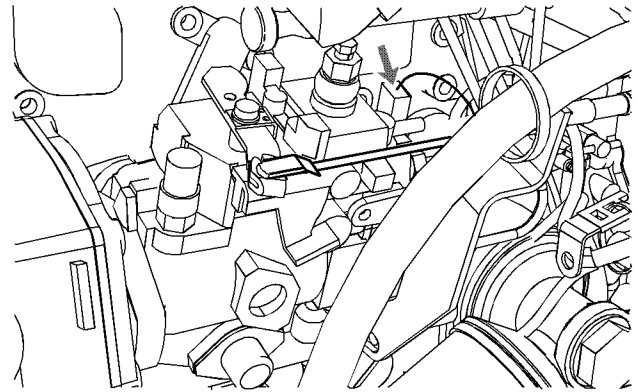

Illustration 121

g01017850

236B3, 242B3, 252B3, 257B3, and 259B3 Engine

4. Unplug the connector for the fuel shutoff solenoid.

**Note:** Do not operate the machine until the malfunction has been corrected.

i03879710

## Equipment Lowering with Engine Stopped

SMCS Code: 6700; 7000

### WARNING

Personal injury or death can result from a work tool falling.

Keep personnel away from the front of the machine when lowering the work tool.

Before lowering any equipment with the engine stopped, clear the area around the equipment of all personnel. The procedure will vary with the type of equipment that is lowered. Keep in mind that most systems use a high pressure fluid or air in order to raise or lower the equipment. The procedure will cause high pressure air, hydraulic fluid, or some other media to be released in order to lower the equipment. Wear appropriate personal protection equipment. Use the first procedure if the accumulator is charged. The second procedure is used if the accumulator is not charged.

## Lowering the Equipment with the Accumulator Charged

If electrical power is available and the accumulator is charged, the loader arms can be lowered from the operator station with the work tool control.

1. Fasten the seat belt. Lower the armrest.
2. Turn the engine start switch key to the ON position.

3. Push the parking brake switch.
4. Slowly move the work tool control to the LOWER position in order to slowly lower the loader arms.

If the loader arms do not lower, the accumulator is not charged. It is possible to recharge the accumulator by cranking the engine for a period of fifteen seconds. Repeat step 3 and step 4.

If there is no electrical power the loader arms must be lowered by using the procedure that is explained next.

## Alternate Lowering the Equipment

### **WARNING**

Personal injury can result from oil under high pressure.

**DO NOT** allow high pressure oil to contact skin.

**Wear appropriate protective equipment while working with high pressure oil systems.**

The loader arms must be lowered manually if the accumulator is not charged or if there is no electrical power.

Do not go under the raised lift arm without the brace for the loader lift arm in the LOCKED position. Use the alternate exit if the brace for the loader lift arm cannot be installed on raised lift arms.

**Note:** Make sure that there are no people near the front or sides of the machine.

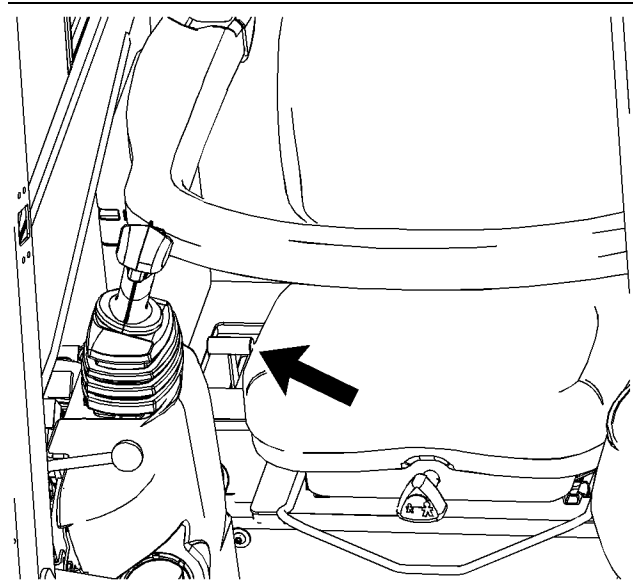

Illustration 122

g02141938

1. Push the handle rearward. Pull forward on the handle in order to stop the loader arms, if necessary.
2. Allow the loader arms to lower until the work tool is on the ground.
3. Pull forward on the handle in order to return the handle to the original position. Ensure that the handle is fully seated.
4. Make the necessary repairs before you operate the machine.

i03879719

## Leaving the Machine

**SMCS Code:** 7000

Refer to Operation and Maintenance Manual, "Parking" for details about stopping the engine and lowering the equipment.

The use of a wheel chock may be required when you leave the machine at the side of the road in Germany. The wheel chock is located next to the storage box in the cab.

The use of warning triangles may be required when you leave the machine at the side of the road in Germany.

i07735116

## **Machine Storage and Specified Storage Period**

**SMCS Code:** 7000

### **Machine Storage**

The Safety Section of this Operation and Maintenance Manual contains storage information for fuels, lubricants, and ether (if equipped).

The Operation Section of this Operation and Maintenance Manual contains information for short-term storage of this machine, including engine shutdown, parking, and instructions for leaving the machine.

For detailed steps on long-term storage refer to Special Instruction, SEHS9031, "Storage Procedure for Caterpillar Products".

### **Specified Storage Period**

The specified storage period of this machine is 1 year.

After the specified storage period has expired, consult your Cat dealer for inspect, repair, rebuild, install remanufactured, or install new components, and disposal options, and to establish a new specified storage period.

If a decision is made to remove the machine from service, refer to Decommissioning and Disposal for further information.

# Transportation Information

i07331340

## Shipping the Machine

**SMCS Code:** 7000

Investigate the travel route for overpass clearances. Make sure that there will be adequate clearance.

Before you load the machine and before you unload the machine remove ice, snow, or other slippery material from the loading dock and from the trailering surface. Removal of ice, snow, or other slippery material will help prevent the slipping of the machine as you load the machine. Removing ice, snow, or other slippery material will help prevent the machine from moving in transit.

---

### NOTICE

Obey all state and local laws governing the weight, width and length of a load.

Make sure the cooling system has proper antifreeze if moving machine to a colder climate.

Observe all regulations governing wide loads.

---

Do not use a fork lift to lift the machine. Using a fork lift to move your machine can result in property damage.

Choose the flattest ground when you load the machine or when you unload the machine.

---

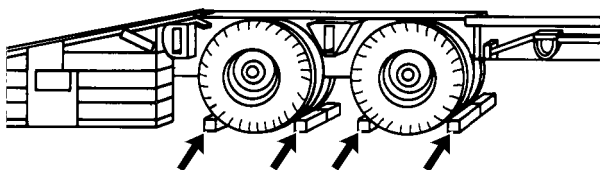

Illustration 123

g00040011

1. Before you load the machine, chock the trailer wheels or the rail car wheels. Before you unload the machine, chock the trailer wheels or the rail car wheels.

2. When you use loading ramps, make sure that the loading ramps have adequate length, adequate width, and adequate strength. In addition, make sure that the surface of the loading ramps is clean. This will help prevent the machine from sliding in all types of weather conditions. This will allow the machine to move on the ramps smoothly.
3. Maintain the slope of the loading ramps within 15 degrees of the ground.
4. Minimize any step between the base of the loading ramps and the ground.
5. Clean the tracks or tires on the machine to prevent any slippage.

## Loading the Machine

1. Position the machine so that the heaviest end of the machine is going up the ramps first.
2. Use caution when you travel over the areas around the loading ramp joints. Maintain the balance point of the machine. Keep the work tool low.
3. After you load the machine onto the trailer be sure that the machine is properly positioned on the trailer bed.
4. Lower the work tool to the floor of the transport vehicle.
5. Turn the engine start switch key to the OFF position to stop the engine.
6. Turn the engine start switch key to the ON position. Push the parking brake switch.
7. Move all joystick controls while you are pressing several times on each side of the auxiliary hydraulic control (if equipped) to relieve hydraulic pressure.
8. Move all hydraulic controls to the NEUTRAL position.
9. Turn the engine start switch key to the OFF position. Remove the engine start switch key.
10. Move the armrests to the RAISED position. Unfasten the seat belt.
11. Attach any vandalism protection.
12. Refer to the Operation and Maintenance Manual, "Lifting and Tying Down the Machine" for information on tying down the machine.

13. Cover the exhaust opening when the machine has cooled down.

## Unloading the Machine

1. Position the machine so that the machine can drive straight down the loading ramps. Position the machine so that the heaviest end of the machine goes down the ramps last.
2. Use caution when you travel over the areas around the loading ramp joints to maintain the balance point of the machine. Keep the work tool low.

i03879738

## Before Rooding the Machine

**SMCS Code:** 7000

Ensure that your machine has a work tool that is approved for rooding. See your Caterpillar dealer for work tools and for work tool attachments that are approved for rooding.

Complete all of the following operations that are applicable to your machine before you rood the machine.

### Brackets (Rear Lights)

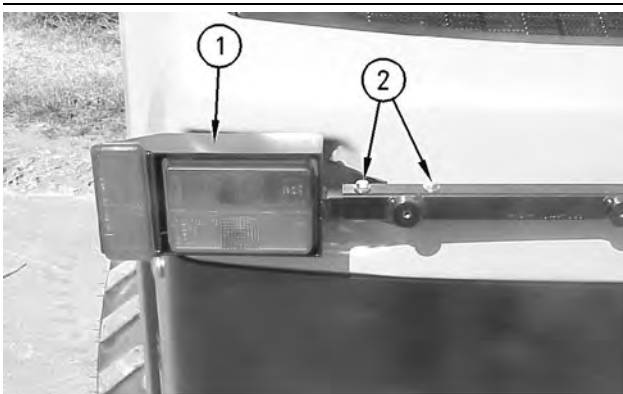

Illustration 124

g00713082

1. Remove the two bolts and washers (2).

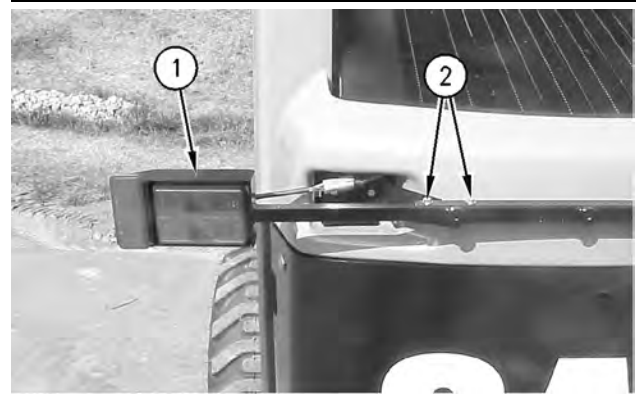

Illustration 125

g00713075

2. Move the tail light (1) to the EXTENDED position. Install the two bolts and washers (2).
3. Repeat step 1 through step 2 for the other rear light.
4. Verify that all lights are in proper working order.
5. Turn on the rooding lights when you are rooding the machine.

### First Aid Kit

If a first aid kit is required, see your Caterpillar dealer.

Ensure that the first aid kit contains the necessary supplies for emergency situations.

### Headlights

Refer to Operation and Maintenance Manual, "Headlights - Adjust" for the proper procedure to adjust the headlights.

### Hydraulic Shutoff

Disable the work tool control, the auxiliary hydraulic control (if equipped), and the high flow control (if equipped) when you are rooding the machine. Refer to Operation and Maintenance Manual, "Hydraulic Lockout and Interlock Override" for the procedure.

### Lift Arm

Perform the following procedure in order to place the lift arm and the work tool in the rooding position:

1. Enter the machine. Fasten the seat belt. Lower the armrest. Start the engine.
2. Disengage the parking brake.



Illustration 126

g00713528

3. Raise the lift arms so that the space between the frame and the right lift arm is approximately 30 mm (1.2 inch).
4. Stop the engine.

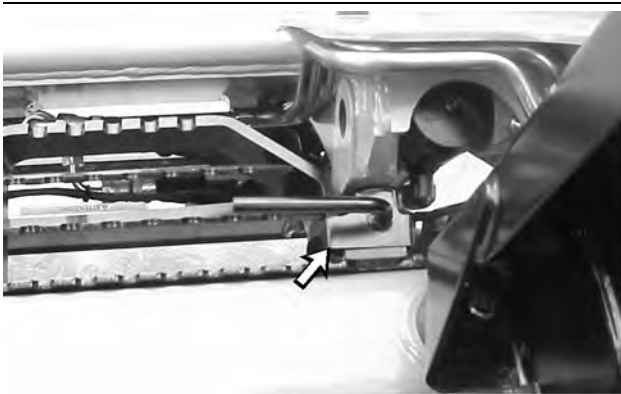

Illustration 127

g00713545

5. Insert the block for the lift arm between the frame and the right lift arm.
  6. Start the engine. Disengage the parking brake.
  7. Slowly lower the lift arms onto the block.
- Note:** The block for the lift arms is located in the storage box in the cab.
8. Fully tilt back the coupler. Stop the engine.
  9. Raise the armrest. Unfasten the seat belt. Exit the machine.

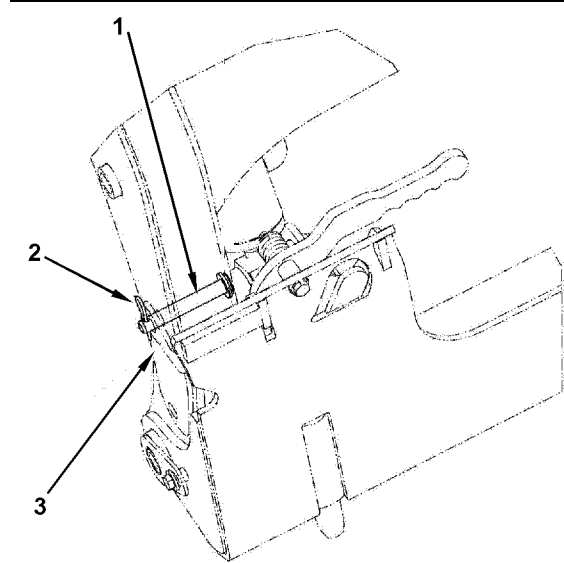

Illustration 128

g01087536

10. Insert the locking pin (1) for the coupler through the tab (3) on the coupler and through the hole in the lift arm.
11. Secure the locking pin (1) for the coupler with the cotter pin (2).

**NOTICE**

Do not tilt the coupler forward while the locking pin for the coupler is installed. Damage to the coupler may result.

**Note:** The locking pin for the coupler is located in the storage box in the cab.

**12.** Disable the hydraulics for the linkage while the locking pin for the coupler is installed. Disable the hydraulics for the linkage with the hydraulic shutoff control. Refer to Operation and Maintenance Manual, "Hydraulic Lockout and Interlock Override" for the procedure.

## Mirrors

Refer to the Operation and Maintenance Manual, "Mirrors" for the adjustment procedure for the mirrors.

## Portable Warning Light

In Germany, install the portable warning light on top of the cab.

## Rotating Beacon Light

In Italy, install the rotating beacon light on top of the cab. Insert the plug into the receptacle on the top rear of the cab.

## Slow Moving Vehicle Sign

If a slow moving vehicle sign is required, install a slow moving vehicle sign on the rear of the machine.

## Tires

Ensure that your machine has tires that are approved for rooding. Ensure that the tires have the proper pressure. See your Caterpillar dealer for approved tires for rooding.

## Traffic Regulations

Learn and obey all of the traffic regulations when you are rooding the machine.

## Work Lights

Turn off all work lights.

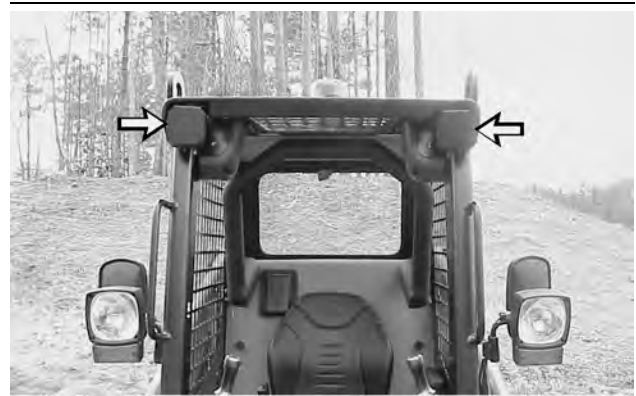

Illustration 129

g00715754

If equipped, install covers for the front work lights.



Illustration 130

g00715759

If equipped, install covers for the rear work lights.

## Prepare the Work Tool

### Angle Blade

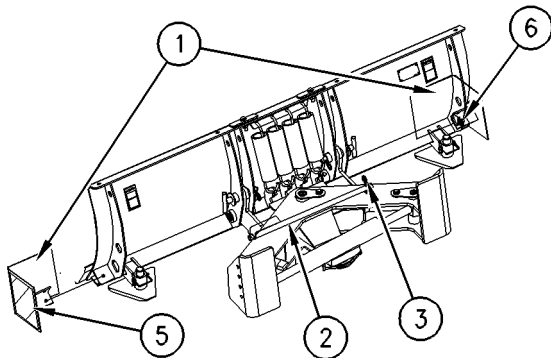

Illustration 131

g00718258

1. Ensure that all roading decals (5) are properly attached to the front and side of each of the guards (1) for the Angle Blade. There are a total of four decals for the Angle Blade.
2. Place the guard (1) on the lower corner of the blade so that the hole in the blade is aligned with the hole in the guard.
3. Install the bolt, two washers and the wing nut (6).
4. Repeat steps 2 and step 3 on the other end of the Angle Blade.
5. Install the articulation lock (2) for the angle blade. Install cotter pin (3) in the end of the articulation lock.

## Buckets

The guard for the buckets is used on both simple buckets and hydromechanical buckets.

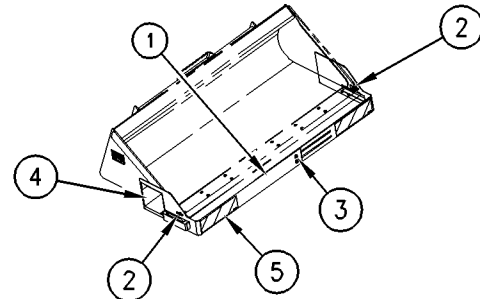

Illustration 132

g00715871

1. Make sure that the two front roading decals (5) are properly attached to the guard (1) for the bucket. Make sure that the side roading decals (4) are properly attached to the guard for the bucket. There are a total of four decals on the guard for the bucket.
2. Loosen the wing nuts (3) and move the guard for the bucket so that the guard fits over the outside edge of the bucket. Tighten the wing nuts.
3. Install the bolts, three washers, plates, and wing nuts (2) on both side plates of the bucket.

## Cold Planer

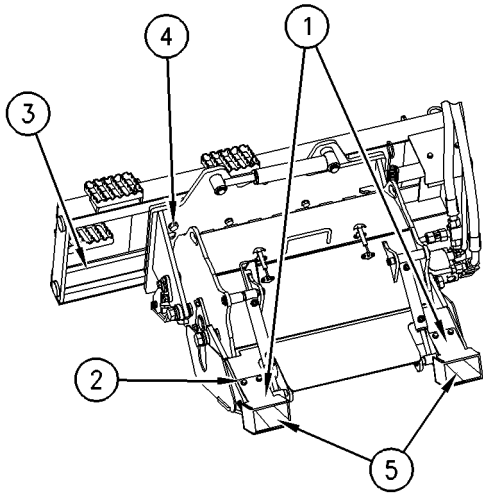

Illustration 133

g00715874

1. Ensure that all roading decals (5) are properly attached to both of the guards (1) for the Cold Planer. There are a total of two decals for the Cold Planer.
2. Place the guards (1) on the front skid pads so that the holes in the guards align with the holes in the Cold Planer. Install the bolts, washers and nuts (2).
3. Install the side shift lock (3) for the Cold Planer.
4. Install the pivot lock (4) for the Cold Planer.

## Landscape Rake

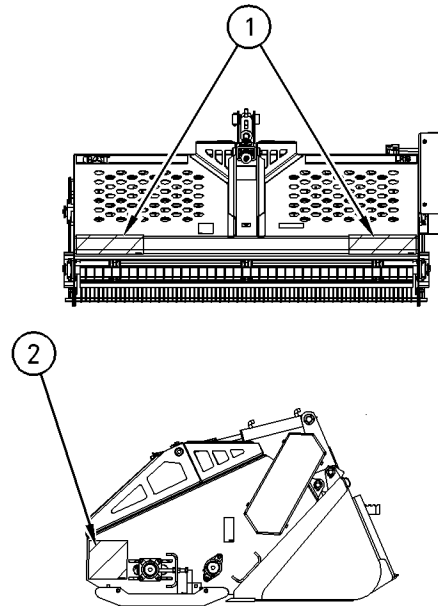

Illustration 134

g00715895

Ensure that the two front decals (1) are attached to the Landscape Rake. Ensure that the two side decals (2) are attached to the Landscape Rake.

## Pickup Broom

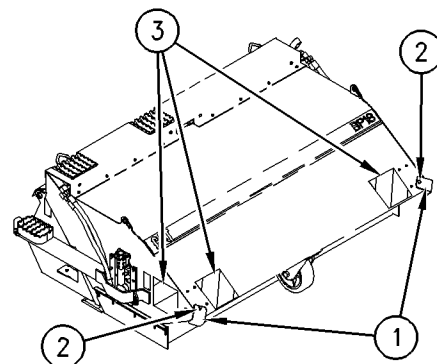

Illustration 135

g00715886

1. Ensure that all roading decals (3) are properly attached to the work tool. There are a total of four decals for the Pickup Broom.

2. Place the guards (1) on the front corners of the broom so that the holes in the guard align with the holes in the broom. Install the bolts and locknuts (2).

**Note:** The guards for the broom can be permanently installed. The broom can be operated with the guards on the broom.

## Vibratory Compactor

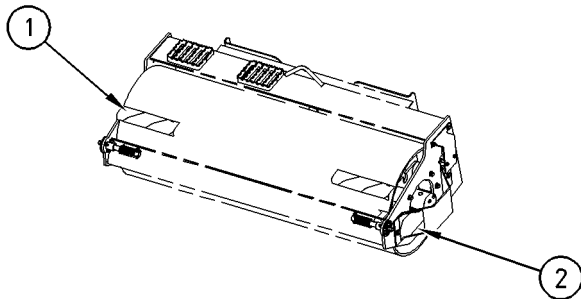

Illustration 136

g00716894

Ensure that the two front decals (1) are attached to the Vibratory Compactor. Make sure that the two side decals (2) are attached to the Vibratory Compactor.

## Snowblower

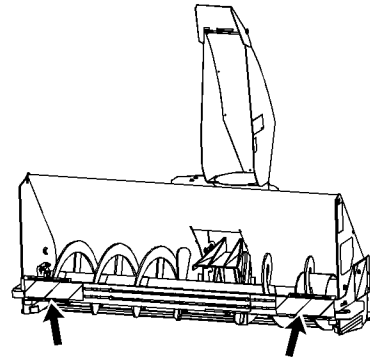

Illustration 137

g02144176

Make sure that the two front roading decals are properly attached to the guard for the snowblower. Make sure that the side roading decals are properly attached to the guard for the snowblower. There are a total of four decals on the guard for the snowblower. Refer to Special Instruction, REHS3983 for more information.

i02127321

## After Roothing the Machine

**SMCS Code:** 7000

When you are finished roading, perform the following procedure in order to prepare the machine for work operation.

1. Enable the work tool control. Enable the auxiliary hydraulic control (if equipped). Enable the high flow control (if equipped). Refer to the Operation and Maintenance Manual, "Hydraulic Lockout and Interlock Override" for the procedure.

### NOTICE

Do not tilt the coupler forward while the coupler position lock pin is installed. Coupler damage may result.

2. Use the following steps to remove the block for the lift arms:
  - a. Enter the machine. Fasten the seat belt. Lower the armrest. Start the engine.
  - b. Disengage the parking brake.
  - c. Raise the lift arms slightly.
  - d. Stop the engine.

Operation Section  
Rooding the Machine



Illustration 138

g00713545

- e. Remove the block for the lift arms.
- f. Start the engine. Disengage the parking brake.
- g. Lower the lift arms all the way.

**Note:** The block for the lift arms can be stored in the storage box in the cab.

3. Turn off the roading lights.
4. Turn off the engine. Remove the locking pin for the coupler.

**Note:** In order to remove the locking pin for the coupler, the coupler may need to be tilted back.

**Note:** The locking pin for the coupler can be stored in the storage box in the cab.

5. Remove all guards and locks for the work tools.
6. Remove the covers from the front work lights and rear work lights. The work lights can be used when you are not roading the machine.

**Note:** The covers for the work lights can be stored in the storage box in the cab.

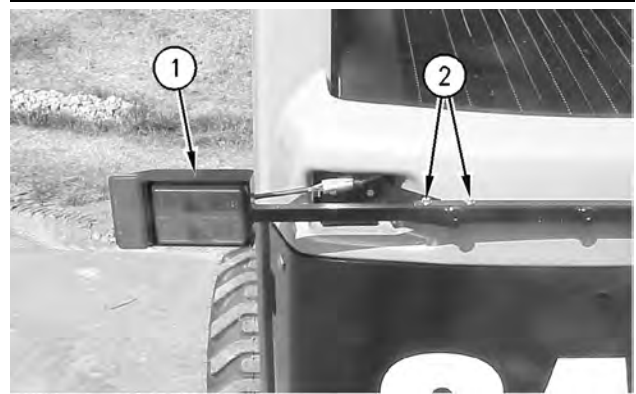

Illustration 139

g00713075

7. Remove two bolts and washers (2) for the tail light (1).

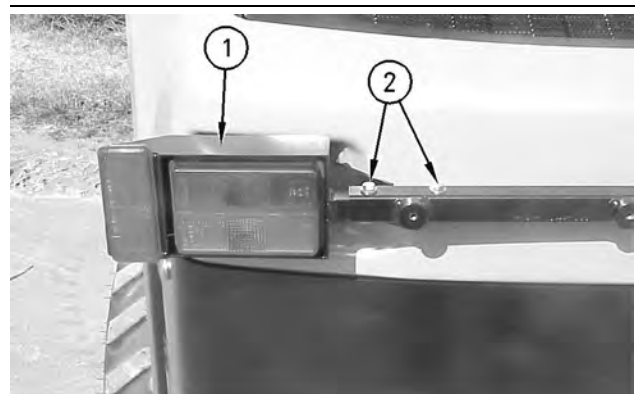

Illustration 140

g00713082

8. Move the rear light (1) to the RETRACTED position. Install the two bolts and washers (2).
9. Repeat step 8 for the other rear light.

i03886175

## Rooding the Machine

**SMCS Code:** 7000

Limitations for TON-kilometers per hour (TON-miles per hour) must be obeyed. Consult your tire dealer for the speed limit of the tires that are used.

Ensure that you have the required licenses and other similar items with you while you road the machine.

Ensure that your machine is equipped to comply with roading regulations.

Learn and obey all traffic regulations when you are roading the machine. Travel at a moderate speed. Observe all speed limitations when you road the machine. Ensure that all work tools remain securely attached to the work tool coupler. Ensure that appropriate locking pins remain in position.

**Note:** In Italy, limit Skid Steer Loaders that are equipped with two speed to low speed while roading.

i04777222

## Lifting and Tying Down the Machine

**SMCS Code:** 7000

### NOTICE

Improper lifting or tiedowns can allow load to shift and can cause injury and damage.

## Lifting the Machine

There are two lifting attachments for the machine:

- The single point lifting eye
- The four-point lifting group

Use one of the lifting attachments in order to lift the machine. Do not attach both lifting devices to the machine at the same time.

For lifting the machine, use properly rated cables and properly rated slings. Position the crane for a level machine lift. Do not drag the machine with a crane.

All work tools must be removed from the machine before the machine is lifted.

**Note:** Do not exceed the weight limit that is shown in Illustration 141 . This film is located on the outside of the right-hand side of the cab.

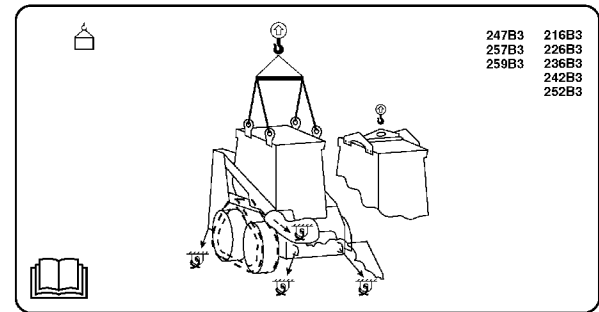

Illustration 141

g02149044

The lifting devices will be mounted on the top of the cab. If any accessory is mounted to the cab roof, the attachment must be removed before lifting the machine.

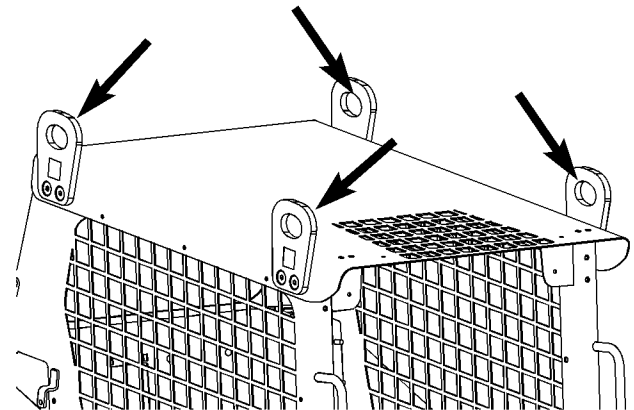

Illustration 142

g02891324

### Points for attaching the lifting devices

When the four-point lifting group is used, the chain for each leg should be a minimum of 1 m (3.3 ft) in length. Keep the machine level during the lift.

Operation Section  
Lifting and Tying Down the Machine

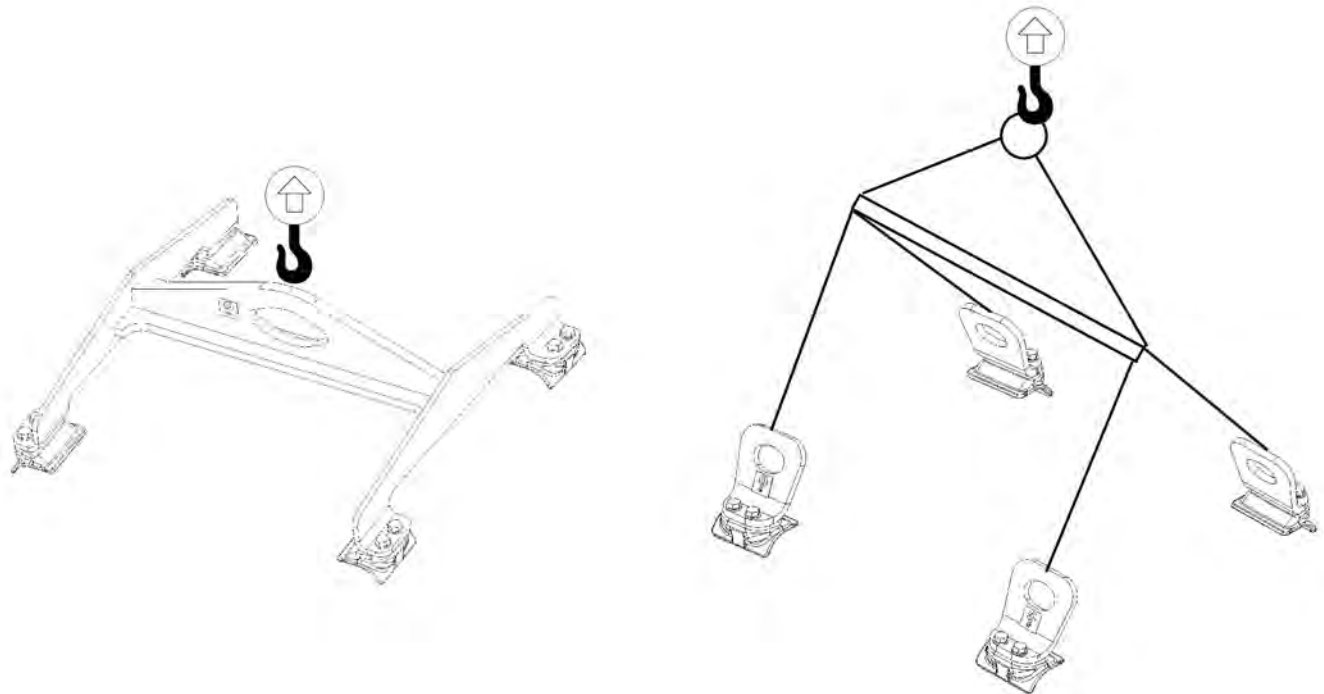

Illustration 143

g02838519

Refer to the Cat Parts Manual for the current part number for the lifting device for your machine. The parts manuals are listed in the Operation and Maintenance Manual, "Reference Information Section".



**Lifting Point – Lifting points are designated by this symbol.**

The weight and the instructions that are given describe the machine as manufactured by Caterpillar. Refer to the Operation and Maintenance Manual, "Specifications" for weight information about your machine.

Do not allow any personnel in the area around the machine.

1. Remove the work tool. If necessary, cover any hydraulic lines and quick disconnect coupler on the machine.
2. Lower the lift arms completely.
3. Turn off the machine.
4. Attach the single point lifting device or the four point lifting device to the machine.

5. Use properly rated cables and slings for lifting. The crane should be in a position that the machine is lifted without swinging.

## Lifting the Grapple Rake

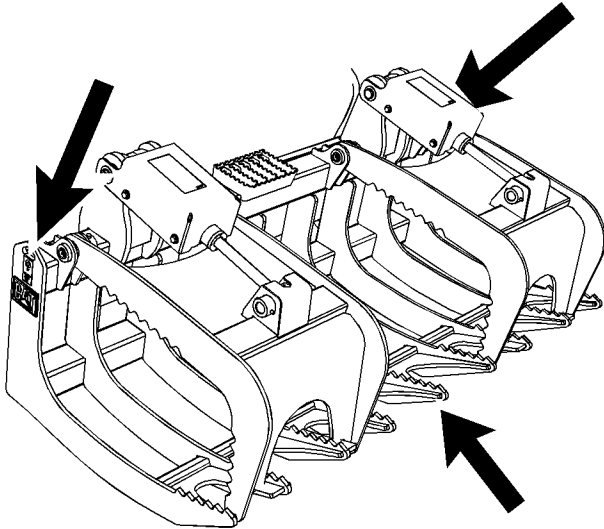

Illustration 144

g01368478

Use properly rated cables and properly rated slings for lifting work tools. Position the crane for a level lift. Do not drag the work tool with a crane.

**Note:** The approximate weight of the 1829 mm (72 inch) Grapple Rake is 458 kg (1010 lb). The approximate weight of the 2134 mm (84 inch) Grapple Rake is 506 kg (1116 lb).

Use two hooks in the lifting eyes on the frame. Use a sling around the front torque tube at the center rake tine.

## Tying Down the Machine

There may be more than one way to tie down the machine. Local regulations should be used to determine the best method. Obey all local and regional governmental regulations.

Operation Section  
Lifting and Tying Down the Machine

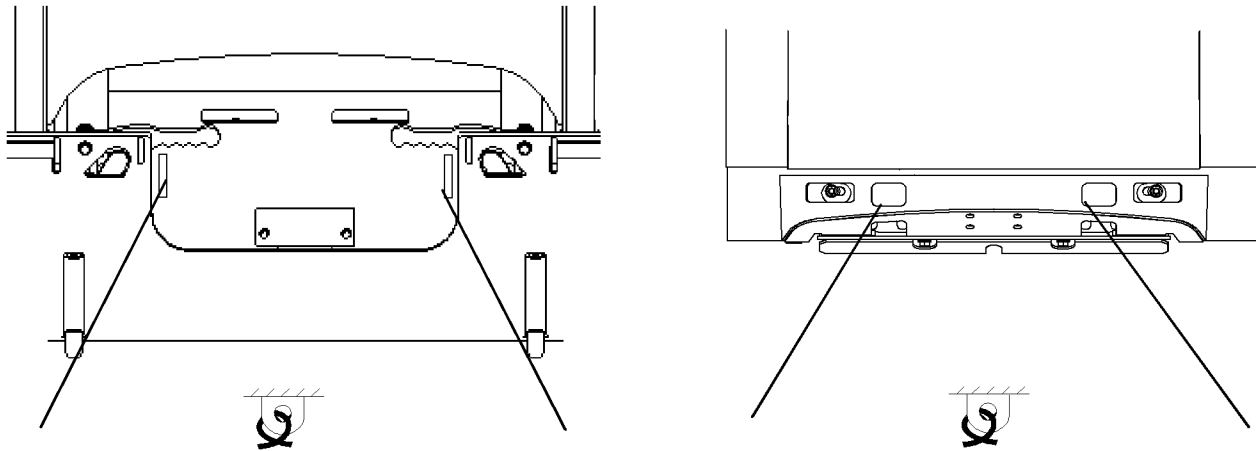

Illustration 145

g02891334

Two eyes are located on the front of the machine frame and two eyes are located on the rear of the machine frame.

Use the tie-downs shown in illustration 145 .

**Note:** Use only the specified locations for tying down the machine. Do not use any other locations in order to tie down the machine. The eyes on the lift arms are for work tool restraint only. Never use the eyes on the lift arms for tie down or lifting.

Install tie-downs at all four locations. Place chocks in front of the machine and behind the machine.



**Tie-Down Point – Tie-down points are designated by this symbol.**

The weight and the instructions that are given describe the machine as manufactured by Caterpillar. Refer to the Operation and Maintenance Manual, “Specifications” for weight information about your machine.

1. Turn off the machine.
2. Use the properly rated cables and shackles for tying down the machine.
3. Use the front eyes and the rear eyes that are provided on the lower frame of your machine. Use corner protection when necessary.

**Note:** Where possible, avoid routing cables over tires or tracks. Avoid contact with the work tool to prevent false tension.

---

**Alternate Method**

---

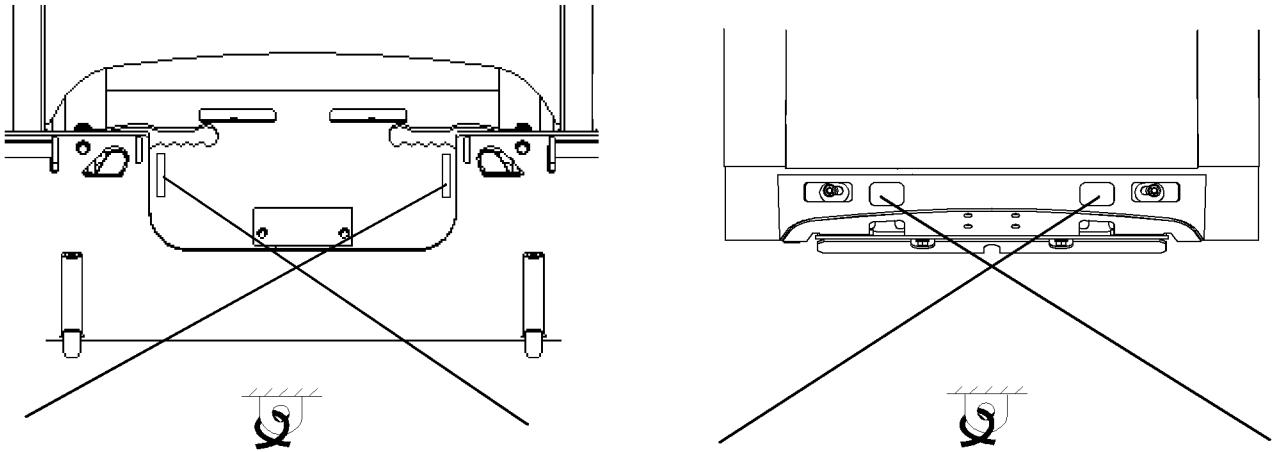

Illustration 146

g02891336

If the alternate method is used, the cable angle should be between 30 degrees and 50 degrees.

**Note:** Use only the specified locations for tying down the machine. Do not use any other locations in order to tie down the machine.

Install tie-downs at all four locations. Place chocks in front of the machine and behind the machine.

Consult your Cat dealer for shipping instructions for your machine.

## Towing Information

i01961474

### Towing the Machine

**SMCS Code:** 7000

If the machine is disabled, the machine should be lifted onto a trailer in order to be transported. Refer to Operation and Maintenance Manual, "Lifting and Tying Down the Machine" for the lifting procedure.

### Retrieval of Machine

If the machine cannot be lifted, use the following guidelines in order to retrieve the machine.

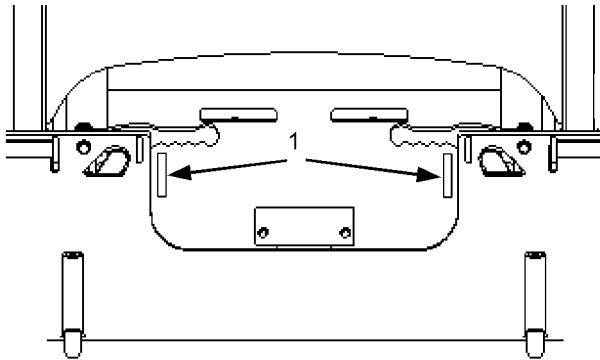

Illustration 147

g01019061

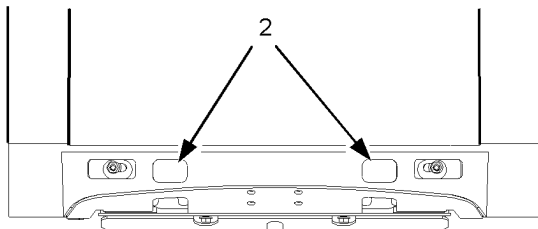

Illustration 148

g01019063

- Attach the line to the towing eyes. Two towing eyes (1) are located on the front of the machine and two towing eyes (2) are located on the rear of the machine. Do not attach the line to any other point on the machine. Do not attach the line to only one towing eye when you are retrieving the machine.
- If a single line is used to pull the machine, then the line must be a minimum of 3 m (10 ft). If two lines are used to pull the machine, then each line must be a minimum of 1.5 m (5.0 ft).
- Do not exceed a maximum pull angle of 20 degrees in any direction.

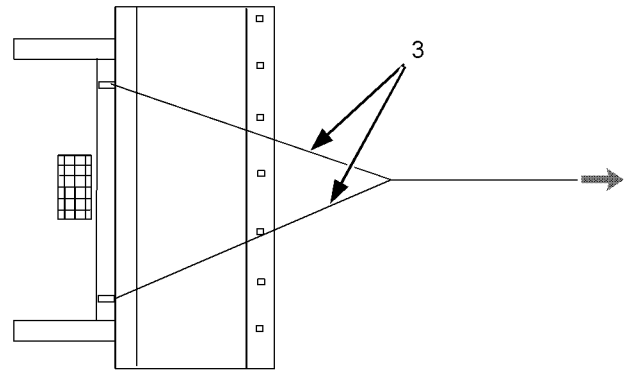

Illustration 149

g01019066

Each of the lines (3) must be a minimum of 1.5 m (5.0 ft).

#### NOTICE

Do not drag the machine for long distances. Damage to the tracks or the tires may occur.

- The strength of the line should be at least 1.5 times the gross weight of the machine.
- Provide shielding in order to protect the operator if the line breaks.

## Engine Starting (Alternate Methods)

i02065056

### Engine Starting with Jump Start Cables

SMCS Code: 1000; 1401; 7000

#### WARNING

Batteries give off flammable fumes that can explode resulting in personal injury.

Prevent sparks near the batteries. They could cause vapors to explode. Do not allow the jump start cable ends to contact each other or the machine.

Do not smoke when checking battery electrolyte levels.

Electrolyte is an acid and can cause personal injury if it contacts skin or eyes.

Always wear eye protection when starting a machine with jump start cables.

Improper jump start procedures can cause an explosion resulting in personal injury.

Always connect the positive (+) to positive (+) and the negative (-) to negative (-).

Jump start only with an energy source with the same voltage as the stalled machine.

Turn off all lights and accessories on the stalled machine. Otherwise, they will operate when the energy source is connected.

#### NOTICE

To prevent damage to engine bearings and to electrical circuits when you jump start a machine, do not allow the stalled machine to touch the machine that is used as the electrical source.

Severely discharged maintenance free batteries do not fully recharge from the alternator after jump starting. The batteries must be charged to proper voltage with a battery charger. Many batteries thought to be unusable are still rechargeable.

Use only equal voltage for starting. Check the battery and starter voltage rating of your machine. Use only the same voltage for jump starting. Use of a welder or higher voltage damages the electrical system. This machine has a 12 volt starting system. Use only the same voltage for jump starting.

Refer to Special Instruction, SEHS7633, "Battery Test Procedure" available from your Caterpillar dealer, for complete testing and charging information.

1. Engage the parking brake. Lower the work tools to the ground.

**Reference:** Refer to Operation and Maintenance Manual, "Equipment Lowering with Engine Stopped".

2. Move all control levers to the HOLD or NEUTRAL position.

3. Turn the engine start switch key to the OFF position and turn all accessory switches to the OFF position.

4. Move the machine that is being used as an electrical source near the stalled machine so that the jump start cables reach the stalled machine.  
**Do not allow the machines to contact each other.**

5. Stop the engine of the machine that is being used as an electrical source. If you are using an auxiliary power source, turn off the charging system.

6. Ensure that battery caps on both machines are tight and correctly placed. Ensure that batteries in the stalled machine are not frozen.

7. Connect the positive jump start cable to the positive cable terminal of the discharged battery.

Do not allow the positive cable clamps to contact any metal except for the battery terminals.

8. Connect the other positive end of the jump start cable to the positive cable terminal of the electrical source.

Operation Section  
Engine Starting with Jump Start Cables

---

9. Connect one negative end of the jump start cable to the negative cable terminal of the electrical source.
10. Connect the other negative end of the jump start cable to the engine block or to the frame of the stalled machine. **Do not connect the jump start cable to the battery post. Do not allow the jump start cables to contact the battery cables, the fuel lines, the hydraulic lines, or any moving parts.**
11. Start the engine of the machine that is being used as an electrical source or energize the charging system on the auxiliary power source.
12. Wait at least two minutes before you attempt to start the stalled machine. This will allow the battery in the stalled machine to partially charge.
13. Attempt to start the stalled engine.

**Reference:** For the correct starting procedure, refer to Operation and Maintenance Manual, "Engine Starting".

14. After the stalled engine starts, disconnect the negative jump start cable from the stalled machine.
15. Disconnect the negative jump start cable from the negative terminal of the electrical source.
16. Disconnect the positive jump start cable from the positive terminal of the electrical source.
17. Disconnect the positive jump start cable from the positive terminal of the stalled machine.
18. Conclude the failure analysis on the starting system of the stalled machine and/or on the charging system of the stalled machine. Check the machine while the engine is running and the charging system is in operation.

## Maintenance Section

## Maintenance Access

i01961574

### Access Doors and Covers

SMCS Code: 7273-573; 7273-572

#### Engine Access Door

**Note:** A pinch point exists between the top of the engine access door and the radiator guard. Keep hands away from this area when you close the engine access door.

The engine access door is located on the back of the machine.

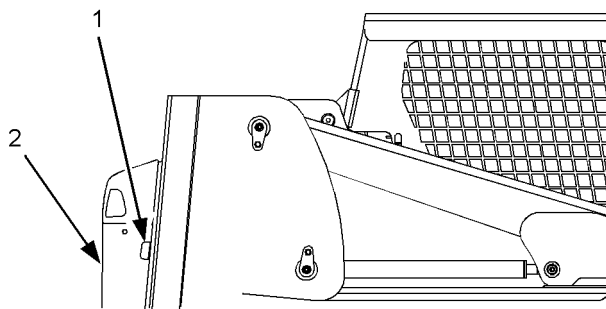

Illustration 150

g01019131

1. Pull the release lever (1) in order to open the engine access door (2).

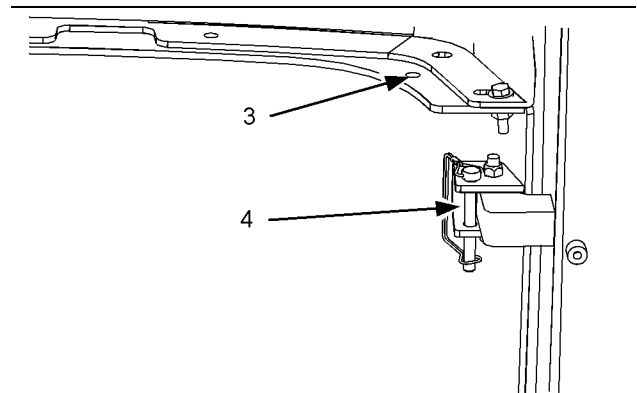

Illustration 151

g01019162

2. Move the retaining pin from the stored position (3) and put the retaining pin in the LOCKED position (4). This will prevent the engine access door from closing inadvertently.
3. In order to close the engine access door, put the retaining pin in the STORED position.
4. Close the engine access door.

i03879812

### Cab Tilting

SMCS Code: 7301-509; 7301-506

#### **⚠ WARNING**

Do not go beneath cab unless cab is empty and support lever is engaged.

Failure to follow the instructions or heed the warnings could result in injury or death.

#### **⚠ WARNING**

Do not tilt the cab using an open door. The door must be closed and latched when lifting the cab. The door may become dislodged from its hinges and may cause serious personal injury or death.

### Tilting the Cab Upward

1. Park the machine on level ground.

**Note:** Empty the water tank (if equipped) before you tilt the cab.

## Maintenance Section

### Cab Tilting

2. Lower the loader arms fully. If you tilt the cab upward with the loader lift arms in the RAISED position, you must engage the brace for the loader lift arms. See Operation and Maintenance Manual, "Loader Lift Arm Brace Operation" for the process for engaging the brace for the loader lift arms.
3. Turn the engine start switch key to the OFF position.
4. Place supports under the rear of the machine in order to support the machine while the cab is tilted.

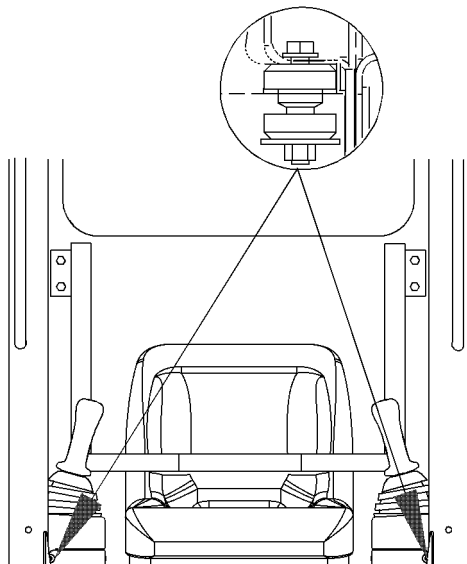

Illustration 152

g01025254

5. Remove the two front bolts for the ROPS.
6. Close the cab door and ensure that the door is latched.
7. Tilt the cab upward. Stand on the ground when you tilt the cab.

**Note:** More than one person may be needed to tilt the cab.

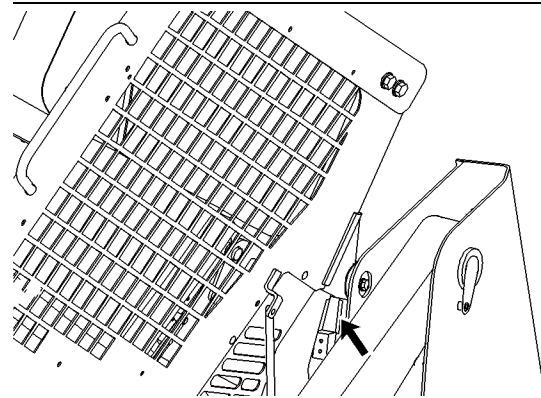

Illustration 153

g00954946

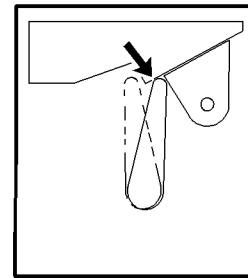

Illustration 154

g00952728

The cab support lever is in the ENGAGED position.

8. Make sure that the cab support lever is in the ENGAGED position.

## Tilting the Cab Downward

**Note:** More than one person may be needed to tilt the cab.

1. Ensure that all persons are not under the cab. Remove all of the tools and unsecured items that are underneath the cab.

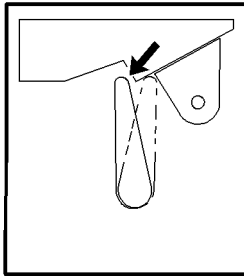

Illustration 155

g00952719

The cab support lever is shown in the DISENGAGED position.

2. Tilt the cab upward. Move the cab support lever to the DISENGAGED position.
3. Tilt the cab downward and install the bolts for the ROPS. Torque the bolts to  $125 \pm 20 \text{ N}\cdot\text{m}$  ( $92 \pm 15 \text{ lb}\cdot\text{ft}$ ).
4. Remove the supports from the rear of the machine.

i01961564

## Loader Lift Arm Brace Operation

**SMCS Code:** 6119-011-AB; 6119-012-AB

**S/N:** AS21-Up  
**S/N:** CD31-Up  
**S/N:** KB31-Up  
**S/N:** SNA1-Up  
**S/N:** MWD1-Up  
**S/N:** A9H1-Up  
**S/N:** TNK1-Up  
**S/N:** ESL1-Up  
**S/N:** TSL1-Up  
**S/N:** JXM1-Up  
**S/N:** DSN1-Up

### **WARNING**

Loader lift arm brace must be in place when working under raised lift arms.

Failure to follow the instructions or heed the warnings could result in injury or death.

## Engage the Lift Arm Brace (Radial Lift)

1. Empty the work tool. Remove the work tool. Park the machine on level ground. Lower lift arms to the ground. Stop the engine and exit the machine.

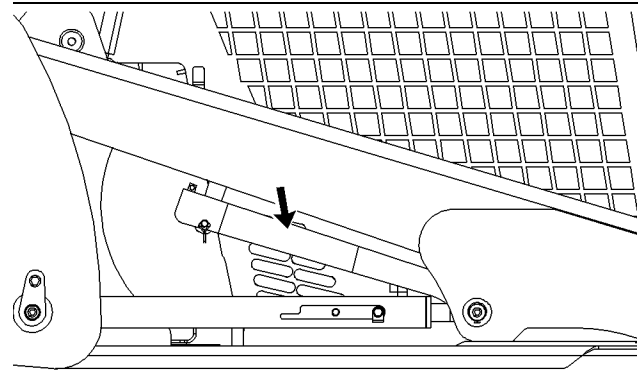

Illustration 156

g00930196

2. Remove the pin that holds the lift arm brace in the stored position.
3. Lower the lift arm brace to rest on the cylinder housing.
4. Mount the machine. Secure the seat belt and lower the armrest. Start the engine.
5. Raise the lift arms until the brace falls onto the cylinder rod. Slowly lower the lift arms until the brace stops movement.

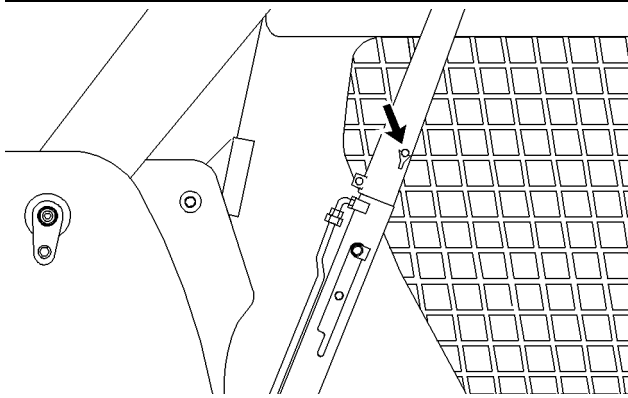

Illustration 157

g00952492

6. Stop the engine. Exit the machine. Secure the retaining pin through the brace below the cylinder rod.

### Disengage the Lift Arm Brace (Radial Lift)

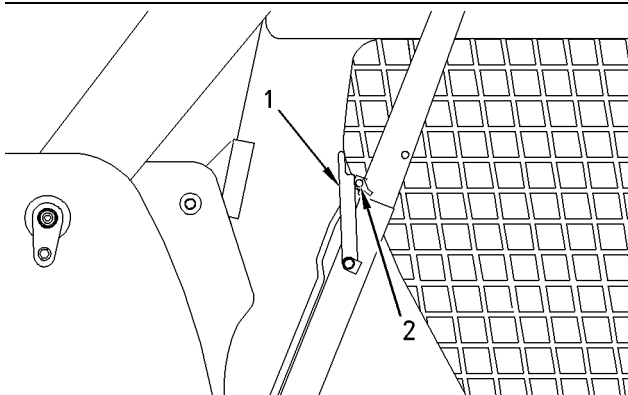

Illustration 158

g00952586

1. Remove the retaining pin from the brace and install the pin (2) in the holding block.
2. Detach and swing the pivot lever (1) clockwise onto the retaining pin.
3. Mount the machine. Secure the seat belt and lower the armrest. Start the engine.

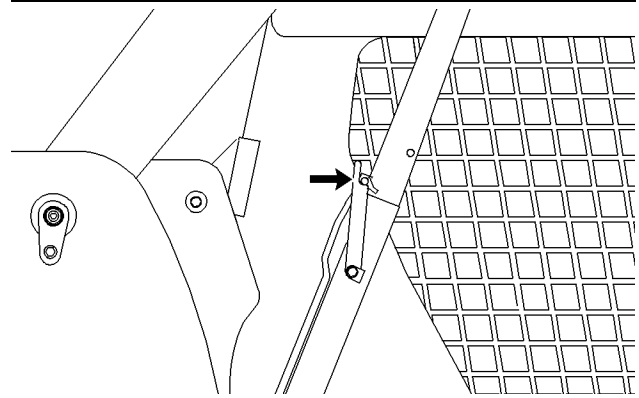

Illustration 159

g00952609

4. Slowly raise the loader lift arms until the lever engages the retaining pin.
5. Slowly lower the lift arms to the ground. Stop the engine. Exit the machine.
6. Raise and secure the brace to the lift arm with the retaining pin.
7. Install the pivot lever into the STORED position.

### Engage the Lift Arm Brace (Extended Lift)

1. Empty the work tool. Remove the work tool. Park the machine on level ground. Raise the lift arms to maximum height.
2. Remain in the seat with the seat belt fastened until the brace is installed.

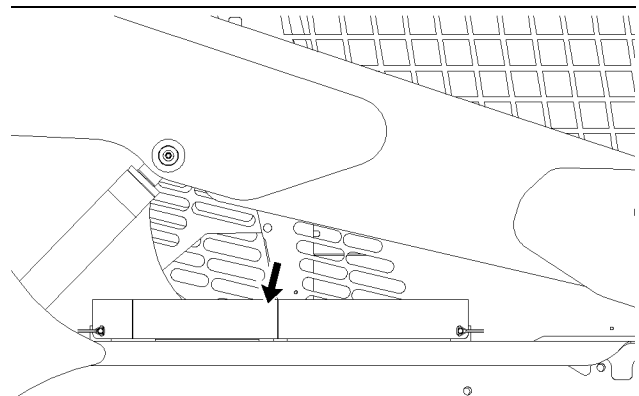

Illustration 160

g00930202

3. A second person must remove the brace from the storage position by removing the retaining pins.

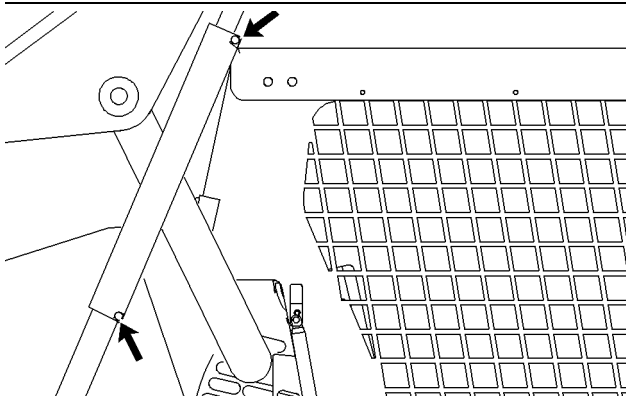

Illustration 161

g00952659

4. The second person should then install the brace over the rod of one of the lift cylinders.
5. Lower the loader arms slowly until the brace is held tightly between the rod and the cylinder.
6. Secure the two retaining pins through the brace below the rod.

### Disengage the Lift Arm Brace (Extended Lift)

1. Mount the machine. Fasten the seat belt. Lower the armrest and remain in the seat until the brace is removed.
2. Slowly raise the lift arms until the brace is free.
3. A second person must remove the retaining pins and the brace from the rod.
4. Slowly lower the lift arms to the ground.
5. The second person should return the brace to the storage location. Attach the brace with the retaining pins.

i03917798

## Loader Lift Arm Brace Operation

**SMCS Code:** 6119-011-AB; 6119-012-AB

**S/N:** HR21-Up  
**S/N:** B7H1-Up  
**S/N:** PWK1-Up  
**S/N:** SRS1-Up  
**S/N:** DXZ1-Up  
**S/N:** YYZ1-Up

### **WARNING**

**Loader lift arm brace must be in place when working under raised lift arms.**

**Failure to follow the instructions or heed the warnings could result in injury or death.**

### Engage the Lift Arm Brace

1. Empty the work tool. Remove the work tool. Park the machine on level ground. Raise the lift arms to maximum height, then lower the lift arms 76.2 mm (3.0 inch).
2. Remain in the seat with the seat belt fastened until the brace is installed.

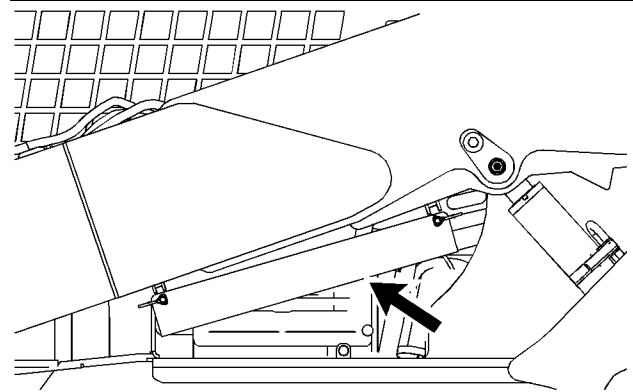

Illustration 162

g02151078

3. A second person must remove the brace from the storage position by removing the retaining pins.

## Maintenance Section Radiator Tilting

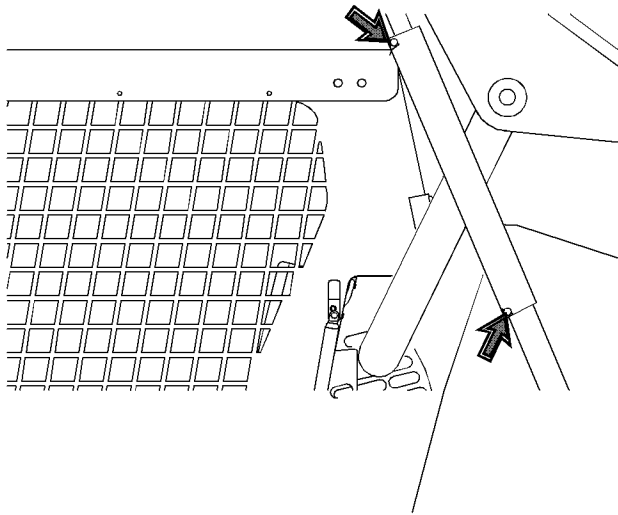

Illustration 163

g02151079

4. The second person should then install the brace over the rod of one of the lift cylinders.
5. Lower the loader arms slowly until the brace is held tightly between the rod and the cylinder.
6. Secure the two retaining pins through the brace below the rod.

### Disengage the Lift Arm Brace

1. Mount the machine. Fasten the seat belt. Lower the armrest and remain in the seat until the brace is removed.
2. Slowly raise the lift arms until the brace is free.
3. A second person must remove the retaining pins and the brace from the rod.
4. Slowly lower the lift arms to the ground.
5. The second person should return the brace to the storage location. Attach the brace with the retaining pins.

i01961858

## Radiator Tilting

**SMCS Code:** 1353-509; 1353-506

1. Open the engine access door. Refer to Operation and Maintenance Manual, "Access Doors and Covers".

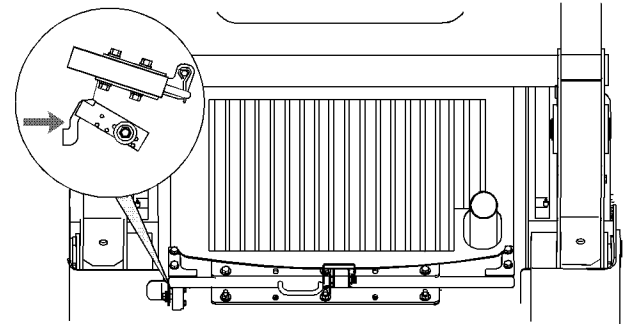

Illustration 164

g01019329

2. The release lever for the radiator latch is located on the left side or the right side of the radiator. Pull the release lever for the radiator latch. Tilt the radiator upward.

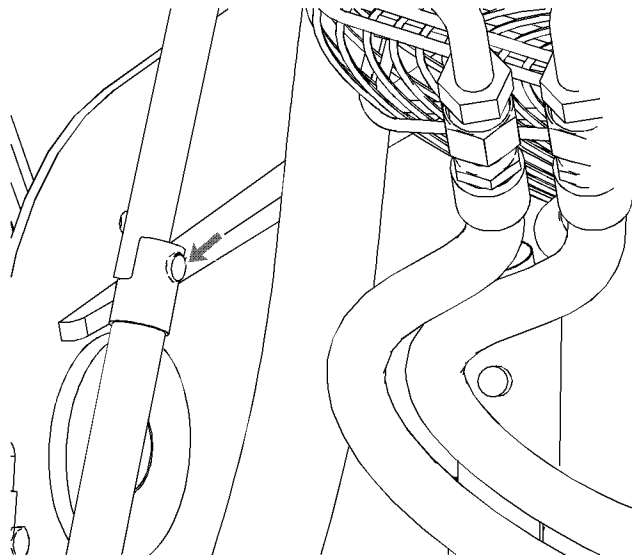

Illustration 165

g01028581

3. The strut lock is located on the right side or the left side of the engine compartment. Make sure that the strut lock is in the LOCKED position.
4. In order to tilt the radiator downward, push the strut lock to the left.
5. Tilt the radiator downward. Make sure that the radiator is in the LOCKED position.
6. Close the engine access door.

## Tilting the Radiator Guard

1. Open the engine access door. Refer to Operation and Maintenance Manual, "Access Doors and Covers".

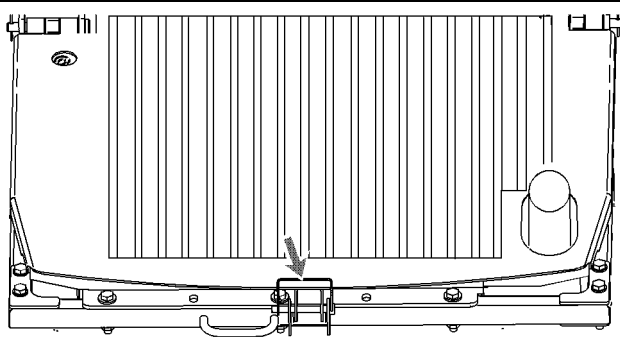

Illustration 166

g01019340

2. Remove the retaining pin from the radiator guard.  
Tilt the radiator guard upward.
3. In order to tilt the radiator guard downward, pull down on the radiator guard and install the retaining pin.

# Lubricant Viscosities and Refill Capacities

i04777228

## Lubricant Viscosities

SMCS Code: 7581

### Selecting the Viscosity

Ambient temperature is the temperature of the air in the immediate vicinity of the machine. The temperature may differ due to the machine application from the generic ambient temperature for a geographic region. When selecting the proper oil viscosity for use, review **both** the regional ambient temperature and the potential ambient temperature for a given machine application. Generally, use the higher temperature as the criterion for the selection of the oil viscosity. Generally, use the highest oil viscosity that is allowed for the ambient temperature when you start the machine. Refer to the “Lubricant Viscosities for Ambient Temperatures” tables for guidance. In cold-weather applications, the preferred method is to use properly sized machine compartment heaters and a higher viscosity grade oil. Thermostatically controlled heaters that circulate the oil are preferred.

The proper oil viscosity grade is determined by the minimum ambient temperature (the air in the immediate vicinity of the machine). The ambient temperature is the temperature when the machine is started and while the machine is operated. In order to determine the proper oil viscosity grade, refer to the “Min” column in the table. This information reflects the coldest ambient temperature condition for starting a cold machine and for operating a cold machine. Refer to the “Max” column in the table in order to select the oil viscosity grade for operating the machine at the highest temperature that is anticipated. Unless specified otherwise in the “Lubricant Viscosities for Ambient Temperatures” tables, use the highest oil viscosity that is allowed for the ambient temperature when you start the machine.

Machines that are operated continuously should use oils that have the higher oil viscosity in the final drives and in the differentials. The oils that have the higher oil viscosity will maintain the highest possible oil film thickness. Refer to this Special Publication, General Information for Lubricants article, Lubricant Viscosities tables, and any associated footnotes. Consult your Cat dealer if additional information is needed.

**Note:** SAE 0W and SAE 5W oils, where allowed for use in non-hydraulic system compartments, are not recommended for use in machines that are operated continuously and/or are heavily loaded. Refer to the “Lubricant Viscosities for Ambient Temperatures” tables for guidance. The oils that have the higher oil viscosity will maintain the highest possible oil film thickness. Consult your Cat dealer if additional information is needed.

**Note:** Oil viscosity grade selection is also machine compartment specific. Some machine models and/or machine compartments do not allow the use of all available viscosity grades. For guidance on selecting oil viscosity, refer to the “Lubricant Viscosities for Ambient Temperatures” tables.

**Note:** Generally, use the highest oil viscosity that is available to meet the requirement for the temperature at start-up.

---

#### NOTICE

Proper oil viscosity **AND** oil type/specification are required to maximize machine compartment performance and life. Do **NOT** use only oil viscosity, or only oil type to determine the machine compartment oil selection. Using only the oil viscosity or only the oil type to determine a machine compartment oil selection can lead to reduced performance and compartment failure. Refer to the “Lubricant Viscosities for Ambient Temperatures” tables and to ALL of the associated footnotes.

---

#### NOTICE

Not following the recommendations found in the “Lubricant Viscosities for Ambient Temperatures” tables and associated footnotes can lead to reduced performance and compartment failure.

---

#### NOTICE

In colder ambient conditions a machine warm-up procedure and/or supplemental machine fluid compartment heat may be required. Machine specific warm-up procedures can typically be found in the Operation and Maintenance Manual for the machine. In addition, generic machine warm-up procedures can be found in this Special Publication, “Procedures for Machines that are Used in Cold Weather - (Generic)” topic. Some of the “Lubricant Viscosities for Ambient Temperatures” tables in this Special Publication include footnotes that address compartment warm-up.

## General Information for Lubricants

The information provided in this “Lubricant Viscosities for Ambient Temperatures” article and Tables should be used with the information provided in the “Lubricant Specifications” section (Maintenance Section) of this Special Publication.

---

**NOTICE**

Cat does not warrant the quality or performance of non-Cat fluids and greases.

---



---

**NOTICE**

Not following the recommendations found in this Special Publication can lead to reduced performance and compartment failure.

---



---

**NOTICE**

Do NOT use only the oil viscosities when determining the recommended oil for an engine compartment. The oil type (performance requirements) MUST also be used.

---

**Note:** Some machine models and/or machine compartments do NOT allow the use of all available oil viscosity grades.

**Note:** Only use the oil type and the specification that is recommended for the various machine compartments.

**Note:** Some machine compartments allow the use of more than one oil type. For the best results, do not mix oil types.

**Note:** Different brand oils may use different additive packages to meet the various machine compartment performance specification recommendations. For the best results, do not mix oil brands.

**Note:** The availability of the various Cat oils will vary by region.

**Note:** SAE 10W viscosity grade oil used in most Cat machine compartments must have a minimum viscosity of 5.8 cSt at 100 °C (212 °F) ("ASTM D445").

**Note:** The minimum acceptable viscosity for commercial alternative oils in most Cat machine hydraulic and hydrostatic transmission systems is 6.6 cSt at 100 °C (212 °F) ("ASTM D445").

Cat GO (Gear Oil) is available in SAE 80W-90 and SAE 85W-140 viscosity grades.

Cat SYNTHETIC GO is an SAE 75W-140 viscosity grade oil.

Cat FDAO (Final Drive and Axle Oil) exceeds the FD-1 oil performance requirements.

Cat TDTO-TMS (Transmission Multi-Season Oil) is a synthetic blend that exceeds the TO-4M multigrade oil performance requirements.

**Note:** Cat oils are the **preferred** oils. ALL other oil types and specifications that are listed in the applicable section are acceptable oils.

When you are operating the machine in temperatures below -20°C (-4°F), refer to Special Publication, SEBU5898, "Cold Weather Recommendations". This publication is available from your Cat dealer.

For cold-weather applications where transmission oil SAE 0W-20 is recommended, Cat Cold Weather TDTO is the first choice oil. Second choice oils for cold-weather transmission applications are commercial oils of full synthetic basestock that do not have viscosity index improvers and do meet the performance requirements of the Cat TO-4 specification. Typical lubricant viscosity grades are SAE 0W-20, SAE 0W-30, and SAE 5W-30. Commercial oils that contain a Cat TO-4 additive package and a lubricant viscosity grade of SAE 0W-20, SAE 0W-30, or SAE 5W-30 are a last choice.

The footnotes are a key part of the tables. Read ALL footnotes that pertain to the machine compartment in question.

## Lubricant Viscosities for Ambient Temperatures

### General Lubricants

Cat FDAO SYN Cat FDAO or commercial FD - 1 are the preferred oil types to maximize gear and bearing life. Do not use Cat FDAO, Cat FDAO SYN, or Cat FD-1 in compartments containing clutches and/or brakes. Cat TDTO, Cat TDTO-TMS, or commercial TO-4 oil types must be used in any compartment containing friction material unless specified otherwise by Cat.

For the Final Drives in severe usage or in continuous operations, WARM-UP is required. Exercise the final drives for several minutes with the engine at a partial throttle in order to warm up the oil prior to production operation.

### Engine Crankcase

Refer to the "General Information for Lubricants" article for important lubricant information.

Supplemental heat is recommended for cold-soaked starts below the minimum ambient temperature. The parasitic load and other factors will determine if supplemental heat is required for cold-soaked starts that are above the minimum temperature that is stated. Cold-soaked starts occur when the engine has not been operated for time. The oil becomes more viscous due to cooler ambient temperatures.

For oil recommendations for Tier 4 EPA certified engines, EU stage IIIB and IV type approved engines, and Japan Step IV approved engines refer to the "Engine Oil" section in this Special Publication.

Refer to the "Lubricant Information" section in this Special Publication for a list of all Cat engine oils.

Cat DEO-ULS SYN and Cat DEO SYN are SAE 5W-40 viscosity grade oils.

Maintenance Section  
Lubricant Viscosities

Cat Cold Weather DEO-ULS is an SAE 0W-30 viscosity grade oil.

Cat ECF refers to Engine Crankcase Fluid specifications. Refer to the "Maintenance" section in this Special Publication, "Lubricant Information" for details. Commercial alternative diesel engine oils must meet one or more of these Cat ECF specifications.

Table 27

| Engine Crankcase      |                                       |                 |      |     |     |     |
|-----------------------|---------------------------------------|-----------------|------|-----|-----|-----|
| Compartment or System | Oil Type and Performance Requirements | Oil Viscosities | °C   |     | °F  |     |
|                       |                                       |                 | Min  | Max | Min | Max |
| Engine Crankcase      | Cat DEO-ULS Cold Weather              | SAE 0W-40       | -40  | 40  | -40 | 104 |
|                       | Cat DEO-ULS<br>Cat DEO                | SAE 10W-30      | -18  | 40  | 0   | 104 |
|                       | Cat DEO-ULS<br>Cat DEO                | SAE 15W-40      | -9.5 | 50  | 15  | 122 |

## Hydraulic System

- Cat DEO-ULS Cold Weather

Refer to the "Lubricant Information" section in the latest revision of the Special Publication, SEBU6250, "Caterpillar Machine Fluids Recommendations" for detailed information. This manual may be found on the Web at [Safety.Cat.com](http://Safety.Cat.com).

The following are the preferred oils for use in most Cat machine hydraulic systems:

- Cat HYDO Advanced 10 SAE 10W
- Cat HYDO Advanced 30 SAE 30W
- Cat BIO HYDO Advanced

**Cat HYDO Advanced fluids have a 50% increase in the standard oil drain interval** for machine hydraulic systems (3000 hours versus 2000 hours) over second and third choice oils when you follow the maintenance interval schedule for oil filter changes and for oil sampling that is stated in the Operation and Maintenance Manual for your particular machine. 6000 hour oil drain intervals are possible when using S·O·S Services oil analysis. Consult your Cat dealer for details. When switching to Cat HYDO Advanced fluids, cross contamination with the previous oil should be kept to less than 10%.

**Second choice** oils are listed below.

- Cat MTO
- Cat DEO
- Cat DEO-ULS
- Cat TDTO
- Cat TDTO Cold Weather
- Cat TDTO-TMS

Table 28

| Hydraulic System      |   |                      |     |     |     |     |
|-----------------------|---|----------------------|-----|-----|-----|-----|
| Compartment or System | Oil Type and Performance Requirements           | Oil Viscosities      | °C  |     | °F  |     |
|                       |   |                      | Min | Max | Min | Max |
| Hydraulic System      | Cat HYDO Advanced 10 <sup>(1)</sup><br>Cat TDTO | SAE 10W              | -20 | 40  | -4  | 104 |
|                       | Cat HYDO Advanced 30<br>Cat TDTO                | SAE 30               | 0   | 50  | 32  | 122 |
|                       | Cat BIO HYDO Advanced                           | "ISO 46" Multi-Grade | -30 | 45  | -22 | 113 |
|                       | Cat MTO<br>Cat DEO-ULS<br>Cat DEO               | SAE10W-30            | -20 | 40  | -4  | 104 |
|                       | Cat DEO-ULS<br>Cat DEO                          | SAE15W-40            | -15 | 50  | 5   | 122 |
|                       | Cat TDTO-TMS                                    | Multi-Grade          | -15 | 50  | 5   | 122 |
|                       | Cat DEO-ULS Cold Weather                        | SAE0W-40             | -40 | 40  | -40 | 104 |
|                       | Cat TDTO Cold Weather                           | SAE 0W-20            | -40 | 40  | -40 | 104 |

(1) -20° C (-4° F) to 50° C (122° F) if equipped with the High Ambient Cooling Attachment

## Drive Train Components

Refer to the "Lubricant Information" section in the latest revision of the Special Publication, SEBU6250, "Caterpillar Machine Fluids Recommendations" for detailed information. This manual may be found on the Web at [Safety.Cat.com](http://Safety.Cat.com).

When you are operating the machine in temperatures below -20°C (-4°F), refer to Special Publication, SEBU5898, "Cold Weather Recommendations". This publication is available from your Cat dealer.

Table 29

| Drive Chain Case      |                                       |                 |      |     |     |     |
|-----------------------|---------------------------------------|-----------------|------|-----|-----|-----|
| Compartment or System | Oil Type and Performance Requirements | Oil Viscosities | °C   |     | °F  |     |
|                       |                                       |                 | Min  | Max | Min | Max |
| Drive Chain Case      | Cat DEO-ULS Cold Weather              | SAE 0W-40       | -40  | 40  | -40 | 104 |
|                       | Cat DEO-ULS<br>Cat DEO                | SAE 10W-30      | -18  | 40  | 0   | 104 |
|                       | Cat DEO-ULS<br>Cat DEO                | SAE 15W-40      | -9.5 | 50  | 15  | 122 |

Table 30

| Multi-terrain and Compact track Loaders                        |                                       |                 |     |     |     |     |
|--|---------------------------------------|-----------------|-----|-----|-----|-----|
| Compartment or System  | Oil Type and Performance Requirements | Oil Viscosities | °C  |     | °F  |     |
|  |                                       |                 | Min | Max | Min | Max |
| Final Drive for Multiterrain Loaders and Compact Track Loaders | Cat Synthetic GO                      | SAE 75W-140     | -30 | 45  | -22 | 113 |

## Special Lubricants

### Grease

In order to use a non-Cat grease, the supplier must certify that the lubricant is compatible with Cat grease.

Each pin joint should be flushed with the new grease. Ensure that all old grease is removed. Failure to meet this requirement may lead to failure of a pin joint.

Table 31

| Recommended Grease          |                         |              |     |     |     |     |
|-----------------------------|-------------------------|--------------|-----|-----|-----|-----|
| Compartment or System       | Grease Type             | NLGI Grade   | °C  |     | °F  |     |
|                             |                         |              | Min | Max | Min | Max |
| External Lubrication Points | Cat Advanced 3Moly      | NLGI Grade 2 | -20 | 40  | -4  | 104 |
|                             | Cat Ultra 5Moly         | NLGI Grade 2 | -30 | 50  | -22 | 122 |
|                             |                         | NLGI Grade 1 | -35 | 40  | -31 | 104 |
|                             |                         | NLGI Grade 0 | -40 | 35  | -40 | 95  |
|                             | Cat Arctic Platinum     | NLGI Grade 0 | -50 | 20  | -58 | 68  |
|                             | Cat Desert Gold         | NLGI Grade 2 | -20 | 60  | -4  | 140 |
| General Bearing Lubrication | Cat Multipurpose Grease | NLGI Grade 2 | -30 | 40  | -22 | 104 |

### Diesel Fuel Recommendations

Diesel fuel must meet “Cat Specification for Distillate Fuel” and the latest versions of “ASTM D975” or “EN 590” in order to ensure optimum engine performance. Refer to Special Publication, SEBU6250, “Caterpillar Machine Fluids Recommendations” for the latest fuel information and for Cat fuel specification. This manual may be found on the Web at [Safety.Cat.com](http://Safety.Cat.com).

The preferred fuels are distillate fuels. These fuels are commonly called diesel fuel, furnace oil, gas oil, or kerosene. These fuels must meet the “Caterpillar Specification for Distillate Diesel Fuel for Off-Highway Diesel Engines”. Diesel Fuels that meet the Cat specification will help provide maximum engine service life and performance.

#### Misfueling with fuels of high sulfur level can have the following negative effects:

- Reduce engine efficiency and durability
- Increase the wear
- Increase the corrosion
- Increase the deposits
- Lower fuel economy
- Shorten the time period between oil drain intervals (more frequent oil drain intervals)
- Increase overall operating costs

- Negatively impact engine emissions

Failures that result from the use of improper fuels are not Caterpillar factory defects. Therefore the cost of repairs would not be covered by a Caterpillar warranty.

Caterpillar does not require the use of ULSD in off road and machine applications that are not Tier 4/ Stage IIIB certified engines. ULSD is not required in engines that are not equipped with after treatment devices.

Follow operating instructions and fuel tank inlet labels, if available, in order to ensure that the correct fuels are used.

Refer to Special Publication, SEBU6250, "Caterpillar Machine Fluids Recommendations" for more details about fuels and lubricants. This manual may be found on the Web at Safety.Cat.com.

## Fuel Additives

Cat Diesel Fuel Conditioner and Cat Fuel System Cleaner are available for use when needed. These products are applicable to diesel and biodiesel fuels. Consult your Cat dealer for availability.

## Biodiesel

Biodiesel is a fuel that can be made from various renewable resources that include vegetable oils, animal fat, and waste cooking oil. Soybean oil and rapeseed oil are the primary vegetable oil sources. In order to use any of these oils or fats as fuel, the oils or fats are chemically processed (esterified). The water and contaminants are removed.

U.S. distillate diesel fuel specification "ASTM D975-09a" includes up to B5 (5 percent) biodiesel. Currently, any diesel fuel in the U.S. may contain up to B5 biodiesel fuel.

European distillate diesel fuel specification "EN 590" includes up to B5 (5 percent) and in some regions up to B7 (7 percent) biodiesel. Any diesel fuel in Europe may contain up to B5 or in some regions up to B7 biodiesel fuel.

When biodiesel fuel is used, certain guidelines must be followed. Biodiesel fuel can influence the engine oil, aftertreatment devices, non-metallic, fuel system components, and others. Biodiesel fuel has limited storage life and has limited oxidation stability. Follow the guidelines and requirements for engines that are seasonally operated and for standby power generation engines.

In order to reduce the risks associated with the use of biodiesel, the final biodiesel blend and the biodiesel fuel used must meet specific blending requirements.

All the guidelines and requirements are provided in the latest revision of Special Publication, SEBU6250, "Caterpillar Machine Fluids Recommendations". This manual may be found on the Web at Safety.Cat.com.

## Coolant Information

The information provided in this "Coolant Recommendation" section should be used with the "Lubricants Information" provided in the latest revision of Special Publication, SEBU6250, "Caterpillar Machine Fluids Recommendations". This manual may be found on the Web at Safety.Cat.com.

The following two types of coolants may be used in Cat diesel engines:

**Preferred** – Cat ELC (Extended Life Coolant)

**Acceptable** – Cat DEAC (Diesel Engine Antifreeze/Coolant)

### NOTICE

Never use water alone as a coolant. Water alone is corrosive at engine operating temperatures. In addition, water alone does not provide adequate protection against boiling or freezing.

i04040409

## Capacities (Refill)

**SMCS Code:** 7560

Table 32

| Approximate Refill Capacities<br>Common for All B3 Series |        |            |                  |
|---|--------|------------|------------------|
| Compartment or System                                     | Liters | US Gallons | Imperial Gallons |
| Hydraulic Tank  | 35.0   | 9.3        | 7.7              |

Table 33

| Approximate Refill Capacities<br>216B3 |        |            |                  |
|--|--------|------------|------------------|
| Compartment or System                  | Liters | US Gallons | Imperial Gallons |
| Engine Crankcase                       | 10     | 2.6        | 2.2              |
| Fuel Tank                              | 58     | 15.4       | 12.8             |
| Cooling System                         | 9      | 2.4        | 2.0              |
| Each Drive Chain Box                   | 6      | 1.6        | 1.3              |

Table 34

| Approximate Refill Capacities<br>226B3 |        |            |                  |
|--|--------|------------|------------------|
| Compartment or System                  | Liters | US Gallons | Imperial Gallons |
| Engine Crankcase                       | 10     | 2.6        | 2.2              |
| Fuel Tank                              | 58     | 15.4       | 12.8             |
| Cooling System                         | 10.5   | 2.8        | 2.3              |
| Each Drive Chain Box                   | 6      | 1.6        | 1.3              |

Table 35

| Approximate Refill Capacities<br>242B3 |        |            |                  |
|--|--------|------------|------------------|
| Compartment or System                  | Liters | US Gallons | Imperial Gallons |
| Engine Crankcase                       | 9      | 2.6        | 2.2              |

(continued)

Maintenance Section  
S·O·S Information

(Table 35, contd)

|                      |      |      |      |
|----------------------|------|------|------|
| Fuel Tank            | 58   | 15.4 | 12.8 |
| Cooling System       | 12.5 | 2.8  | 2.3  |
| Each Drive Chain Box | 8    | 2.1  | 1.8  |

Table 36

| Approximate Refill Capacities<br>236B3 |        |            |                  |
|--|--------|------------|------------------|
| Compartment or System                  | Liters | US Gallons | Imperial Gallons |
| Engine Crankcase                       | 9      | 2.4        | 2.0              |
| Fuel Tank                              | 90.0   | 23.8       | 19.8             |
| Cooling System                         | 12.5   | 3.3        | 2.7              |
| Each Drive Chain Box                   | 7.5    | 2.0        | 1.6              |

Table 37

| Approximate Refill Capacities<br>252B3 |        |            |                  |
|--|--------|------------|------------------|
| Compartment or System                  | Liters | US Gallons | Imperial Gallons |
| Engine Crankcase                       | 9      | 2.4        | 2.0              |
| Fuel Tank                              | 90.0   | 23.8       | 19.8             |
| Cooling System                         | 12.5   | 3.3        | 2.7              |
| Each Drive Chain Box                   | 8      | 2.1        | 1.8              |

Table 38

| Approximate Refill Capacities<br>247B3 |        |            |                  |
|--|--------|------------|------------------|
| Compartment or System                  | Liters | US Gallons | Imperial Gallons |
| Engine Crankcase                       | 10     | 2.6        | 2.2              |
| Fuel Tank                              | 62     | 16.4       | 13.6             |
| Cooling System                         | 10     | 2.6        | 2.2              |
| Each Final Drive                       | 1.0    | 0.26       | 0.22             |

Table 39

| Approximate Refill Capacities<br>257B3 |        |            |                  |
|--|--------|------------|------------------|
| Compartment or System                  | Liters | US Gallons | Imperial Gallons |
| Engine Crankcase                       | 9      | 2.4        | 2.0              |
| Cooling System                         | 12.5   | 3.3        | 2.8              |
| Each Final Drive                       | 1.0    | 0.26       | 0.22             |
| Fuel Tank                              | 84     | 22.2       | 18.5             |

Table 40

| Approximate Refill Capacities<br>259B3 |        |            |                  |
|--|--------|------------|------------------|
| Compartment or System                  | Liters | US Gallons | Imperial Gallons |
| Engine Crankcase                       | 9      | 2.4        | 2.0              |
| Cooling System                         | 12.5   | 3.3        | 2.8              |
| Each Final Drive                       | 1.0    | 0.26       | 0.22             |
| Fuel Tank                              | 89     | 23.5       | 19.6             |

Table 41

| Track Roller Frame Approximate Refill Capacities<br>259B3 |             |
|---|-------------|
| Compartment or System                                     | Milliliters |
| Track Roller  | 240 ± 12 ml |
| Idler - Single Flange                                     | 349 ± 15 ml |
| Idler - Dual Flange                                       | 354 ± 15 ml |

i07445339

## S·O·S Information

**SMCS Code:** 1000; 7000; 7542-008

S·O·S Services is a highly recommended process for Cat customers to use in order to minimize owning and operating cost. Customers provide oil samples, coolant samples, and other machine information. The dealer uses the data in order to provide the customer with recommendations for management of the equipment. In addition, S·O·S Services can help determine the cause of an existing product problem.

Refer to Special Publication, SEBU6250, "Caterpillar Machine Fluid Recommendations" for detailed information concerning S·O·S Services.

The effectiveness of S·O·S Services is dependent on timely submission of the sample to the laboratory at recommended intervals.

Refer to the Operation and Maintenance Manual, "Maintenance Interval Schedule" for a specific sampling location and a service hour maintenance interval.

Consult your Cat dealer for complete information and assistance in establishing an S·O·S program for your equipment.

# Maintenance Support

i04564699

## Service Interval Chart

**SMCS Code:** 7000

Refer to the following service interval charts and service intervals for additional maintenance information.

**216B3, 226B3, and 236B3**

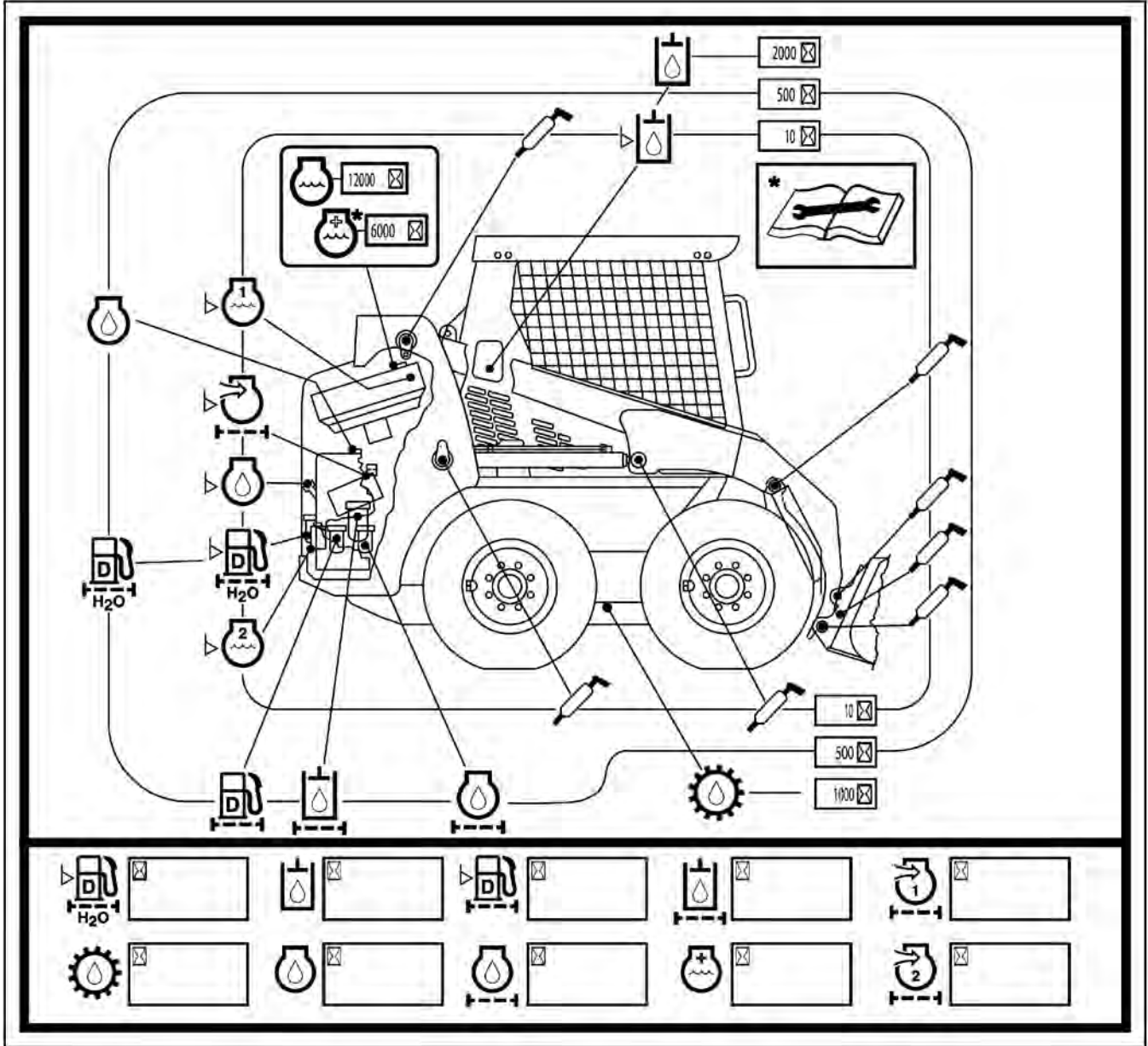

Illustration 167

g01386832

**242B3, and 252B3**





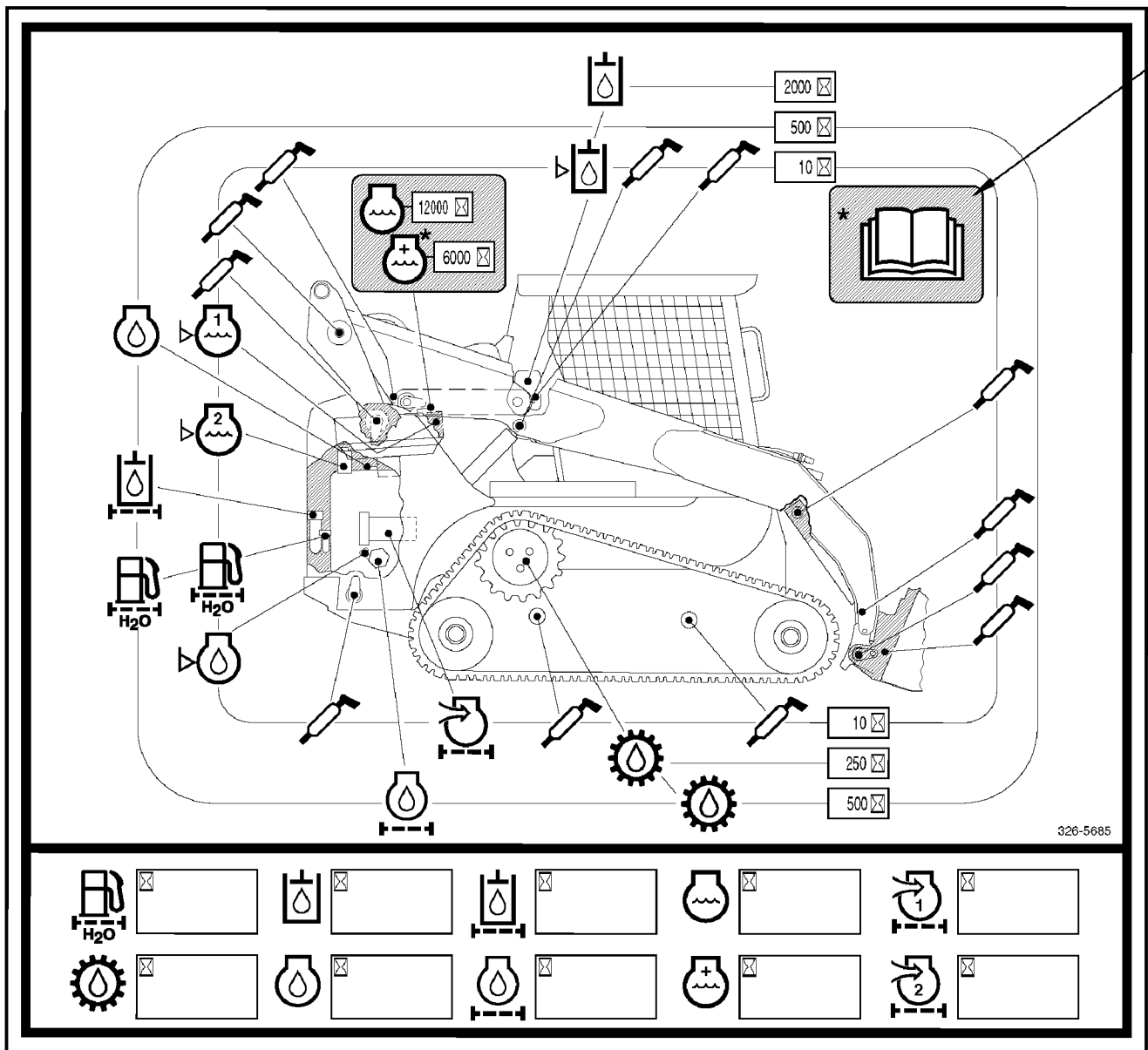

326-5685

Illustration 170

g02125919

### Service Intervals



**Coolant additive** – Add the extender to the extended life coolant after every 6000 service hours or every 3 years.



**Coolant level (radiator)** – Check the coolant level in the radiator at the sight gauge after every 10 service hours or at the end of each day.



**Coolant level (reservoir)** – Check the coolant level in the coolant reservoir after every 10 service hours or at the end of each day.



**Cooling system coolant** – Change the ELC (Extended Life Coolant) after every 12,000 hours or every 6 years.



**Drive Chain Oil** – Check the drive chain case oil after every 500 service hours. Change the oil for the drive chain case after every 1,000 hours or every 6 months.



**Final Drive Oil** – Check the final drive oil after every 250 service hours. Change the final drive oil after the initial 250 service hours. Change the oil for the final drive after every 500 hours.



**Engine air filter primary element** – Clean the primary air filter element or replace the primary air filter element. The alert indicator for the air filter indicates when servicing is necessary.



**Engine air filter secondary element** – Replace the secondary air filter element with every third change of the primary air filter element. Replace the secondary air filter element, if necessary, before service hour requirement.



**Engine oil level check** – Check the engine oil level after every 10 service hours or at the end of each day.



**Engine oil** – Change the engine oil after every 500 service hours or every year.



**Engine oil filter** – Change the engine oil after every 500 service hours or every year.



**Fuel System Water Separator** – Drain the water separator after every 10 service hours or at the end of each day.



**Fuel System Filter/Water Separator Element** – Replace the filter after every 500 service hours or every 3 months.



**Fuel System Filter** – Replace the filter after every 500 service hours or every 6 months on C2.2 engines.



**Grease zerk** – Lubricate the designated locations after every 10 service hours or at the end of each day.



**Hydraulic oil filter** – Change the filter after every 500 service hours or every 3 months.



**Hydraulic oil level check** – Check the hydraulic oil level at the sight gauge after every 10 service hours or at the end of each day.



**Hydraulic oil** – Change the hydraulic oil after every 2000 service hours or every year.

i07746333

## Welding on Machines and Engines with Electronic Controls

**SMCS Code:** 1000; 7000

Do not weld on any protective structure. If it is necessary to repair a protective structure, contact your Cat dealer.

Proper welding procedures are necessary to avoid damage to the electronic controls and to the bearings. When possible, remove the component that must be welded from the machine or the engine and then weld the component. If you must weld near an electronic control on the machine or the engine, temporarily remove the electronic control to prevent heat related damage. The following steps should be followed to weld on a machine or an engine with electronic controls.

1. Turn off the engine. Place the engine start switch in the OFF position.
2. If equipped, turn the battery disconnect switch to the OFF position. If there is no battery disconnect switch, remove the negative battery cable at the battery.

### NOTICE

Do NOT use electrical components (ECM or sensors) or electronic component grounding points for grounding the welder.

3. Clamp the ground cable from the welder to the component that will be welded. Place the clamp as close as possible to the weld. Make sure that the electrical path from the ground cable to the component does not go through any bearing. Use this procedure to reduce the possibility of damage to the following components:
  - Bearings of the drive train
  - Hydraulic components
  - Electrical components
  - Other components of the machine
4. Protect any wiring harnesses and components from the debris and the spatter which is created from welding.

5. Use standard welding procedures to weld the materials together.

i07776981

## Maintenance Interval Schedule

**SMCS Code:** 7000

Ensure that all safety information, warnings, and instructions are read and understood before any operation or any maintenance procedures are performed.

The user is responsible for the performance of maintenance. All adjustments, the use of proper lubricants, fluids, filters, and the replacement of components due to normal wear and aging are included. Failure to adhere to proper maintenance intervals and procedures may result in diminished performance of the product and/or accelerated wear of components.

Use mileage, fuel consumption, service hours, or calendar time, WHICH EVER OCCURS FIRST, in order to determine the maintenance intervals. Products that operate in severe operating conditions may require more frequent maintenance. Refer to the maintenance procedure for any other exceptions that may change the maintenance intervals.

**Note:** Before each consecutive interval is performed, all maintenance from the previous interval must be performed.

**Note:** If Cat HYDO Advanced hydraulic oils are used, the hydraulic oil change interval is extended to 3000 hours. S·O·S services may extend the oil change even longer. Consult your Cat dealer for details.

### When Required

|  |     |
|--|-----|
| “ Air Conditioner Condenser - Clean” . . . . .                 | 157 |
| “ Battery or Battery Cable - Inspect/Replace” . . . . .        | 158 |
| “ Blade Frame - Adjust” . . . . .                              | 162 |
| “ Bucket Cutting Edges - Inspect/Replace” . . . . .            | 165 |
| “ Bucket Tips - Inspect/Replace” . . . . .                     | 165 |
| “ Cab Air Filter - Clean/Replace” . . . . .                    | 166 |
| “ Engine Air Filter Primary Element - Clean/Replace” . . . . . | 176 |
| “ Engine Air Filter Secondary Element - Replace” . . . . .     | 178 |
| “ Fuel System Priming Pump - Operate” . . . . .                | 191 |
| “ Fuel Tank Cap - Clean” . . . . .                             | 192 |
| “ Fuel Tank Water and Sediment - Drain” . . . . .              | 192 |
| “ Fuses - Replace” . . . . .                                   | 193 |
| “ Headlights - Adjust” . . . . .                               | 196 |

|  |     |
|--|-----|
| “Lower Machine Frame - Clean” . . . . .                      | 201 |
| “ Oil Filter - Inspect” . . . . .                            | 201 |
| “ Radiator Core - Clean” . . . . .                           | 202 |
| “ Sprocket - Inspect” . . . . .                              | 205 |
| “ Track (Rubber) - Remove/Replace” . . . . .                 | 213 |
| “ Track (Rubber) - Remove/Replace” . . . . .                 | 212 |
| “ Window Washer Reservoir - Fill” . . . . .                  | 217 |
| “ Window Wiper - Inspect/Replace” . . . . .                  | 217 |
| “ Windows - Clean” . . . . .                                 | 217 |
| “ Work Tool Guard and Reflector - Inspect/Replace” . . . . . | 220 |

### Every 10 Service Hours or Daily

|   |     |
|---|-----|
| “ Air Cleaner Dust Valve - Clean/Inspect” . . . . .                         | 157 |
| “ Axle Bearings - Lubricate” . . . . .                                      | 158 |
| “ Axle Bearings - Lubricate” . . . . .                                      | 157 |
| “ Backup Alarm - Test” . . . . .  | 158 |
| “ Bogie and Idler - Inspect/Replace” . . . . .                              | 163 |
| “ Cooling System Level - Check” . . . . .                                   | 170 |
| “ Engine Compartment - Inspect/Clean” . . . . .                             | 179 |
| “ Engine Oil Level - Check” . . . . .                                       | 181 |
| “ Equipment Lowering Control Valve - Check” . . . . .                       | 186 |
| “ Fuel System Primary Filter (Water Separator) - Drain” . . . . .           | 189 |
| “ Hydraulic System Oil Level - Check ” . . . . .                            | 200 |
| “ Lift Arm and Cylinder Linkage - Lubricate” . . . . .                      | 200 |
| “ Quick Coupler - Clean/Inspect” . . . . .                                  | 202 |
| “ Seat Belt - Inspect” . . . . .  | 204 |
| “ Sprocket - Inspect” . . . . .   | 205 |
| “ Sprocket Retaining Nuts - Check” . . . . .                                | 208 |
| “ Tilt Cylinder Bearings and Bucket Linkage Bearings - Lubricate” . . . . . | 209 |
| “ Tire Inflation - Check” . . . . .   | 209 |
| “ Track (Rubber) - Inspect/Adjust” . . . . .                                | 211 |
| “ Track - Inspect/Adjust” . . . . .   | 214 |
| “ Track Roller and Idler - Inspect/Replace” . . . . .                       | 216 |
| “ Wheel Nuts - Tighten” . . . . .   | 216 |

|   |     |
|---|-----|
| “ Work Tool - Lubricate” . . . . .                | 218 |
| “ Work Tool Mounting Bracket - Inspect” . . . . . | 221 |

### **Initial 250 Service Hours**

|                                       |     |
|---------------------------------------|-----|
| “ Final Drive Oil - Change” . . . . . | 186 |
|---------------------------------------|-----|

### **Every 250 Service Hours**

|  |     |
|--|-----|
| “ Final Drive Oil Level - Check” . . . . . | 187 |
| “ Engine Oil Sample - Obtain” . . . . .    | 182 |

### **Every 250 Service Hours or Monthly**

|   |     |
|---|-----|
| “ Belts - Inspect/Adjust/Replace” . . . . . | 159 |
| “ Belts - Inspect/Adjust/Replace” . . . . . | 159 |

### **Every 500 Service Hours**

|  |     |
|--|-----|
| “Cooling System Coolant Sample (Level 1) - Obtain” . . . . . | 169 |
| “ Final Drive Oil - Change” . . . . .                        | 186 |
| “ Hydraulic System Oil Sample - Obtain” . . . . .            | 200 |

### **Every 500 Service Hours or 3 Months**

|   |     |
|---|-----|
| “ Drive Chain Case Oil - Check” . . . . .       | 173 |
| “ Drive Chain Tension - Check/Adjust” . . . . . | 174 |

### **Every 500 Service Hours or 6 Months**

|   |     |
|---|-----|
| “ Fuel System Filter (In-Line) - Replace” . . . . .                         | 188 |
| “ Fuel System Primary Filter (Water Separator) Element - Replace” . . . . . | 190 |
| “ Hydraulic System Oil Filter - Replace” . . . . .                          | 199 |

### **Every 500 Service Hours or 1 Year**

|   |     |
|---|-----|
| “ Engine Oil and Filter - Change” . . . . . | 182 |
|---|-----|

|   |     |
|---|-----|
| “ Engine Oil and Filter - Change” . . . . . | 184 |
|---|-----|

### **Every 1000 Service Hours**

|  |     |
|--|-----|
| “ Engine Valve Lash - Check” . . . . . | 186 |
|--|-----|

### **Every 1000 Service Hours or 6 Months**

|  |     |
|--|-----|
| “ Drive Chain Case Oil - Change” . . . . .   | 172 |
| “ Engine Crankcase Breather - Clean” . . . . .   | 179 |
| “ Rollover Protective Structure (ROPS) and Falling Object Protective Structure (FOPS) - Inspect” . . . . . | 204 |

### **Every 1000 Service Hours or 1 Year**

|  |     |
|--|-----|
| “ Sprocket Sleeve - Inspect” . . . . . | 208 |
|--|-----|

### **Every 2000 Service Hours**

|   |     |
|---|-----|
| “Refrigerant Dryer - Replace” . . . . . | 203 |
|---|-----|

### **Every 2000 Service Hours or 1 Year**

|  |     |
|--|-----|
| “ Fuel Injection Timing - Check” . . . . . | 188 |
|--|-----|

“Hydraulic System Oil - Change” . . . . . 196

**Every Year**

“Cooling System Coolant Sample (Level 2) - Obtain” . . . . . 170

**Every 3000 Service Hours or 2 Years**

“Cooling System Water Temperature Regulator - Replace” . . . . . 171

**Every 3 Years**

“Seat Belt - Replace” . . . . . 205

**Every 3 Years After Date of Installation or Every 5 Years After Date of Manufacture**

“Seat Belt - Replace” . . . . . 205

**Every 6000 Service Hours or 3 Years**

“Cooling System Coolant Extender (ELC) - Add” . . . . . 168

**Every 12 000 Service Hours or 6 Years**

“Cooling System Coolant (ELC) - Change” . . . . . 166

i03318742

i03879882

## Air Cleaner Dust Valve - Clean/Inspect

**SMCS Code:** 1051-571-VL

Service the air filter elements when the alert indicator for air filter restriction lights. Refer to Operation and Maintenance Manual, "Alert Indicators" for information about the indicator.

1. Open the engine access door.
2. The air filter housing is located in the engine compartment.

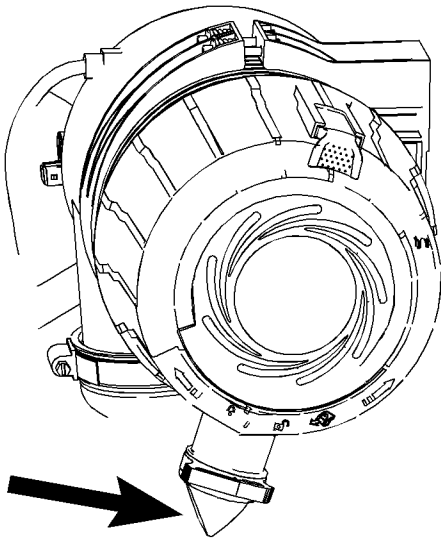

Illustration 171

g01433144

3. Check the air cleaner dust valve after every ten service hours or at the end of each day. Actuate the valve by squeezing the lips of the valve in order to remove any accumulated debris.

## Air Conditioner Condenser - Clean (If Equipped)

**SMCS Code:** 1805-070

### **WARNING**

**Personal injury can result from air pressure.**

**Personal injury can result without following proper procedure. When using pressure air, wear a protective face shield and protective clothing.**

**Maximum air pressure at the nozzle must be less than 205 kPa (30 psi) for cleaning purposes.**

The air conditioner condenser is located behind the engine on the frame.

Open the engine access door.

Inspect the air conditioner condenser for the following conditions:

- Damaged fins
- Buildup of debris
- Plugged areas

Remove any debris. Clean the condenser with low pressure air or low pressure water. The maximum water pressure for cleaning purposes must be less than 275 kPa (40 psi).

i02772986

## Axle Bearings - Lubricate

**SMCS Code:** 3282-086-BD

**S/N:** KB31-Up

**S/N:** B7H1-Up

**S/N:** ESL1-Up

**S/N:** TSL1-Up

i02580453

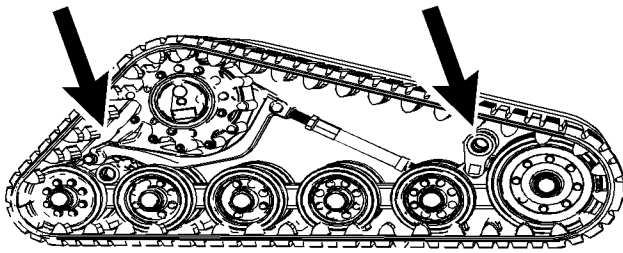

Illustration 172

g01387575

Apply lubricant to the grease fittings for the rear axle bearings and the front axle bearings.

Repeat the process for the opposite side of the machine.

i03898482

## Axle Bearings - Lubricate

**SMCS Code:** 3282-086-BD

**S/N:** HR21-Up

**S/N:** PWK1-Up

**S/N:** DXZ1-Up

**S/N:** YYZ1-Up

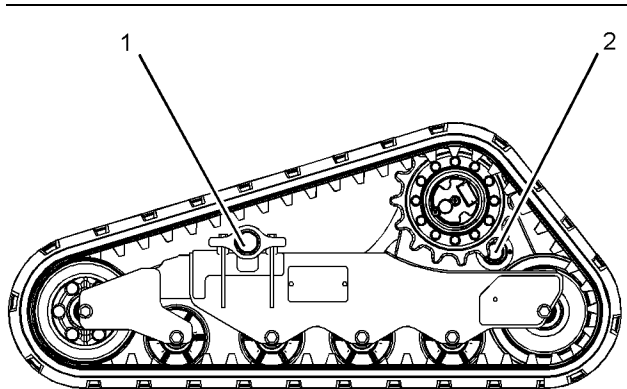

Illustration 173

g02142341

Apply lubricant to all grease fittings.

(1) Front pivot

(2) Rear pivot

Repeat the process for the opposite side of the machine.

## Backup Alarm - Test

**SMCS Code:** 7406-081

To prevent injury, make sure that no people are working on the machine or near the machine. To prevent injury, keep the machine under control at all times.

1. Get into the operator's seat. Fasten the seat belt and pull the armrests downward.
2. Start the engine.
3. Disengage the parking brake.
4. Move the joystick control to the REVERSE position.

The backup alarm should sound immediately. The backup alarm should continue to sound until the joystick control is returned to the NEUTRAL position or to the FORWARD position.

i04395699

## Battery or Battery Cable - Inspect/Replace

**SMCS Code:** 1401-561; 1401-510; 1401-040; 1402-510; 1402-040

1. Turn the engine start switch to the OFF position. Turn all switches to the OFF position.
2. Disconnect the negative battery cable from the starter.

**Note:** Do not allow the disconnected battery cable to contact the frame of the machine.

3. Disconnect the negative battery cable at the battery.
4. Perform the necessary repairs. Replace the cable or the battery, as needed.
5. Connect the negative battery cable at the battery.
6. Connect the battery cable to the starter of the machine.
7. Install the engine start switch key.

Repeat the process for the positive battery cable.

## Battery - Recycle

Always recycle a battery. Never discard a battery.

Always return used batteries to one of the following locations:

- A battery supplier
- An authorized battery collection facility
- Recycling facility

i06743882

## Belts - Inspect/Adjust/Replace

**SMCS Code:** 1357-025; 1357-510; 1357-040

**S/N:** AS21-Up

**S/N:** HR21-Up

**S/N:** CD31-Up

**S/N:** KB31-Up

**S/N:** SNA1-Up

**S/N:** MWD1-Up

**S/N:** PWK1-Up

**S/N:** ESL1-Up

**S/N:** TSL1-Up

**S/N:** JXM1-Up

**S/N:** DSN1-Up

**S/N:** DXZ1-Up

If a new belt is installed, check the belt adjustment after 30 minutes of operation. A belt is considered to be used after 30 minutes of operation.

1. Stop the engine to inspect the belt.
2. Open the engine access door. Refer to Operation and Maintenance Manual, "Access Doors and Covers".

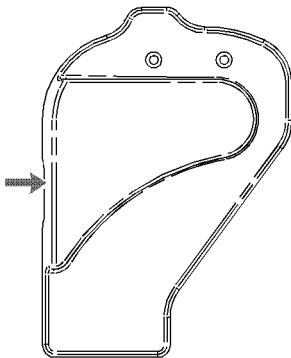

Illustration 174

g01017605

3. Remove the guard for the V-belt.

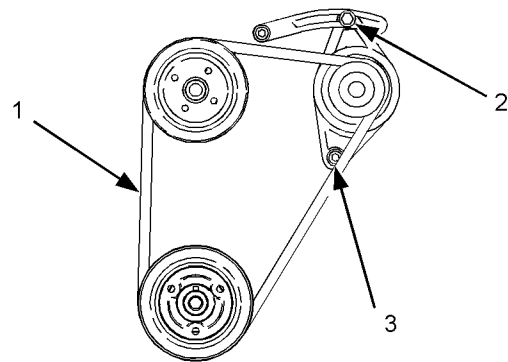

Illustration 175

g01017632

4. Inspect the condition of the belt (1) and the adjustment of the belt. The belt should deflect 10 mm (0.39 inch) under a straight pull of 44 N (10 lb). This measurement should be taken between the alternator pulley and the crankshaft pulley.

**Note:** A 144 - 0235 Borroughs Belt Tension Gauge may be used to measure belt tension. This measurement should be taken between the alternator pulley and the crankshaft pulley. Refer to the following table for belt tension.

Table 42

| Belt Tension Initial        | Belt Tension Used          |
|-----------------------------|----------------------------|
| 400 to 489 N (90 to 110 lb) | 267 to 356 N (60 to 80 lb) |

5. Loosen the mounting bolt (2). Loosen the adjusting locknut (3).
6. Move the alternator until the correct tension is reached.
7. Tighten the adjusting locknut. Tighten the mounting bolt.
8. Recheck the belt deflection. If the amount of deflection is incorrect, repeat step 4 to step 7.
9. Install the guard for the V-belt.
10. Close the engine access door.

i06743965

## Belts - Inspect/Adjust/Replace

**SMCS Code:** 1357-025; 1357-510; 1357-040

**S/N:** A9H1-Up

**S/N:** B7H1-Up

**S/N:** TNK1-Up

**S/N:** SRS1–Up

**S/N:** YYZ1–Up

If a new belt is installed, check the belt adjustment after 30 minutes of operation. A belt is considered to be used after 30 minutes of operation.

## Belts

1. Stop the engine to inspect the belt.
2. Open the engine access door. Refer to Operation and Maintenance Manual, "Access Doors and Covers".

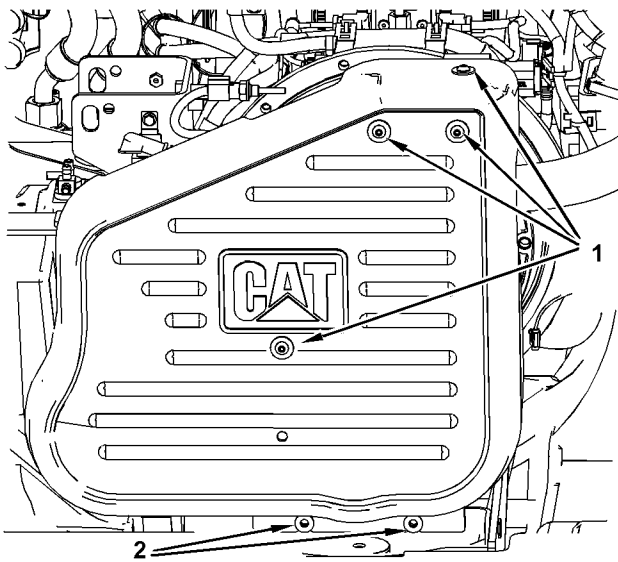

Illustration 176

g01209498

3. Remove the four bolts (1) on the top of the guard. Loosen the two bolts (2) on the bottom of the guard.
4. Slide the guard upward from bottom bolts. Remove the guard for the V-belt.

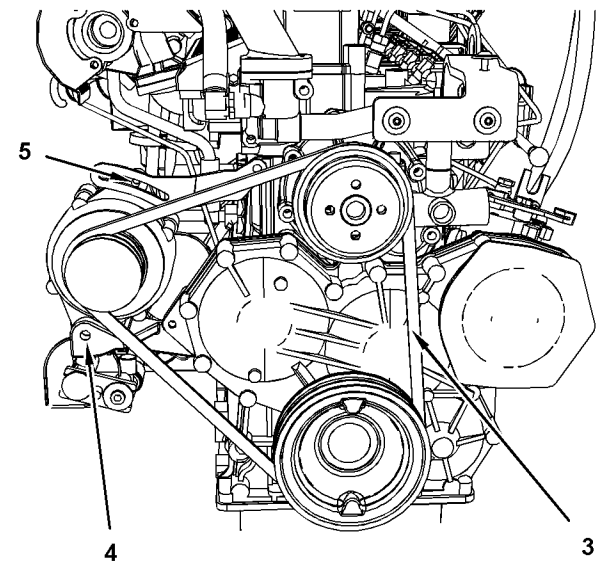

Illustration 177

g01209499

5. Inspect the condition of the belt (3) and the adjustment of the belt. The belt should deflect 10 mm (0.39 inch) under a straight pull of 44 N (10 lb). This measurement should be taken between the alternator pulley and the crankshaft pulley.

**Note:** A 144-0235 Borroughs Belt Tension Gauge may be used to measure belt tension. This measurement should be taken between the alternator pulley and the crankshaft pulley. Refer to the following table for belt tension.

Table 43

| Belt Tension Initial        | Belt Tension Used          |
|-----------------------------|----------------------------|
| 400 to 489 N (90 to 110 lb) | 267 to 356 N (60 to 80 lb) |

6. Loosen the mounting bolt (4). Loosen the adjusting locknut (5).
7. Move the alternator until the correct tension is reached.
8. Tighten the adjusting locknut. Tighten the mounting bolt.
9. Recheck the belt deflection. If the amount of deflection is incorrect, repeat step 5 to step 8.

## Air Conditioner (if equipped)

**Note:** If your machine is equipped with an air conditioner, use the same procedure and the same measurements for the belt tension.

1. Inspect the condition of the belt and the adjustment of the belt. The belt should deflect 10 mm (0.39 inch) under a straight pull of 44 N (10 lb). This measurement should be taken between the air conditioner compressor pulley and the crankshaft pulley.

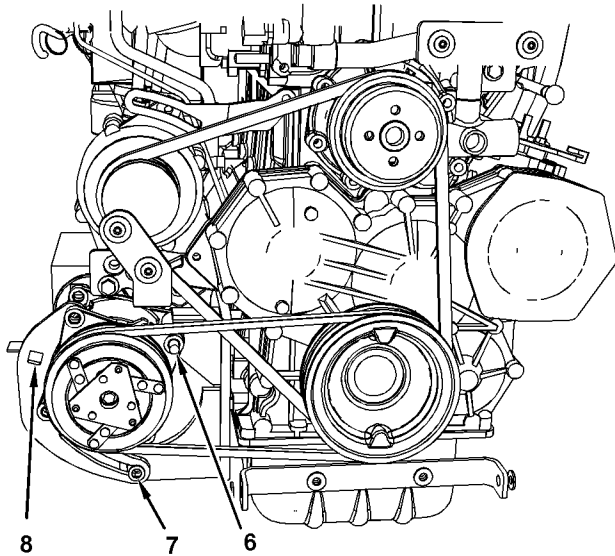

Illustration 178

g01279933

2. Loosen the mounting bolt (6) for the air conditioner compressor. Loosen the adjusting locknut (7) for the air conditioner compressor.
  3. Move the air conditioner compressor until the correct tension is reached.
- Note:** A hole (8) in the bracket has been provided to aid with the adjustment of the tension.
4. Tighten the adjusting locknut. Tighten the mounting bolt.
  5. Recheck the belt deflection. If the amount of deflection is incorrect, repeat step 2 to step 4.

## Finish

1. Apply thread lock compound to the threads on bolts (1).

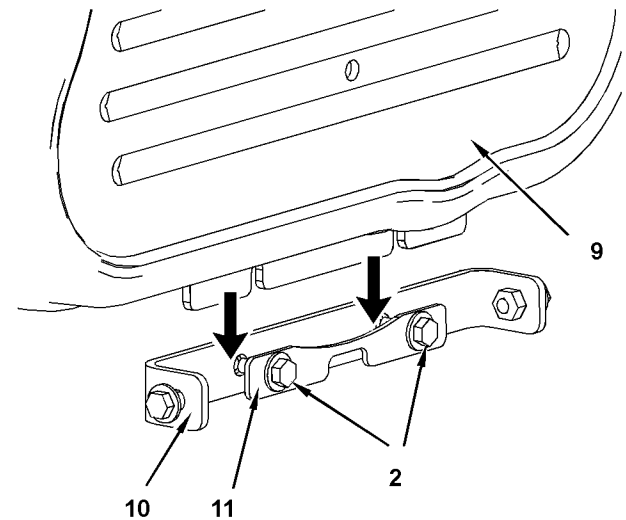

Illustration 179

g01364054

2. Install the guard for the V-belt (9). Ensure that the guard is inserted between the mounting bracket (10) and the spreader plate (11) before you tighten the bolts (2). Tighten the bolts (2) to  $15 \pm 3 \text{ N}\cdot\text{m}$  ( $11 \pm 2 \text{ lb ft}$ ).

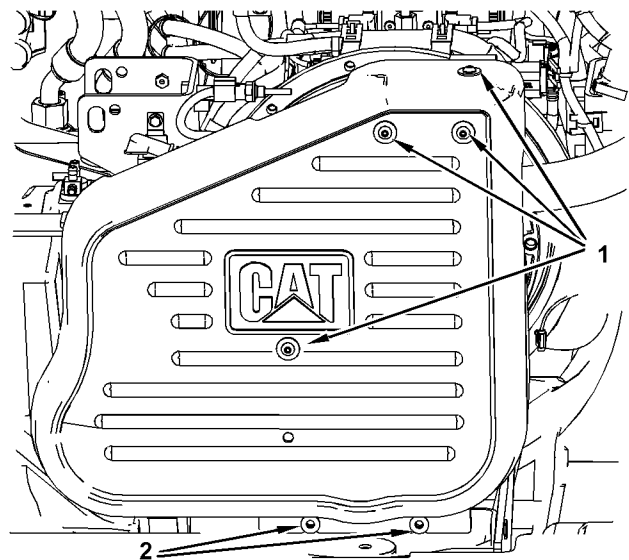

Illustration 180

g01209498

3. Tighten the bolts (1) to  $12 \pm 3 \text{ N}\cdot\text{m}$  ( $9 \pm 2 \text{ lb ft}$ ).

**Note:** Start all the bolts (1) in the holes before you start tightening the bolts. This practice helps align all the holes.

4. Close the engine access door.

i07690426

## Blade Frame - Adjust

SMCS Code: 6060-025-BG

### Height Adjustment

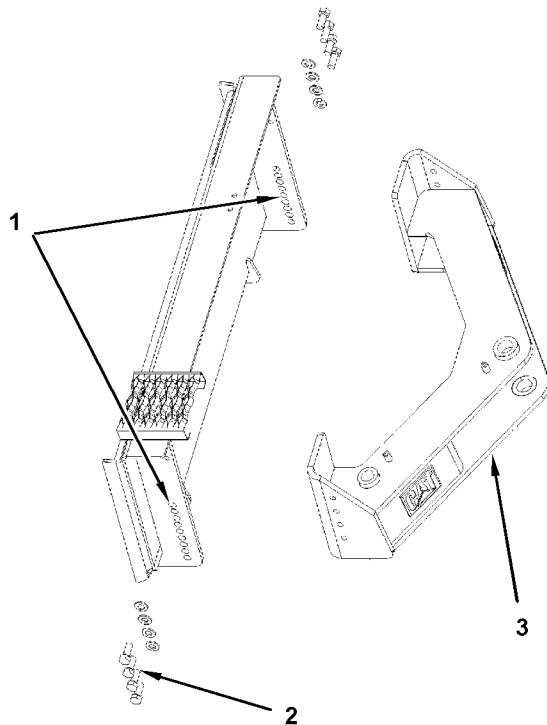

Illustration 181

g01161532

- (1) Height Adjustment for the Frame  
(2) Adjusting Bolts  
(3) Frame

The height of the frame may be adjusted in order to compensate for the wear on the cutting edge. The front portion of the frame needs to be lowered as the cutting edge wears. Remove the bolts (2) and lower the frame (3). Install the bolts. This will keep the blade level with the ground and this will prevent the blade from digging into the ground.

**Note:** In order to properly adjust the blade, the work tool coupler needs to be vertical. The position of the pivot point of the blade is perpendicular to the ground. Follow this procedure in order to ensure that the cutting edge will remain flat on the ground during operation.

### Trunnion Joint

**Note:** The trunnion is a dry joint. Adding grease to the trunnion simply attracts abrasive particles. The tightness of the joint should be monitored. Shims should be removed when the joint becomes too loose. This may be indicated by excessive movement in the blade.

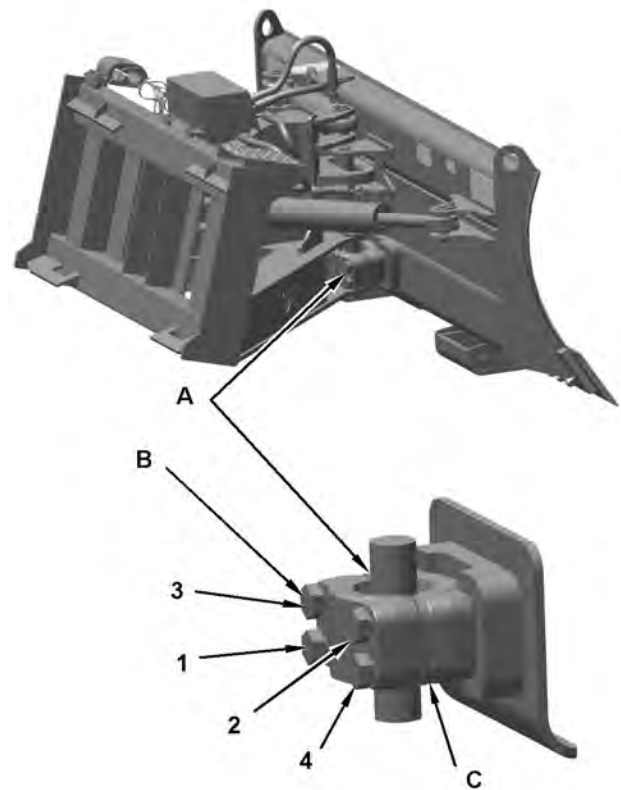

Illustration 182

g06393817

- (A) Trunnion Joint  
(B) Bolts  
(C) Shims

- Remove the four retaining bolts (B) and the cap.
- Remove the necessary shims.
- Replace the cap and bolts.

- The tightening sequence is shown in illustration 182 .
- Torque the bolts to  $530 \pm 70$  N·m ( $391 \pm 52$  lb ft).

**Note:** Some noise is typical and the noise does not indicate a problem.

i07717495

## Bogie and Idler - Inspect/ Replace

**SMCS Code:** 4159-510; 4159-040; 4192-510; 4192-040

**S/N:** KB31–Up

**S/N:** B7H1–Up

**S/N:** ESL1–Up

**S/N:** TSL1–Up

### Inspect

Clean the undercarriage before inspecting the bogies and the idlers.

Inspect the bogies and idlers for damage and wear.

**Note:** Minor damage to the rubber on the bogies and idlers is acceptable. Minor damage includes nicks, cuts, small pieces that are missing, and small grooves. This minor damage is normal and acceptable. Minor damage will not adversely affect machine performance.

The bogies and the idlers should be replaced when the damage to the rubber wheels adversely affects machine performance. Replace the bogies and the idlers when the rubber is worn beyond the minimum specifications that are listed below.

Table 44

| Bogie Wheels and Idler Wheels<br>Wear Limits |                  |                   |
|--|------------------|-------------------|
|  | Minimum Width    | Minimum Thickness |
| 254 mm (10 inch)                             | 48 mm (1.9 inch) | 3 mm (0.12 inch)  |
| 358 mm (14 inch)                             | 48 mm (1.9 inch) | 3 mm (0.12 inch)  |

## Loosen the Track

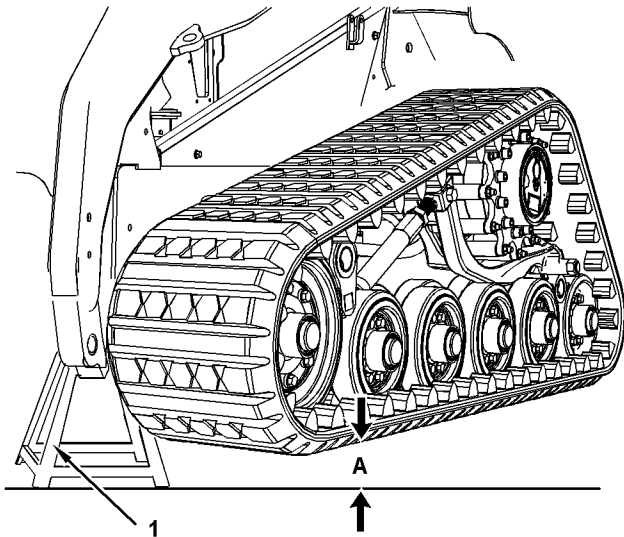

Illustration 183

g01393193

Use an appropriate floor jack in order to lift the machine off the ground. Use appropriate jack stands (1) in order to block up the machine. Raise the machine until tracks are approximately 50 mm (2.0 inches) (A) off the ground.

Loosen the track in order to work on the bogies and idlers. Refer to Operation and Maintenance Manual, "Track - Inspect/Adjust" for the procedure.

**Note:** The track may be removed in the illustrations for clarity.

## Idler wheels

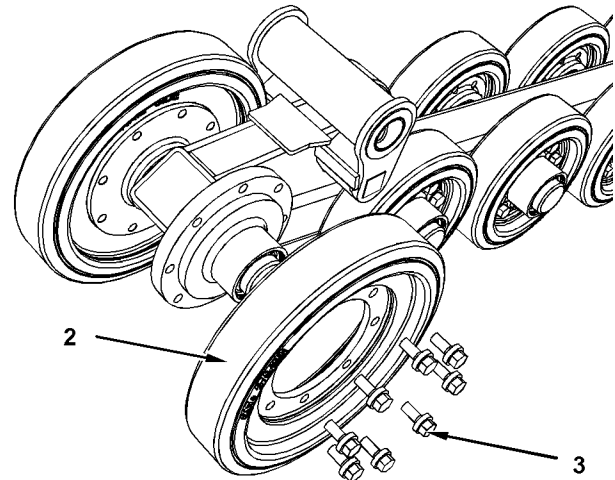

Illustration 184

g01393325

(2) Outer idler wheel  
(3) Bolts and washers for the wheels

1. Remove the bolts (3) and the washers for the outer idler wheel (2).
2. Remove the outer idler wheel.
3. If necessary, remove the bolts and the washers for the inner idler wheel and remove the wheel.

4. Install the wheels. Tighten the bolts to a torque of  $50 \pm 5 \text{ N}\cdot\text{m}$  ( $37 \pm 3.7 \text{ lb ft}$ ). Turn the bolts an additional 45 degrees  $\pm 5$  degrees in the same star pattern.

## Bogie wheels

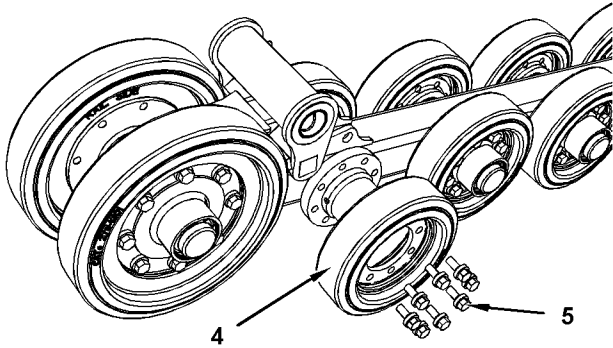

Illustration 185

g01393304

- (4) Bogie Wheel  
(5) Bolts and washers for the wheels

1. Remove the bolts (5) and the washers for the outer bogie wheel (4).
2. Remove the outer bogie wheel.
3. If necessary, remove the bolts and the washers for the inner bogie wheel and remove the wheel.
4. Install the wheels. Tighten the bolts to a torque of  $150 \pm 20 \text{ N}\cdot\text{m}$  ( $110 \pm 15 \text{ lb ft}$ ).

i07331615

## Bucket Cutting Edges - Inspect/Replace

SMCS Code: 6801-510; 6801-040

### WARNING

Personal injury or death can result from bucket falling.

Block the bucket before changing bucket cutting edges.

**Note:** Check for bolts that are loose, damaged, or missing. Tighten loose bolts, and replace and tighten damage or missing bolts. Use caution with damage bolts. There is a chance of the bolts having sharp edges leading to an injury or laceration.

**Note:** The cutting edge may weigh as much as 50 kg (110 lb). Use assistance as needed.

1. Remove all combustible material from the bucket.
2. Lower the lift arms fully. Tilt back the bucket so the bucket cutting edge is accessible.
3. Place blocks under the raised edge of the bucket.
4. Clamp the cutting edge to the bucket.
5. Use a torch or cut-off wheel to remove the nuts.
6. Remove the bolts.
7. Carefully remove the clamps and cutting edge.
8. Clean the contact surfaces.
9. Use the opposite side of the cutting edge, if this side is not worn.
10. Install a new cutting edge, if both edges are worn.
11. Install the bolts.
12. Remove the blocks that are under the bucket.
13. After a few hours of operation, check the bolts for proper torque.

i01764331

## Bucket Tips - Inspect/Replace

SMCS Code: 6805-510; 6805-040

### WARNING

Personal injury or death can result from bucket falling.

Block the bucket before changing bucket cutting edges.

1. Lower the lift arms fully. Tilt back the bucket so that the bucket tips are accessible.
2. Place blocks under the raised edge of the bucket.
3. Remove the mounting bolts. Remove the bucket tips.
4. Clean the mounting surface.
5. Replace the bucket tips.
6. Install the bolts.
7. Remove the blocks that are under the bucket.
8. After a few hours of operation, check the bolts for proper torque.

i01962545

## Cab Air Filter - Clean/Replace (If Equipped)

SMCS Code: 7342-510; 7342-070

### Fresh Air Filter

1. Raise the loader lift arms. Install the brace for the loader lift arm. Refer to Operation and Maintenance Manual, "Loader Lift Arm Brace Operation".

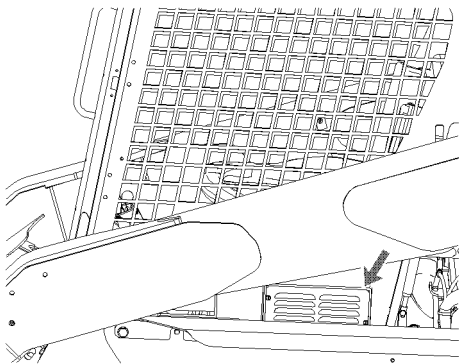

Illustration 186

g01019732

2. Remove the filter cover.
3. Remove the seal from the cover and inspect the seal. If the seal is damaged replace the seal.
4. Remove the air filter element from the cover and clean the filter element with low pressure air. Replace the element if the element is damaged.
5. Install the seal onto the filter cover and install the filter element.
6. Install the filter cover on the machine.

7. Remove the brace for the loader lift arms and return the brace to the stored position. Refer to Operation and Maintenance Manual, "Loader Lift Arm Brace Operation".

### Recirculation Filter

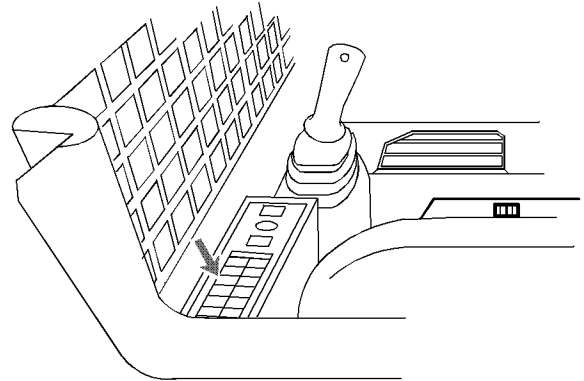

Illustration 187

g01024691

1. Remove the cover in order to access the air filter element.
2. Remove the air filter element and clean the element with soap and water. Replace the element if the element is damaged.
3. Install the element and replace the cover.

i03879985

## Cooling System Coolant (ELC) - Change

SMCS Code: 1395-044-NL

### WARNING

**Pressurized system: Hot coolant can cause serious burn. To open cap, stop engine, wait until radiator is cool. Then loosen cap slowly to relieve the pressure.**

### NOTICE

Mixing ELC with other products will reduce the effectiveness of the coolant.

This could result in damage to cooling system components.

If Caterpillar products are not available and commercial products must be used, make sure they have passed the Caterpillar EC-1 specification for pre-mixed or concentrate coolants and Caterpillar Extender.

**Note:** The machine was shipped from the factory with Extended Life Coolant (ELC) in the cooling system.

For information about the addition of Extender to your cooling system, see the Operation and Maintenance Manual, "Cooling System Coolant (ELC) Extender - Add" or consult your Caterpillar dealer.

Drain the coolant whenever the coolant is dirty or whenever the coolant is foaming.

The radiator cap is located under the radiator guard on the top of the engine compartment.

Allow the machine to cool before you change the coolant.

1. Open the engine access door. Refer to Operation and Maintenance Manual, "Access Doors and Covers".
2. Raise the radiator guard. Refer to Operation and Maintenance Manual, "Radiator Tilting".

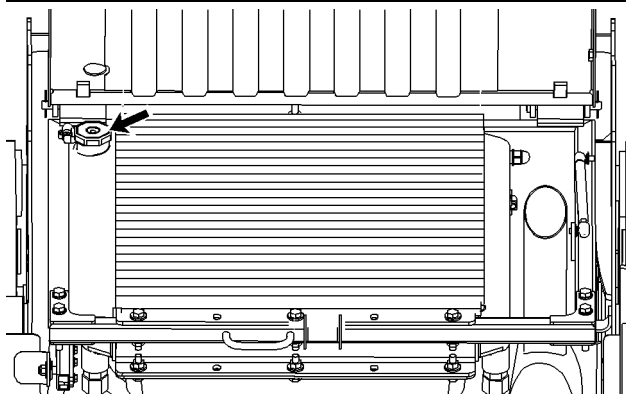

Illustration 188

g00956151

#### Typical Example

3. Slowly loosen the radiator cap in order to relieve system pressure. Remove the radiator cap.

**Note:** The radiator cap is located on the left side of the engine compartment on machines that are equipped with the C2.2 engine. The radiator cap is located on the right side of the engine compartment on machines that are equipped with the C3.4 engine.

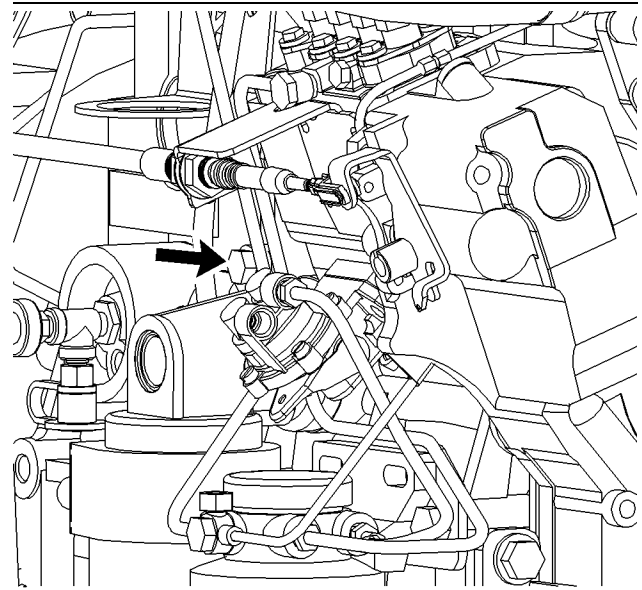

Illustration 189

g00954319

#### Drain Valve for the C2.2 engine

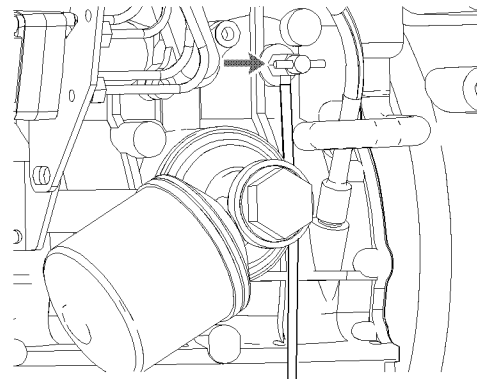

Illustration 190

g01018862

#### Drain Valve for the C3.4 engine

4. Remove the drain plug or open the drain valve (if equipped) and allow the coolant to drain into a suitable container.
5. Install the drain plug or close the drain valve (if equipped).
6. Replace the thermostat. See Operation and Maintenance Manual, "Cooling System Water Temperature Regulator - Replace" for the process for replacing the thermostat.
7. Add the coolant solution. Refer to Operation and Maintenance Manual, "Capacities - (Refill)". Refer to Special Publication, SEBU6250, "Caterpillar Machine Fluids Recommendations".

**Note:** Premix the coolant solution before filling the cooling system. The coolant solution should contain 50 percent coolant and 50 percent distilled water.

**Note:** Add the coolant solution at a maximum rate of five liters per minute. This will reduce the chance of trapping air inside the engine block. A large amount of trapped air can cause localized heating to occur upon start-up. Localized heating may result in engine damage, which may lead to failure of the engine.

8. Start the engine. Run the engine without the radiator cap until the thermostat opens and the coolant level stabilizes.

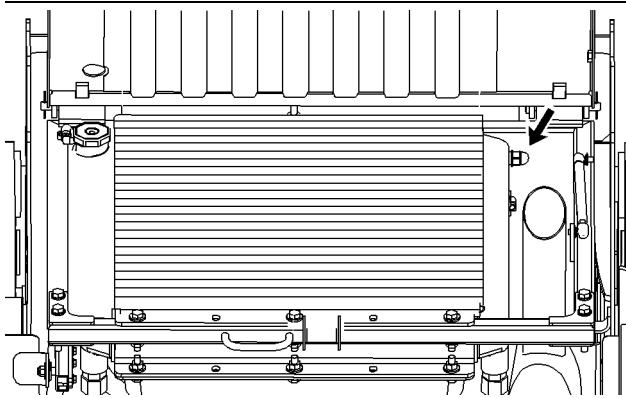

Illustration 191

g00956179

Typical Example

9. Maintain the coolant level in the sight gauge.

**Note:** The sight gauge is located on the right side of the engine compartment on machines that are equipped with the C2.2 engine. The sight gauge is located on the left side of the engine compartment on machines that are equipped with the C3.4 engine.

10. Stop the engine. Inspect the radiator cap and the gasket. Replace the cap if the cap or the gasket is damaged. Install the radiator cap.
11. Pull the radiator guard downward.
12. Close the engine access door.

i03879996

## Cooling System Coolant Extender (ELC) - Add

SMCS Code: 1352-544-NL

### WARNING

**Pressurized system: Hot coolant can cause serious burn. To open cap, stop engine, wait until radiator is cool. Then loosen cap slowly to relieve the pressure.**

When a Caterpillar Extended Life Coolant is used, an extender must be added to the cooling system periodically.

1. Open the engine access door. Refer to Operation and Maintenance Manual, "Access Doors and Covers".
2. Tilt the radiator guard upward. Refer to Operation and Maintenance Manual, "Radiator Tilting".

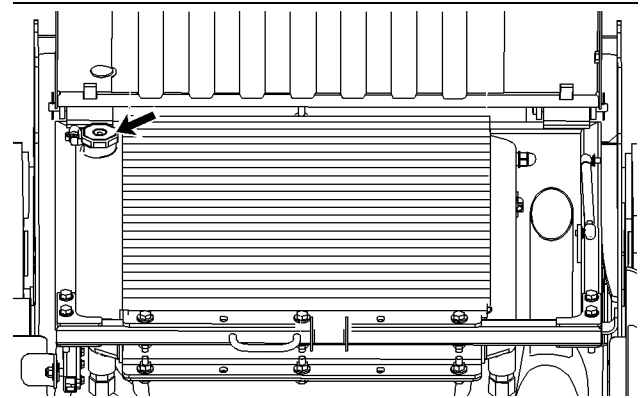

Illustration 192

g00956151

Typical Example

**Note:** The radiator cap is located on the left side of the engine compartment on machines that are equipped with the C2.2 engine. The radiator cap is located on the right side of the engine compartment on machines that are equipped with the C3.4 engine.

3. Slowly loosen the radiator cap in order to relieve system pressure. Remove the radiator cap.
4. If necessary, drain enough coolant from the radiator in order to allow the addition of the coolant additive.
5. Add 0.17 L (0.18 qt) of cooling system additive.
6. Inspect the radiator cap and the gasket. If the cap or the gasket is damaged, replace the cap. Install the radiator cap.

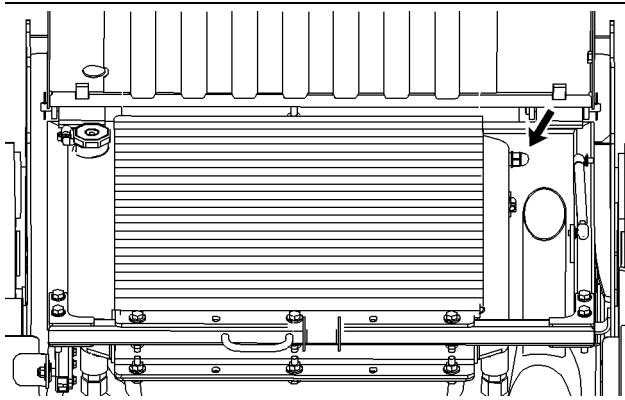

Illustration 193

g00956179

## Typical Example

**Note:** The sight gauge for the coolant level is located on the right side of the engine compartment on machines that are equipped with the C2.2 engine. The sight gauge for the coolant level is located on the left side of the engine compartment on machines that are equipped with the C3.4 engine.

7. Check the coolant level in the sight gauge on the radiator. Maintain the coolant level to the top of the sight gauge with the radiator in the LOWERED position.
8. Tilt the radiator guard downward.
9. Close the engine access door.

For additional information on the addition of extender, see Special Publication, SEBU6250, "Caterpillar Machine Fluids Recommendations".

i03880003

## Cooling System Coolant Sample (Level 1) - Obtain

**SMCS Code:** 1350-008; 1395-008; 7542

### NOTICE

Always use a designated pump for oil sampling, and use a separate designated pump for coolant sampling. Using the same pump for both types of samples may contaminate the samples that are being drawn. This contaminate may cause a false analysis and an incorrect interpretation that could lead to concerns by both dealers and customers.

**Note:** Level 1 results may indicate a need for Level 2 Analysis.

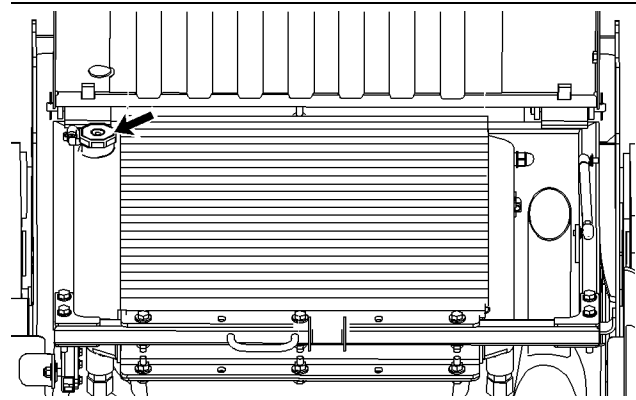

Illustration 194

g00956151

## Typical Example

Refer to the Operation and Maintenance Manual, "Access Doors and Covers" for the location of the service points.

### WARNING

**Pressurized system: Hot coolant can cause serious burn. To open cap, stop engine, wait until radiator is cool. Then loosen cap slowly to relieve the pressure.**

Obtain the sample of the coolant from the radiator. When the system is cool, slowly remove the radiator cap.

**Note:** The radiator cap is located on the left side of the engine compartment on machines that are equipped with the C2.2 engine. The radiator cap is located on the right side of the engine compartment on machines that are equipped with the C3.4 engine.

**Note:** Do not take the sample from the Coolant Overflow Reservoir.

Obtain the sample of the coolant as close as possible to the recommended sampling interval. In order to receive the full effect of S·O·S analysis, you must establish a consistent trend of data. In order to establish a pertinent history of data, perform consistent samplings that are evenly spaced. Supplies for collecting samples can be obtained from your Caterpillar dealer.

Use the following guidelines for proper sampling of the coolant:

- Keep the unused sampling bottles stored in plastic bags.
- Keep the lids on empty sampling bottles until you are ready to collect the sample.
- Complete the information on the label for the sampling bottle before you begin to take the samples.

Maintenance Section  
Cooling System Coolant Sample (Level 2) - Obtain

- Use a designated pump to collect the sample in order to avoid contamination.
- Obtain coolant samples directly from the coolant tank. You should not obtain the samples from any other location.
- Place the sample in the mailing tube immediately after obtaining the sample in order to avoid contamination.
- Never collect samples from the drain for a system.

Submit the sample for Level 1 analysis.

For additional information about coolant analysis, see Special Publication, SEBU6250, "Caterpillar Machine Fluids Recommendations" or consult your Caterpillar dealer.

i03880006

## Cooling System Coolant Sample (Level 2) - Obtain

**SMCS Code:** 1350-008; 1395-008; 7542

### NOTICE

Always use a designated pump for oil sampling, and use a separate designated pump for coolant sampling. Using the same pump for both types of samples may contaminate the samples that are being drawn. This contaminate may cause a false analysis and an incorrect interpretation that could lead to concerns by both dealers and customers.

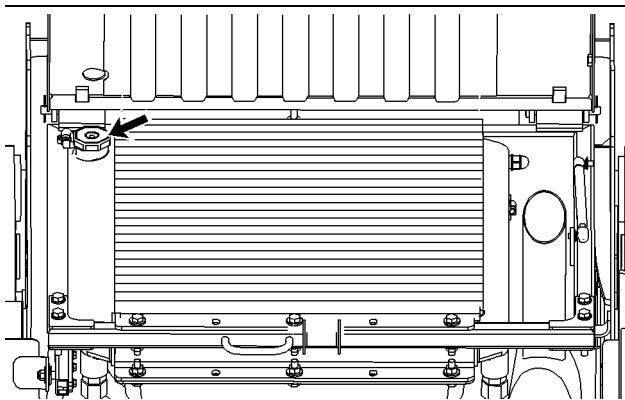

Illustration 195

g00956151

Typical Example

Refer to the Operation and Maintenance Manual, "Access Doors and Covers" for the location of the service points.

### WARNING

**Pressurized system: Hot coolant can cause serious burn. To open cap, stop engine, wait until radiator is cool. Then loosen cap slowly to relieve the pressure.**

Obtain the sample of the coolant from the radiator. When the system is cool, slowly remove the radiator cap.

**Note:** The radiator cap is located on the left side of the engine compartment on machines that are equipped with the C2.2 engine. The radiator cap is located on the right side of the engine compartment on machines that are equipped with the C3.4 engine.

**Note:** Do not take the sample from the Coolant Overflow Reservoir.

Obtain the sample of the coolant as close as possible to the recommended sampling interval. Supplies for collecting samples can be obtained from your Caterpillar dealer.

Refer to Operation and Maintenance Manual, "Cooling System Coolant Sample (Level 1) - Obtain" for the guidelines for proper sampling of the coolant.

Submit the sample for Level 2 analysis.

For additional information about coolant analysis, see Special Publication, SEBU6250, "Caterpillar Machine Fluids Recommendations" or consult your Caterpillar dealer.

i03880033

## Cooling System Level - Check

**SMCS Code:** 1350-040-HX; 1350-535-FLV; 1382-510; 1382-070

### WARNING

**Pressurized system: Hot coolant can cause serious burn. To open cap, stop engine, wait until radiator is cool. Then loosen cap slowly to relieve the pressure.**

1. Open the engine access door. Refer to Operation and Maintenance Manual, "Access Doors and Covers".
2. Tilt the radiator guard upward. Refer to Operation and Maintenance Manual, "Radiator Tilting".

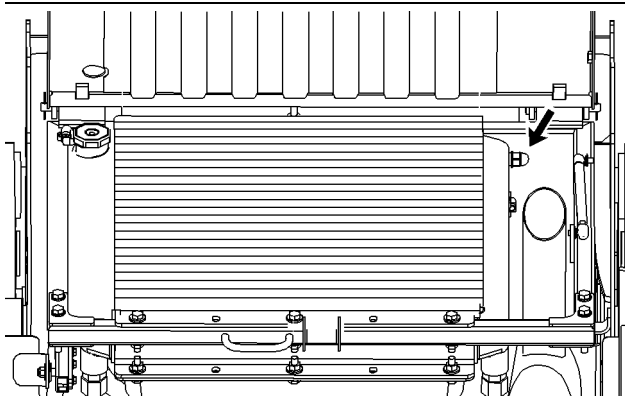

Illustration 196

g00956179

**Note:** The sight gauge for the coolant level is located on the right side of the engine compartment on machines that are equipped with the C2.2 engine. The sight gauge for the coolant level is located on the left side of the engine compartment on machines that are equipped with the C3.4 engine.

3. Maintain the coolant to the top of the sight gauge with the radiator in the LOWERED position.

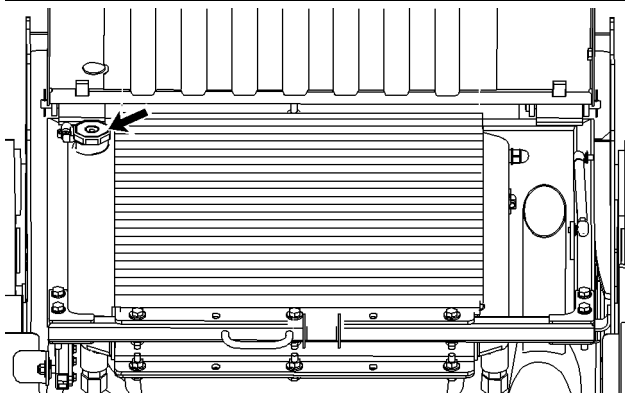

Illustration 197

g00956151

**Note:** The radiator cap is located on the left side of the engine compartment on machines that are equipped with the C2.2 engine. The radiator cap is located on the right side of the engine compartment on machines that are equipped with the C3.4 engine.

4. If you need to add coolant to the radiator, remove the radiator cap slowly in order to relieve system pressure.

**Note:** Inspect the cooling system hoses for any leaks, cracks, or signs of deterioration. Replace any damaged hoses.

5. Inspect the radiator cap and the gasket. Replace the cap if the cap or the gasket is damaged. Install the radiator cap.

6. Tilt the radiator guard downward.

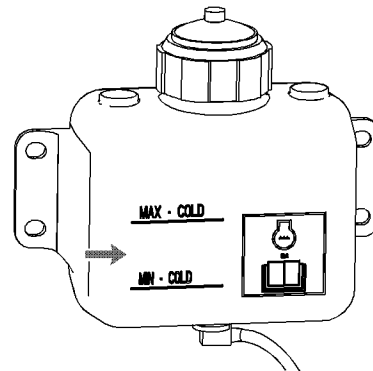

Illustration 198

g01018341

7. The coolant reservoir is located on either the left side of the engine compartment or on the engine access door. Maintain the coolant level in the coolant reservoir between the "MIN" and "MAX" lines.
8. Close the engine access door.

i03880044

## Cooling System Water Temperature Regulator - Replace

**SMCS Code:** 1355-510; 1393-010

Replace the thermostat on a regular basis in order to reduce the chance of unscheduled downtime and of problems with the cooling system. Failure to replace the engine's thermostat on a regularly scheduled basis could cause severe engine damage.

The thermostat should be replaced after the cooling system has been cleaned. Replace the thermostat while the cooling system is completely drained or while the cooling system coolant is drained to a level that is below the thermostat housing.

Caterpillar engines incorporate a shunt design cooling system. It is mandatory to always operate the engine with a thermostat.

1. Open the engine access door. Refer to Operation and Maintenance Manual, "Access Doors and Covers".
2. Drain the coolant from the machine. See Operation and Maintenance Manual, "Cooling System Coolant (ELC) - Change" for the procedure to drain the cooling system.

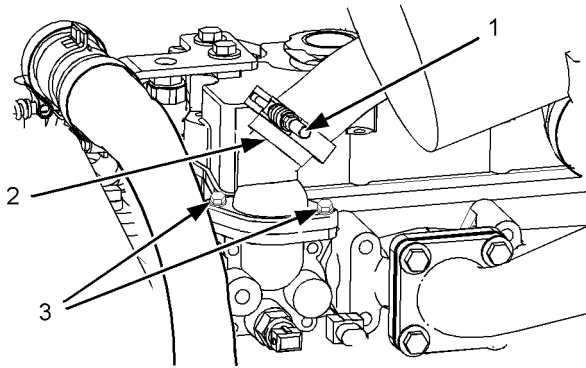

Illustration 199  
C2.2

g01018412

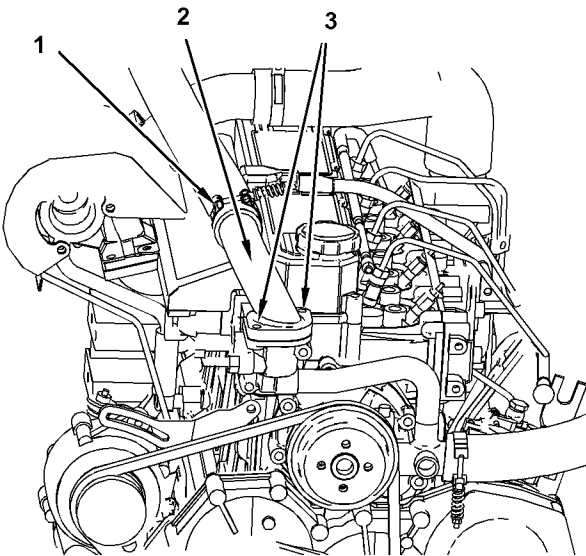

Illustration 200  
C3.4

g01210045

3. Loosen the hose clamp (1) and remove the hose from the thermostat housing assembly (2).
4. Remove the two bolts (3) from the thermostat housing assembly. Remove the thermostat housing assembly.
5. Remove the seal and the thermostat from the thermostat housing assembly.
6. Install a new thermostat and a new seal. Install the thermostat housing assembly on the engine cylinder head.
7. Install the hose. Tighten the hose clamp.

8. Refill the cooling system. Refer to Operation and Maintenance Manual, "Capacities - (Refill)". Refer to Operation and Maintenance Manual, "Cooling System Coolant (ELC) - Change" for information about refilling the cooling system. Refer to Special Publication, SEBU6250, "Caterpillar Machine Fluid Recommendations" for coolant information.
9. Close the engine access door.

i05456650

## Drive Chain Case Oil - Change

SMCS Code: 3261-543-OC; 3261-544-OC

S/N: AS21-Up

S/N: HR21-Up

S/N: CD31-Up

S/N: SNA1-Up

S/N: MWD1-Up

S/N: A9H1-Up

S/N: PWK1-Up

S/N: TNK1-Up

S/N: JXM1-Up

S/N: DSN1-Up

S/N: SRS1-Up

S/N: DXZ1-Up

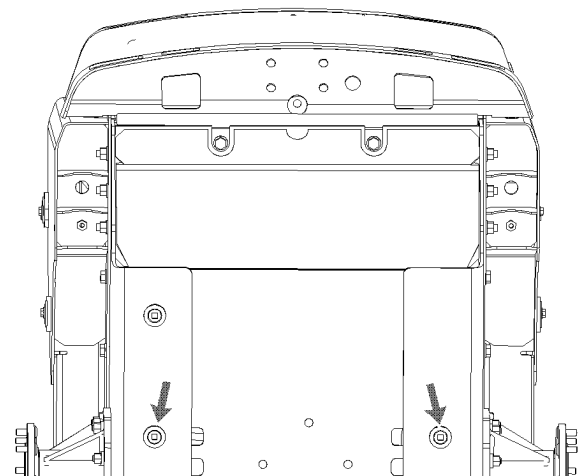

Illustration 201

g01025459

The plugs for the drive chain cases as the plugs are viewed from the underside of the machine.

1. Remove the drain plug for the left drive chain case and the right drive chain case. Allow the oil to drain into a suitable container.
2. Apply 169-5464 Quick Cure Primer and 5P-3413 Pipe Sealant to the threads on the drain plugs. Install the drain plugs.

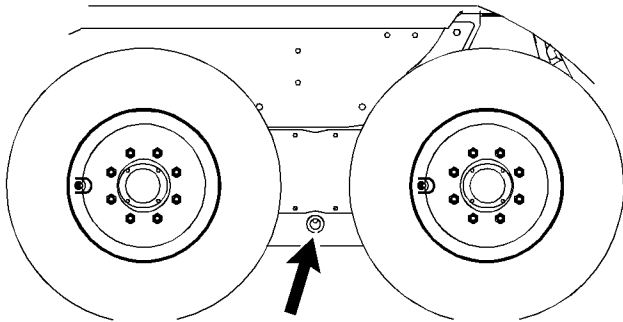

Illustration 202

g03446345

3. Remove the filler plug for the right side drive chain case. Fill the drive chain case with oil to the bottom of the threads on the fill port. Refer to Operation and Maintenance Manual, "Lubricant Viscosities" and Operation and Maintenance Manual, "Refill Capacities".
4. Apply 169-5464 Quick Cure Primer and 5P-3413 Pipe Sealant to the threads on the filler plug. Install the filler plug.
5. Repeat the process for the left side drive chain case.

## Drive Chain Case Breathers

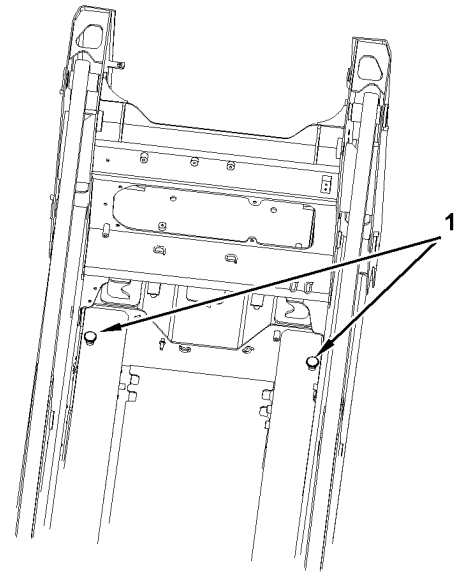

Illustration 203

g01031152

The breathers for the drive chain cases are located underneath the cab (1). Refer to Operation and Maintenance Manual, "Cab Tilting".

Remove the breathers and inspect the breathers when the oil in the drive chain cases is changed. In order to clean the breathers, use solvent and low-pressure air. If the breather is badly plugged, replace the breather.

i02799544

## Drive Chain Case Oil - Check

**SMCS Code:** 3261-535

**S/N:** AS21-Up

**S/N:** HR21-Up

**S/N:** CD31-Up

**S/N:** SNA1-Up

**S/N:** MWD1-Up

**S/N:** A9H1-Up

**S/N:** PWK1-Up

**S/N:** TNK1-Up

**S/N:** JXM1-Up

**S/N:** DSN1-Up

**S/N:** SRS1-Up

**S/N:** DXZ1-Up

Maintenance Section  
Drive Chain Tension - Check/Adjust

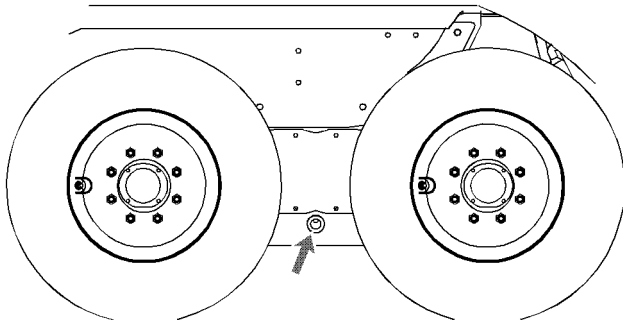

Illustration 204

g01025470

1. Remove the filler plug for the right side drive chain case. The oil level should be at the bottom of the threads on the fill port. If necessary, refer to Operation and Maintenance Manual, "Drive Chain Case Oil - Change" for the proper procedure to add oil.
2. Apply 169-5464 Quick Cure Primer and 5P-3413 Pipe Sealant to the threads on the filler plug. Install the filler plug.
3. Repeat the process for the left side drive chain case.

i03886391

## Drive Chain Tension - Check/Adjust

**SMCS Code:** 3261-535; 3261-025

- S/N:** AS21–Up  
**S/N:** HR21–Up  
**S/N:** CD31–Up  
**S/N:** SNA1–Up  
**S/N:** MWD1–Up  
**S/N:** A9H1–Up  
**S/N:** PWK1–Up  
**S/N:** TNK1–Up  
**S/N:** JXM1–Up  
**S/N:** DSN1–Up  
**S/N:** SRS1–Up  
**S/N:** DXZ1–Up

**Note:** Steel tracks that go over the tires should only be used with pneumatic tires. When you use steel tracks that go over tires or any drive train device except tires, the interval for checking the drive chains should be reduced to every 100 Service Hours. The use of rubber tracks that go over the tires is not recommended.

**Note:** There are four drive chains on the skid steer loader that must be checked and adjusted.

1. Park the machine on level ground and stable ground.
2. Chock the rear tires.
3. Use an appropriate floor jack to lift the front of the machine so that the front tires are off of the ground. Block up the front of the machine with two 1U-9758 Jack Stands.

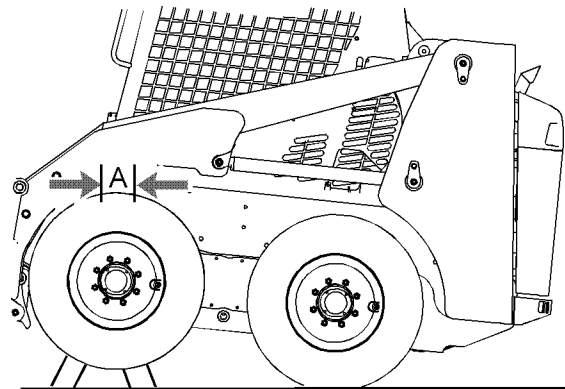

Illustration 205

g01025514

4. Rotate the wheel forward and backward. Measure the total free play (A).

**Note:** If the total free play does not exceed 15 mm (0.6 inch) the chain tension does not need further inspection. If the total free play exceeds 15 mm (0.6 inch), you should continue with the inspection.

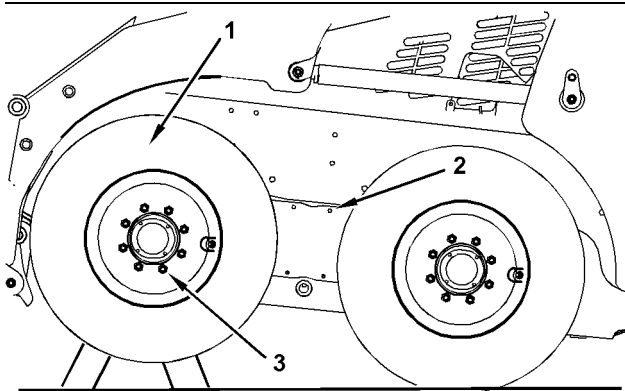

Illustration 206

g01025547

5. Remove the eight wheel nuts (3). Use an appropriate nylon lifting strap and a hoist in order to remove the tire and rim (1). The approximate weight of the standard tire and rim is 51 kg (113 lb).
6. Remove bolts and the cover (2) for the drive chain case.

**Note:** Remove the sealant from the cover and from the machine.

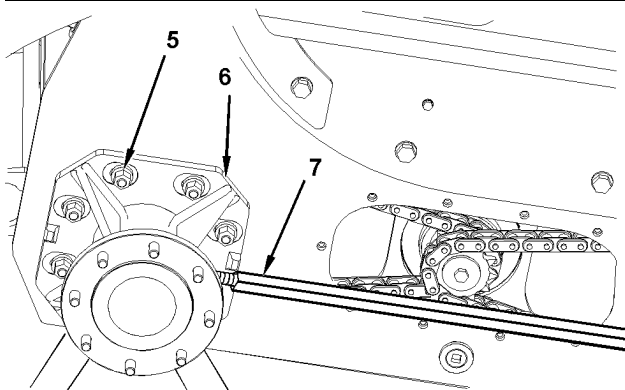

Illustration 207

g01025571

7. Loosen the eight bolts (5) for the axle housing. Place 159 - 3337 Chain Tension Adjuster (7) between the axle housings (6).

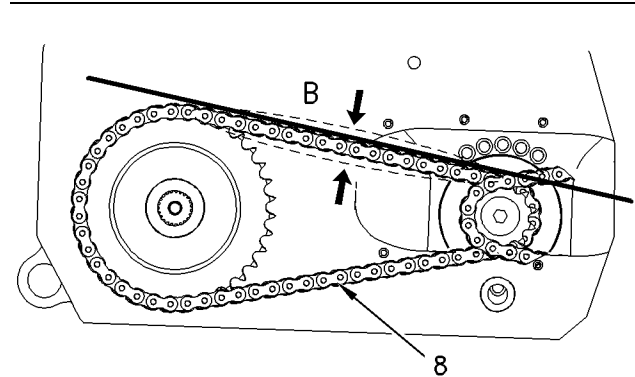

Illustration 208

g00867842

8. Rotate the axle in order to ensure that the chain (8) is taut below the sprockets. Place a straight edge across the top of the sprockets. Measure the total amount of movement in the chain (B). Set the chain tension so that there is a total of 15 mm (0.6 inch) movement in the chain. This is equal to 7.5 mm (0.3 inch) of movement above the straight edge and 7.5 mm (0.3 inch) of movement below the straight edge.

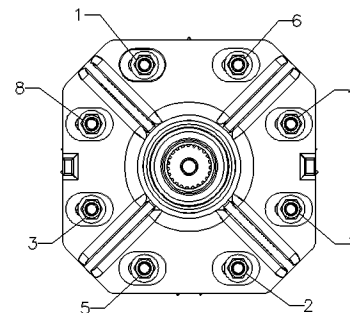

Illustration 209

g00554036

9. Tighten the bolts for the axle housing in the order that is shown above to  $160 \pm 15 \text{ N}\cdot\text{m}$  ( $118 \pm 11 \text{ lb ft}$ ). Turn the nuts an additional  $60 \pm 5^\circ$  in the same star pattern.
10. Remove the chain tension adjuster.
11. Install the bolts and the cover for the drive chain case.

**Note:** Use 8T - 9022 Silicone Gasket in order to seal the cover to the machine.

12. Use an appropriate nylon lifting strap and a hoist in order to position the tire and rim to the axle. The approximate weight of the tire and rim is 51 kg (113 lb). Refer to Operation and Maintenance Manual, "Wheel Nuts - Tighten" for the procedure to tighten the wheel nuts.
13. Lower the front of the machine to the ground. Repeat the procedure on the opposite side of the machine if it is necessary.
14. Repeat the adjustment procedure on the rear drive chains if it is necessary.

i03880059

## Engine Air Filter Primary Element - Clean/Replace

**SMCS Code:** 1054-510-PY; 1054-070-PY

### NOTICE

Never service the air cleaner when the engine is running, to avoid engine damage.

### NOTICE

Caterpillar recommends certified air filter cleaning services that are available at Caterpillar dealers. The Caterpillar cleaning process uses proven procedures to assure consistent quality and sufficient filter life.

Observe the following guidelines if you attempt to clean the filter element:

Do not tap or strike the filter element in order to remove dust.

Do not wash the filter element.

Use low pressure compressed air in order to remove the dust from the filter element. Air pressure must not exceed 207 kPa (30 psi). Direct the air flow up the pleats and down the pleats from the inside of the filter element. Take extreme care in order to avoid damage to the pleats.

Do not use air filters with damaged pleats, gaskets, or seals. Dirt entering the engine will cause damage to engine components.

Service the air filter elements when the alert indicator for air filter restriction lights. Refer to Operation and Maintenance Manual, "Alert Indicators".

The air filter housing is located on the left side of the engine compartment on machines that are equipped with the C2.2 engine. The air filter housing is located on the right side of the engine compartment on machines that are equipped with the C3.4 engine.

## Clean

**The primary filter element can be used up to three times if the element is properly cleaned and if the element is properly inspected.** When the primary filter element is cleaned, check for rips or tears in the filter material. The primary filter element should be replaced at least one time per year. This replacement should be performed regardless of the number of cleanings.

1. Open the engine access door.

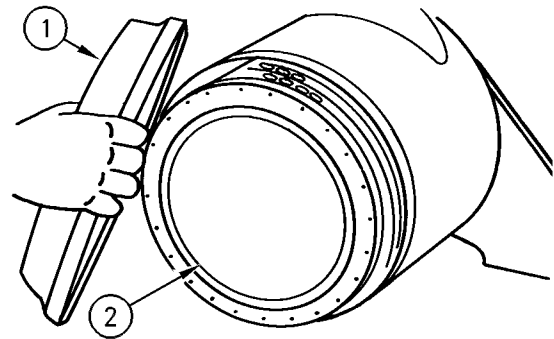

Illustration 210

g00101864

2. Unlatch the air cleaner housing cover (1). Rotate the cover counterclockwise and remove the cover.
3. Remove the primary filter element (2).
4. If it is appropriate, clean the primary filter element. Use air pressure to clean the primary filter elements. Pressurized air will not remove deposits of carbon and oil. Use filtered, dry air with a maximum pressure of 207 kPa (30 psi).

**Note:** When the primary filter elements are cleaned, always begin with the inside in order to force dirt particles toward the outside. Aim the hose so that the air flows inside the element along the length of the filter in order to help prevent damage to the paper pleats. Do not aim the stream of air directly at the primary filter element.

5. Inspect the cleaned, dry primary air filter element. Use a 60 watt blue light in a dark room or in a similar facility. Place the blue light in the primary air filter element. Rotate the primary air filter element. Inspect the primary air filter element for tears and/or holes. Inspect the primary air filter element for light that may show through the filter material. If it is necessary in order to confirm the result, compare the primary air filter element to a new primary air filter element that has the same part number.

**Note:** Do not use a primary air filter element that has any tears and/or holes in the filter material. Do not use a primary air filter element with damaged pleats, gaskets or seals. Discard damaged primary air filter elements.

6. Clean the inside of the air cleaner housing with a damp cloth. Do not use compressed air to clean the housing.
7. Install the primary filter element into the filter housing.
8. Install the cover for the filter housing.

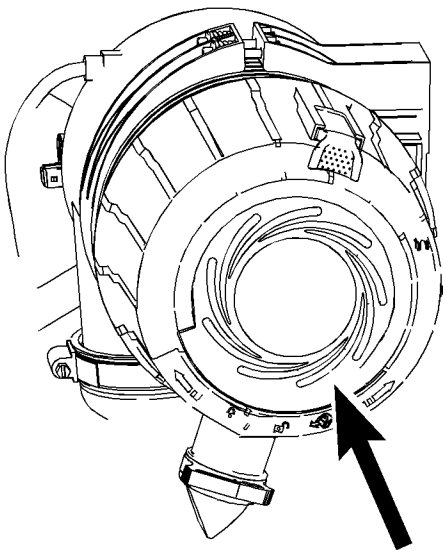

Illustration 211

g01433098

9. Rotate the cover clockwise and latch the cover.
10. Close the engine access door.
11. Start the engine. The alert indicator for air filter restriction should turn off. If the alert indicator continues to light, replace the secondary air filter. Refer to Operation and Maintenance Manual, "Engine Air Filter Secondary Element - Replace".

## Replace

The primary filter element should be replaced at least one time per year. **You can clean the primary filter up to three times.**

1. Open the engine access door.

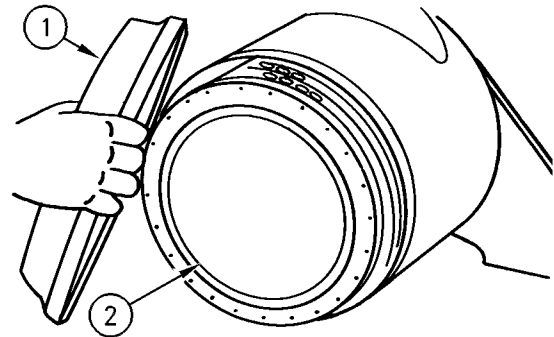

Illustration 212

g00101864

2. Unlatch the air cleaner housing cover (1). Rotate the cover counterclockwise and remove the cover.
3. Remove the primary filter element (2).
4. Clean the inside of the air cleaner housing with a damp cloth. Do not use compressed air to clean the housing.
5. Install a new primary filter element into the filter housing.
6. Install the cover for the filter housing.

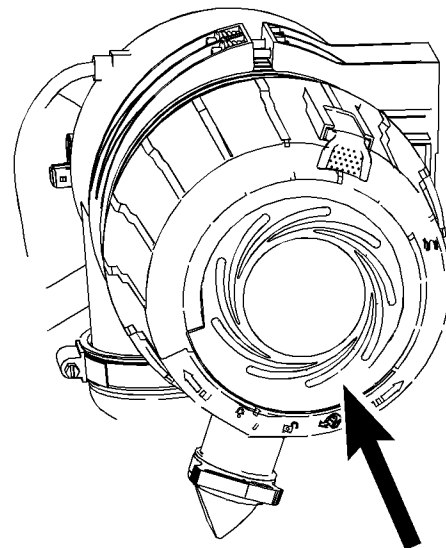

Illustration 213

g01433098

7. Rotate the cover clockwise and latch the cover.
8. Reset the air filter service indicator. Refer to Operation and Maintenance Manual, "Engine Air Filter Service Indicator - Inspect".
9. Close the engine access door.

Maintenance Section  
 Engine Air Filter Secondary Element - Replace

10. Start the engine. The alert indicator for air filter restriction should turn off. If the alert indicator continues to light, replace the secondary air filter. Refer to Operation and Maintenance Manual, "Engine Air Filter Secondary Element - Replace".

i02879321

## Engine Air Filter Secondary Element - Replace

SMCS Code: 1054-510-SE

### NOTICE

**Always replace the secondary filter element. Never attempt to reuse the secondary filter element by cleaning the element.**

When the primary filter element is cleaned for the third time, the secondary filter element should be replaced.

The secondary filter element should also be replaced if the restricted Air Filter indicator comes on after the installation of a clean primary filter element or if the exhaust smoke is still black.

The air filter housing is located on the left side of the engine compartment on machines that are equipped with the C2.2 engine. The air filter housing is located on the right side of the engine compartment on machines that are equipped with the C3.4 engine.

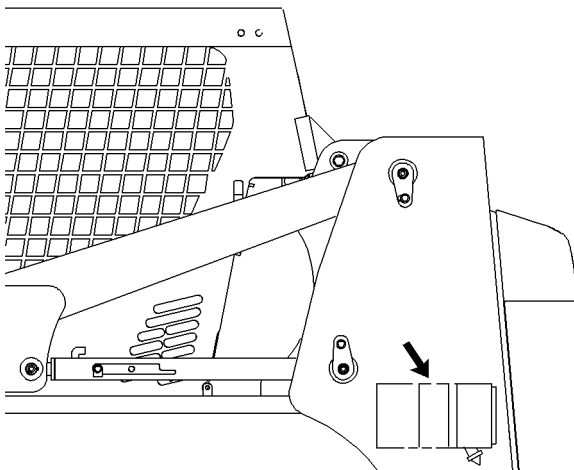

Illustration 214

g00891467

1. Open the engine access door.

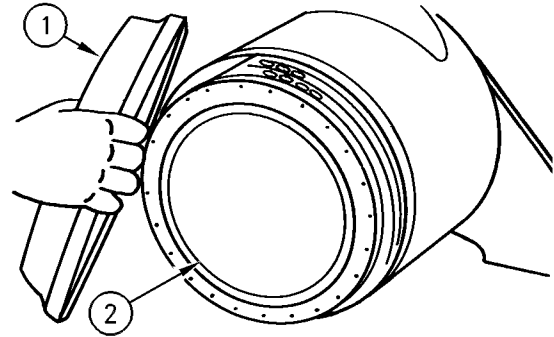

Illustration 215

g00101864

2. Unlatch the air cleaner housing cover (1). Rotate the cover counterclockwise and remove the cover.  
 3. Remove the primary filter element (2).

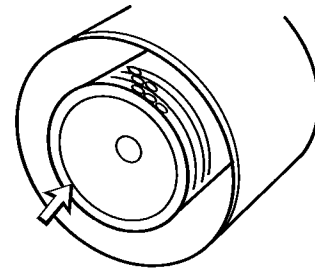

Illustration 216

g00038606

4. Clean the inside of the air cleaner housing with a damp cloth. Do not use compressed air to clean the housing.  
 5. Remove the secondary filter element.  
 6. Cover the air inlet opening.  
 7. Clean the inside of the air cleaner housing with a damp cloth, if necessary. Do not use compressed air to clean the housing.  
 8. Uncover the air inlet opening.  
 9. Install a new secondary element.  
 10. Install the primary element.  
 11. Install the cover for the filter housing.

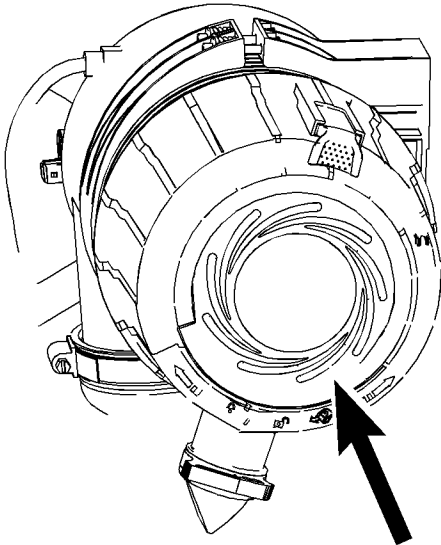

Illustration 217

g01433098

12. Rotate the cover clockwise and latch the cover.
13. Close the engine access door.

i03886451

## Engine Compartment - Inspect/Clean

**SMCS Code:** 1000-070-CPA; 1000-040-CPA

Inspect the engine compartment for dirt buildup or debris. Remove any dirt or debris from the engine compartment.

1. Open the engine access door. Refer to Operation and Maintenance Manual, "Access Doors and Covers".

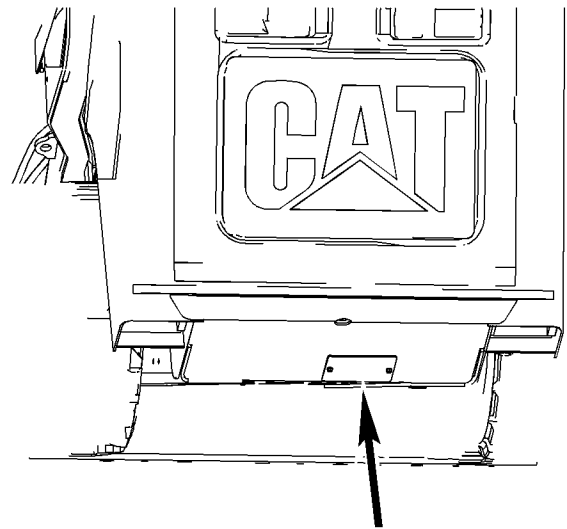

Illustration 218

g01264593

2. Remove any debris or dirt from the engine compartment. If equipped, remove the access panel in order to clean out the engine compartment.

**Note:** Use care when you clean the engine compartment. Damage to the machine may occur.

3. Close the engine access door.

## Air Conditioning Condenser

The air conditioning condenser is located at the back of the engine compartment. Cleaning the air conditioning condenser will maintain optimum performance of the air conditioning system.

Use low pressure water in order to clean the condenser.

i03880064

## Engine Crankcase Breather - Clean

**SMCS Code:** 1317-070

- S/N:** AS21-Up
- S/N:** HR21-Up
- S/N:** CD31-Up
- S/N:** KB31-Up
- S/N:** SNA1-Up
- S/N:** MWD1-Up

Maintenance Section  
 Engine Crankcase Breather - Clean

**S/N:** PWK1–Up

**S/N:** ESL1–Up

**S/N:** TSL1–Up

**S/N:** JXM1–Up

**S/N:** DSN1–Up

**S/N:** DXZ1–Up

**Note:** Ensure that the area around the vent hole on the breather cover is clean and that the vent hole is not restricted. Ensure that the components of the breather assembly are seated in the correct positions. Otherwise, engine damage could result.

1. Open the engine access door. Refer to Operation and Maintenance Manual, “Access Doors and Covers”.
2. Tilt the radiator upward. Refer to Operation and Maintenance Manual, “Radiator Tilting”.

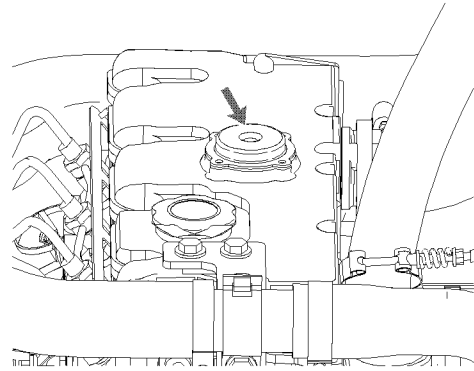

Illustration 219

g01018945

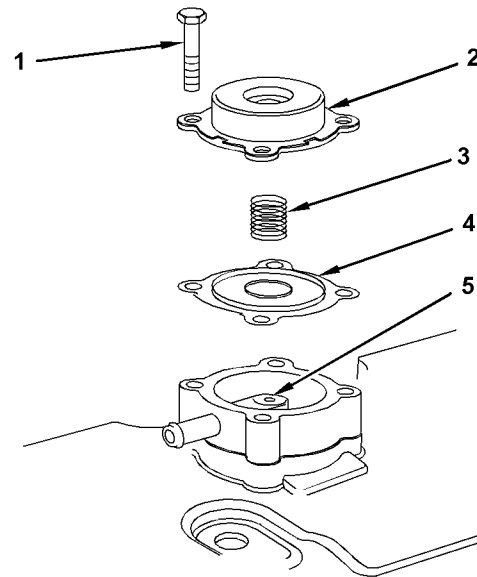

Illustration 220

g01044243

3. The breather is located on top of the valve cover. Remove the screws (1). Remove the breather cover (2).
4. Remove the diaphragm assembly (4). Remove the spring (3). The diaphragm assembly consists of the diaphragm and the locating ring.
5. Clean the cavity for the breather (5).
6. Remove the gauze that is located below the cavity for the breather.
7. Clean the following items with a clean diesel fuel:
  - Breather
  - Breather cover
  - Diaphragm assembly

- Location ring assembly
  - Spring
  - Gauze
8. Allow the parts to dry. Pressure air may be used to dry the parts.
  9. Install the gauze and install the components of the breather. Install the breather cover.
  10. Tilt the radiator downward.
  11. Close the engine access door.

i03880105

## Engine Oil Level - Check

**SMCS Code:** 1348-535-FLV

### NOTICE

Do not overfill the crankcase. Engine damage can result.

1. Stop the engine and allow the oil to drain back into the oil pan.

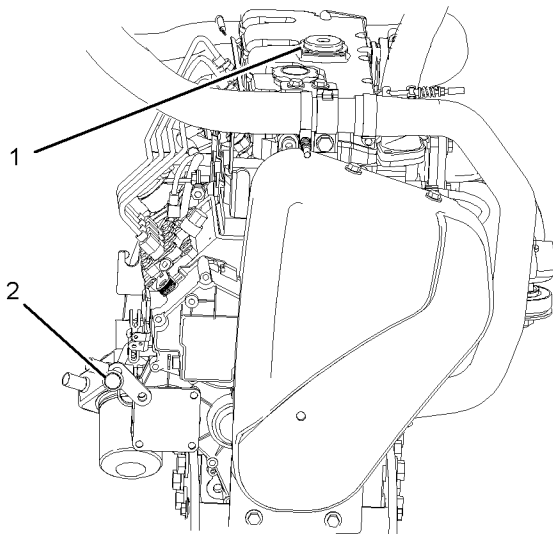

Illustration 221

g02126142

C2.2

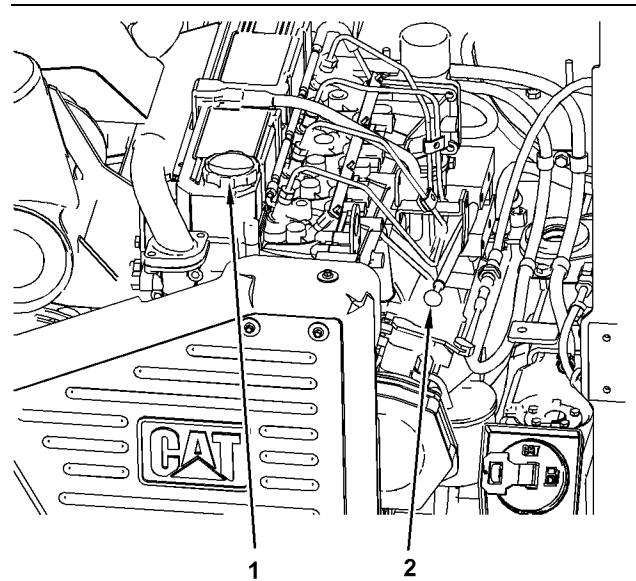

Illustration 222

g01209758

### C3.4

- (1) Oil Filler Cap
- (2) Oil Level Gauge

2. Open the engine access door. Refer to Operation and Maintenance Manual, "Access Doors and Covers".

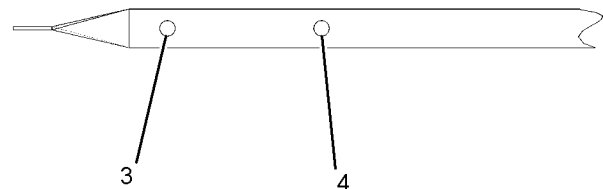

Illustration 223

g02126152

- (3) Add
- (4) Full mark

3. Maintain the level of the oil between the "ADD" (3) mark and the "FULL" (4) mark on the oil level gauge (2).
4. If oil is necessary, tilt the radiator upward. Refer to Operation and Maintenance Manual, "Radiator Tilting".
5. Remove the oil filler cap (1) and add oil.
6. Clean the oil filler cap and install the oil filler cap.

7. Tilt the radiator downward.
8. Close the engine access door.

i05354546

## Engine Oil Sample - Obtain

**SMCS Code:** 1348-554-SM; 7542-008

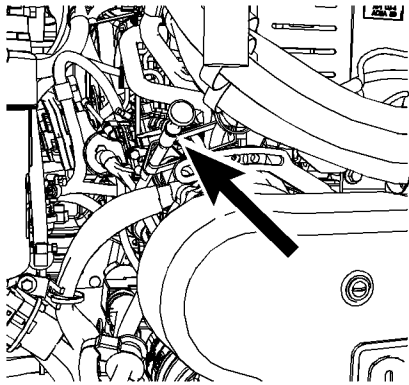

Illustration 224

g03392125

Obtain the oil sample of the engine oil through the opening for the dipstick.

**Reference:** For more information, refer to Special Publication, SEBU6250, "Caterpillar Machine Fluids Recommendations" "S·O·S Oil Analysis" and Special Publication, PEHP6001, "How To Take A Good Oil Sample".

i03880121

## Engine Oil and Filter - Change

**SMCS Code:** 1308-510; 1348-044

**S/N:** AS21–Up  
**S/N:** HR21–Up  
**S/N:** CD31–Up  
**S/N:** KB31–Up  
**S/N:** SNA1–Up  
**S/N:** MWD1–Up  
**S/N:** PWK1–Up  
**S/N:** ESL1–Up  
**S/N:** TSL1–Up  
**S/N:** JXM1–Up  
**S/N:** DSN1–Up  
**S/N:** DXZ1–Up

### NOTICE

Care must be taken to ensure that fluids are contained during performance of inspection, maintenance, testing, adjusting and repair of the product. Be prepared to collect the fluid with suitable containers before opening any compartment or disassembling any component containing fluids.

Refer to Special Publication, NENG2500, "Caterpillar Dealer Service Tool Catalog" for tools and supplies suitable to collect and contain fluids on Caterpillar products.

Dispose of all fluids according to local regulations and mandates.

The normal oil change interval for the machine is Every 500 Service Hours or every year when the following conditions are met:

- Use an engine oil in the Operation and Maintenance Manual, "Lubricant Viscosities".
- Caterpillar filters are used.
- The altitude does not exceed 2300 m (7545 ft).
- Sulfur content in the fuel is between 0.05% and 0.50%.

An oil change interval of Every 250 Service Hours or every six months is required when the following conditions occur:

- Use an engine oil in the Operation and Maintenance Manual, "Lubricant Viscosities".
- The altitude exceeds 2300 m (7545 ft).
- Sulfur content in the fuel is between 0.50% and 1.00%.

An oil change interval of Every 125 Service Hours is required when the following condition occurs:

- Sulfur content in the fuel is above 1.00%.

Refer to the results of the S·O·S oil analysis in order to determine if the oil change interval should be decreased. Consult your Caterpillar Dealer for detailed information regarding the optimum oil change interval.

1. Open the engine access door. Refer to Operation and Maintenance Manual, "Access Doors and Covers".
2. Tilt the radiator upward. Refer to Operation and Maintenance Manual, "Radiator Tilting".

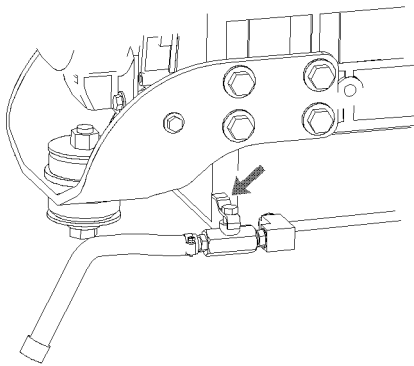

Illustration 225

g01022394

**Note:** The crankcase drain is located on the right side of the oil pan.

3. Pull the drain hose for the crankcase through the opening in the rear of the machine and remove the plug in the end of the drain hose. Open the crankcase drain valve and drain the oil into a suitable container. Close the crankcase drain valve. Install the plug in the drain hose.

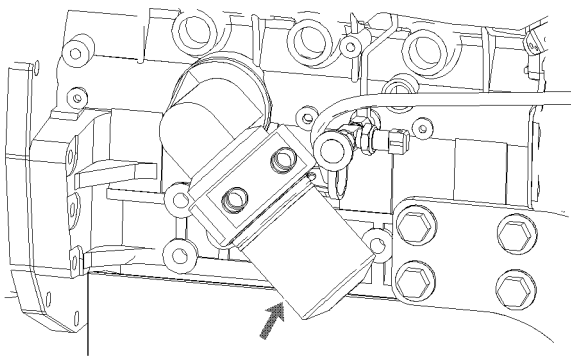

Illustration 226

g01022354

4. Remove the filter element with a 187 - 2718 Filter Wrench. Refer to Operation and Maintenance Manual, "Oil Filter - Inspect" in order to inspect the used filter for debris.
5. Apply a thin film of clean engine oil to the sealing surface of the new filter element.
6. Install a new engine oil filter hand tight until the seal of the engine oil filter contacts the base. Note the position of the index marks on the filter in relation to a fixed point on the filter base.

**Note:** There are rotation index marks on the engine oil filter that are spaced 90 degrees or 1/4 of a turn away from each other. When you tighten the engine oil filter, use the rotation index marks as a guide.

7. Tighten the filter according to the instructions that are printed on the filter. Use the index marks as a guide.

**Note:** You may need to use a Caterpillar strap wrench, or another suitable tool, in order to turn the filter to the amount that is required for final installation. Make sure that the installation tool does not damage the filter.

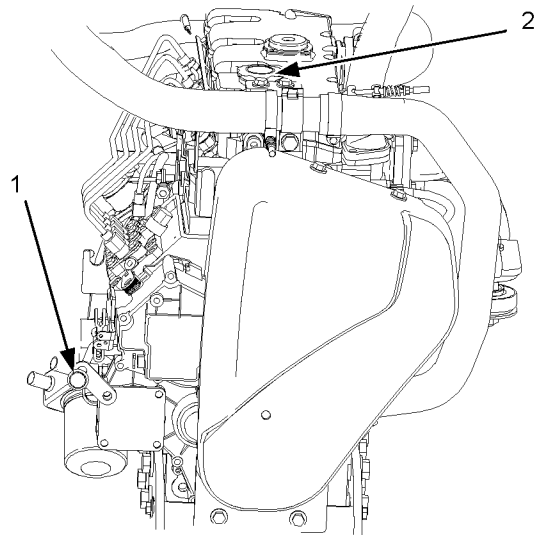

Illustration 227

g01018561

8. Remove the oil filler cap(2). Fill the crankcase with new oil. See Operation and Maintenance Manual, "Lubricant Viscosities" and Operation and Maintenance Manual, "Refill Capacities". Clean the oil filler plug and install the oil filler plug.
9. Start the engine and allow the oil to warm. Check for leaks.

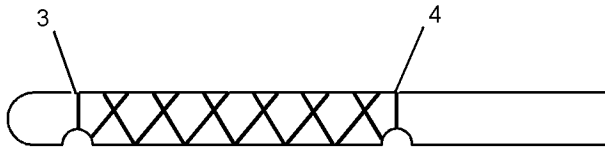

Illustration 228

g02126167

10. Stop the engine and allow the oil to drain back into the oil pan. Fill the crankcase to the "FULL" mark (4) on the oil level gauge (1). **Do not exceed the "FULL" mark on the dipstick.** Add oil or drain oil if it is necessary.
11. Tilt the radiator downward.
12. Close the engine access door.

i03900344

## Engine Oil and Filter - Change

**SMCS Code:** 1308-510; 1348-044

**S/N:** HR21–Up  
**S/N:** A9H1–Up  
**S/N:** B7H1–Up  
**S/N:** PWK1–Up  
**S/N:** TNK1–Up  
**S/N:** SRS1–Up  
**S/N:** DXZ1–Up  
**S/N:** YYZ1–Up

### NOTICE

Care must be taken to ensure that fluids are contained during performance of inspection, maintenance, testing, adjusting and repair of the product. Be prepared to collect the fluid with suitable containers before opening any compartment or disassembling any component containing fluids.

Refer to Special Publication, NENG2500, "Caterpillar Dealer Service Tool Catalog" for tools and supplies suitable to collect and contain fluids on Caterpillar products.

Dispose of all fluids according to local regulations and mandates.

The normal oil change interval for the machine is Every 500 Service Hours or every year when the following conditions are met:

- Use an engine oil in the Operation and Maintenance Manual, "Lubricant Viscosities".
- Caterpillar filters are used.
- The altitude does not exceed 2300 m (7545 ft).
- Sulfur content in the fuel is between 0.05% and 0.50%.

An oil change interval of Every 250 Service Hours or every six months is required when the following conditions occur:

- Use an engine oil in the Operation and Maintenance Manual, "Lubricant Viscosities".
- The altitude exceeds 2300 m (7545 ft).
- Sulfur content in the fuel is between 0.50% and 1.00%.

An oil change interval of Every 125 Service Hours is required when the following condition occurs:

- Sulfur content in the fuel is above 1.00%.

Refer to the results of the S·O·S oil analysis in order to determine if the oil change interval should be decreased. Consult your Caterpillar Dealer for detailed information regarding the optimum oil change interval.

1. Open the engine access door. Refer to Operation and Maintenance Manual, "Access Doors and Covers".
2. Tilt the radiator upward. Refer to Operation and Maintenance Manual, "Radiator Tilting".

**Note:** The crankcase drain is located on the right side of the oil pan.

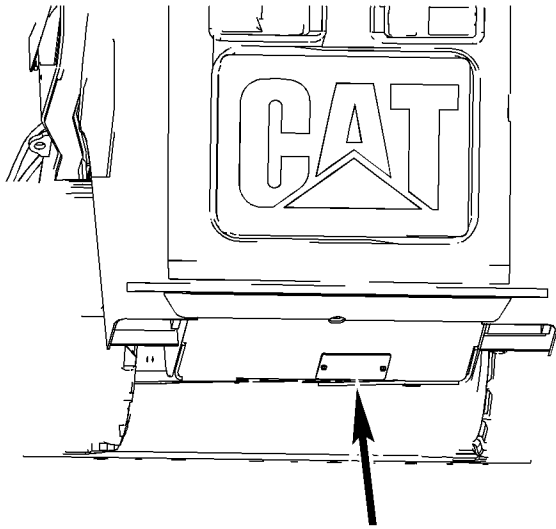

Illustration 229

g01264593

3. Remove the access panel that is located below the drain plug. Remove the drain plug and allow the oil to drain into a suitable container. Install the drain plug.

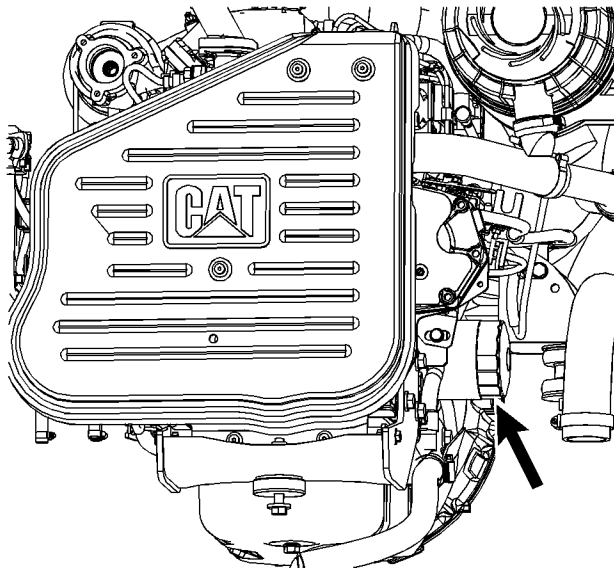

Illustration 230

g02143271

4. Remove the filter element with a 187-2718 Filter Wrench. Refer to Operation and Maintenance Manual, "Oil Filter - Inspect" in order to inspect the used filter for debris.
5. Apply a thin film of clean engine oil to the sealing surface of the new filter element.

6. Install a new engine oil filter hand tight until the seal of the engine oil filter contacts the base. Note the position of the index marks on the filter in relation to a fixed point on the filter base.

**Note:** There are rotation index marks on the engine oil filter that are spaced 90 degrees or 1/4 of a turn away from each other. When you tighten the engine oil filter, use the rotation index marks as a guide.

7. Tighten the filter according to the instructions that are printed on the filter. Use the index marks as a guide. For non-Caterpillar filters, use the instructions that are provided with the filter.

**Note:** You may need to use a Caterpillar strap wrench, or another suitable tool, in order to turn the filter to the amount that is required for final installation. Make sure that the installation tool does not damage the filter.

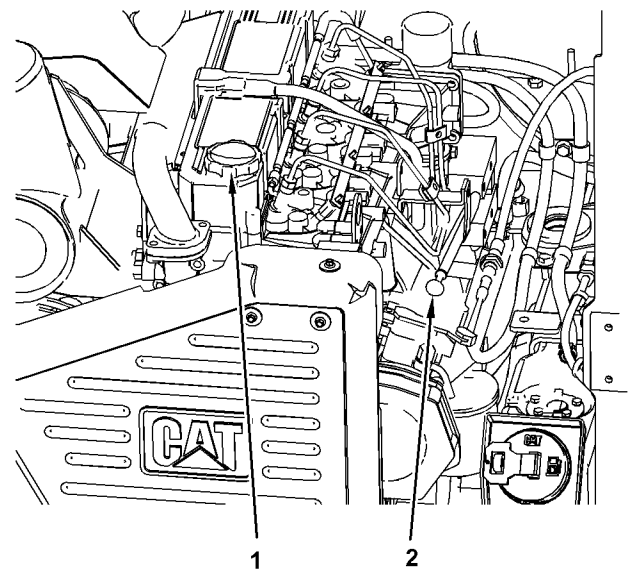

Illustration 231

g01209758

- (1) Oil Filler Cap  
(2) Dipstick

8. Remove the oil filler cap (1). Fill the crankcase with new oil. Refer to Operation and Maintenance Manual, "Lubricant Viscosities" and Operation and Maintenance Manual, "Refill Capacities" for information about the oil. Clean the oil filler plug and install the oil filler plug.
9. Start the engine and allow the oil to warm. Check for leaks.

Maintenance Section  
Engine Valve Lash - Check

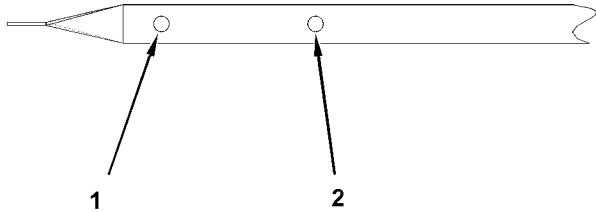

Illustration 232

g01277108

- (1) Oil level add mark  
(2) Full mark

**10.** Stop the engine and allow the oil to drain back into the oil pan. Fill the crankcase to the "FULL" mark (2) on the dipstick. **Do not exceed the "FULL" mark on the dipstick.** Add oil or drain oil if it is necessary.

**11.** Tilt the radiator downward.

**12.** Close the engine access door.

**13.** Install the access panel.

i06849849

## Engine Valve Lash - Check

**SMCS Code:** 1105-025

Refer to the Service Manual for the complete adjustment procedure for the engine valve lash.

A qualified mechanic should adjust the engine valve lash and the fuel injector timing because special tools and training are required.

See your Cat dealer for this service.

i03880157

## Equipment Lowering Control Valve - Check

**SMCS Code:** 5147-MA

### WARNING

Personal injury or death can result from a work tool falling.

Keep personnel away from the front of the machine when lowering the work tool.

Before lowering any equipment, clear the area around the equipment of all personnel.

1. Lower arms to the fully lowered position. Turn the keyswitch to the OFF position.

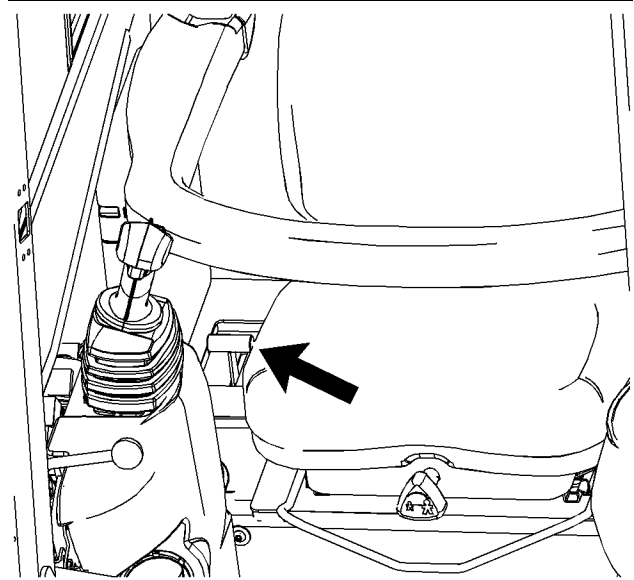

Illustration 233

g02141938

2. Push reward on the handle in order to fully actuate the valve.

3. Pull forward on the handle in order to return the handle to the original position. Ensure that the handle is fully seated.

i07328960

## Final Drive Oil - Change

**SMCS Code:** 4011-044-OC; 4050; 4050-044-FLV; 4050-535-FLV; 4050-044; 4050-044-OC; 4070-044; 7527

**S/N:** HR21-Up

**S/N:** KB31-Up

**S/N:** B7H1-Up

**S/N:** PWK1-Up

**S/N:** ESL1-Up

**S/N:** TSL1-Up

**S/N:** DXZ1-Up

**S/N:** YYZ1-Up

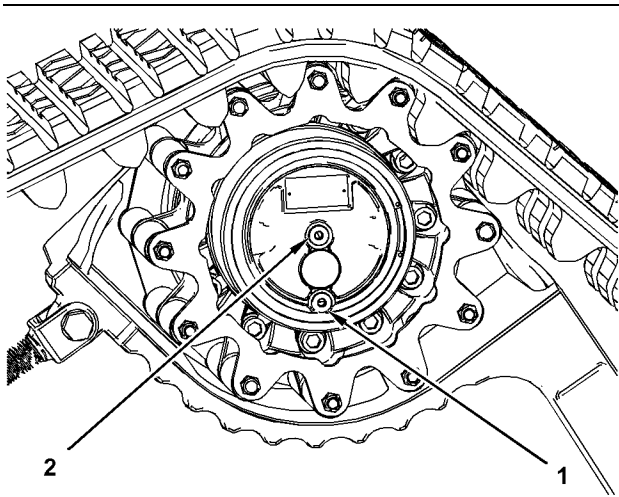

Illustration 234

g01291697

Multi-Terrain Loader

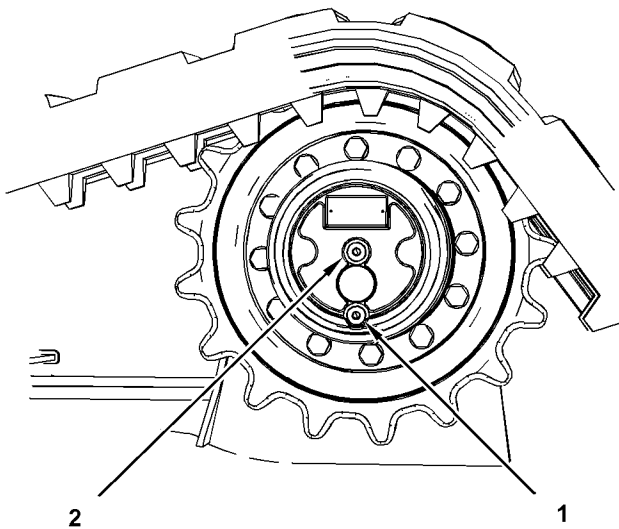

Illustration 235

g01451295

Compact Track Loader

- (1) Oil fill/drain plug  
(2) Oil check plug

## Final Drive Oil - Change Procedure

1. Position one final drive so that the oil fill/drain plug (1) is at the bottom.

**Note:** Refer to Operation and Maintenance Manual, "General Hazard Information" for information on containing fluid spillage.

2. Use an 8 mm (5/16 inch) allen wrench. Remove the oil plugs (1) and (2). Allow the oil to drain into a suitable container.
3. Check the drained oil for large metal chips or a significant number of metal particles.

**Note:** Some small amount of break-in debris is normal and should not cause alarm.

**Note:** Dispose of drained fluids according to local regulations.

4. Clean the plugs and inspect the plugs. Replace a worn plug or a damaged plug.
5. Position the final drive so that the oil fill/drain plug (1) is at the top.
6. Add oil through the opening of the oil fill/drain plug (1) that is now at the top.
7. Fill the final drive to the bottom of the opening for the oil check plug (2). Refer to Operation and Maintenance Manual, "Lubricant Viscosities" and Operation and Maintenance Manual, "Capacities (Refill)".
8. Install the two oil plugs. Tighten the oil plugs to a torque of  $27 \pm 1 \text{ N}\cdot\text{m}$  ( $20 \pm 0.7 \text{ lb ft}$ ).
9. Perform Step 1 to Step 8 on the other final drive.
10. Completely remove any oil that has spilled.
11. Start the engine and allow the final drives to operate through several cycles.
12. Stop the engine.
13. Check the oil level.
14. Maintain the oil level to the bottom of the opening for the fill/drain plug (2).

i03880192

## Final Drive Oil Level - Check

**SMCS Code:** 4011-535-FLV; 4050; 4050-535-FLV; 4070-535-FLV; 7524; 7527

**S/N:** HR21-Up

**S/N:** KB31-Up

**S/N:** B7H1-Up

**S/N:** PWK1-Up

**S/N:** ESL1-Up

**S/N:** TSL1-Up

**S/N:** DXZ1-Up

**S/N:** YYZ1-Up

Maintenance Section  
Fuel Injection Timing - Check

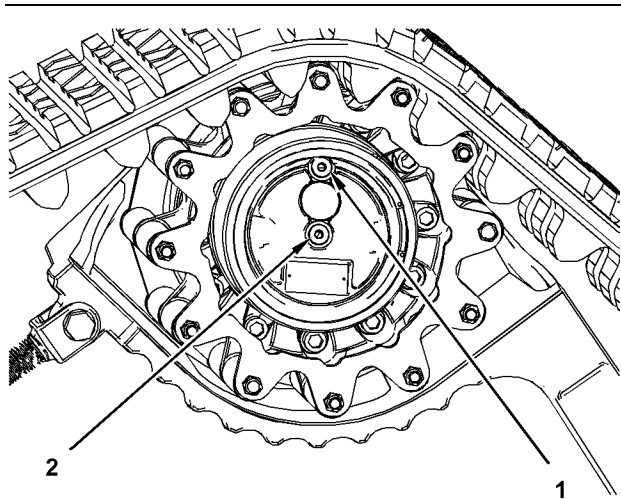

Illustration 236

g01457026

Multi Terrain Loader

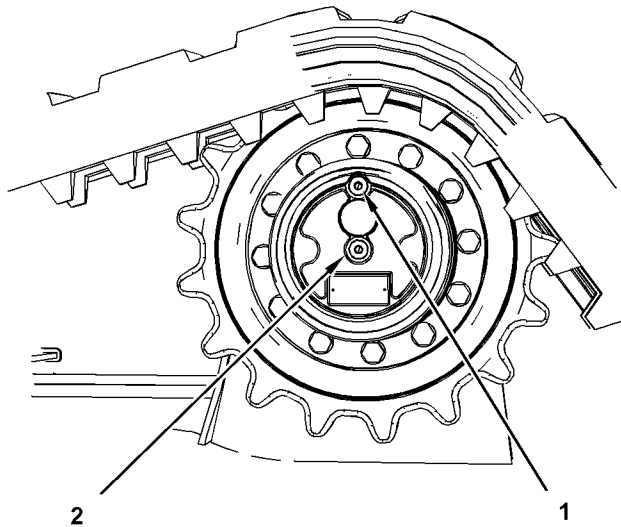

Illustration 237

g01457009

Compact Track Loader

- (1) Oil fill/drain plug  
(2) Oil check plug

1. Position one final drive so that the oil fill/drain plug (1) is at the top.

**Note:** Refer to Operation and Maintenance Manual, "General Hazard Information" for information on Containing Fluid Spillage.

2. Use an 8 mm (5/16 inch) allen wrench. Remove the oil check plug (2).

3. Check the oil level. The oil should be near the bottom of the opening for the oil check plug (2).
4. Add oil through the opening for the oil fill/drain plug (1), if necessary.

**Note:** Overfilling the final drive will cause the seals on the travel motor to allow hydraulic oil or water to enter the final drive. This may contaminate the final drive.

5. Clean the oil plugs.
6. Install the oil plugs. Tighten the oil plugs to a torque of  $27 \pm 1$  N·m ( $20 \pm 0.7$  lb ft).
7. Repeat the procedure for the other final drive.

i00916186

## Fuel Injection Timing - Check

**SMCS Code:** 1251-531

**Note:** The correct fuel timing specification is found on the Engine Information Plate. Fuel timing specifications may vary for different engine applications and/or for different power ratings.

A qualified mechanic should adjust the fuel injection timing because special tools and training are required.

Refer to the Service Manual for the complete adjustment procedure for the fuel injection timing. Refer to your Caterpillar dealer for the complete adjustment procedure for the fuel injection timing.

i02868096

## Fuel System Filter (In-Line) - Replace

**SMCS Code:** 1261-510

- S/N: AS21-Up  
S/N: HR21-Up  
S/N: CD31-Up  
S/N: KB31-Up  
S/N: SNA1-Up  
S/N: MWD1-Up  
S/N: PWK1-Up  
S/N: ESL1-Up  
S/N: TSL1-Up  
S/N: JXM1-Up  
S/N: DSN1-Up

S/N: DXZ1–Up

**NOTICE**

Care must be taken to ensure that fluids are contained during performance of inspection, maintenance, testing, adjusting and repair of the product. Be prepared to collect the fluid with suitable containers before opening any compartment or disassembling any component containing fluids.

Refer to Special Publication, NENG2500, "Caterpillar Dealer Service Tool Catalog" for tools and supplies suitable to collect and contain fluids on Caterpillar products.

Dispose of all fluids according to local regulations and mandates.

**Note:** Replace the fuel filter before the scheduled interval if any of the following occur:

- The filter screen is more than half obstructed.
- Engine performance is poor.

1. Open the engine access door. Refer to Operation and Maintenance Manual, "Access Doors and Covers".

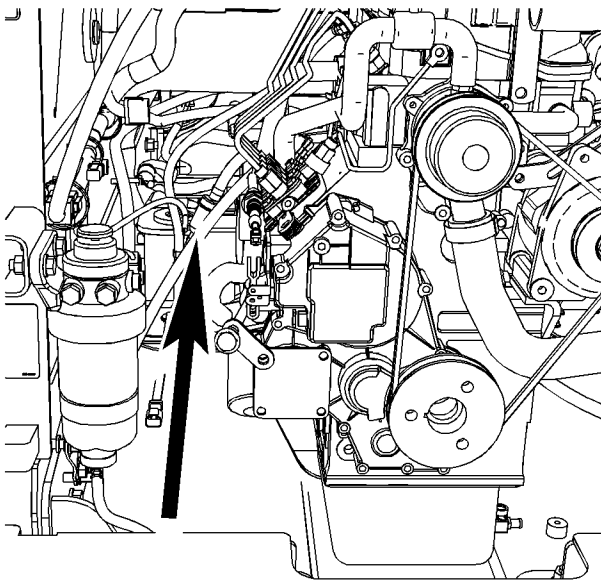

Illustration 238

g01428665

2. Loosen hose clamps.
3. Remove the fuel filter and discard the fuel filter.
4. Replace the fuel filter. Ensure that the arrow on the filter points upward.
5. Tighten hose clamps.
6. Start the engine.

7. Check for leaks.

8. Close the engine access door.

i03880387

## Fuel System Primary Filter (Water Separator) - Drain

SMCS Code: 1263-543

**NOTICE**

Care must be taken to ensure that fluids are contained during performance of inspection, maintenance, testing, adjusting and repair of the product. Be prepared to collect the fluid with suitable containers before opening any compartment or disassembling any component containing fluids.

Refer to Special Publication, NENG2500, "Caterpillar Dealer Service Tool Catalog" for tools and supplies suitable to collect and contain fluids on Caterpillar products.

Dispose of all fluids according to local regulations and mandates.

The fuel system water separator is located in the left side of the engine compartment.

1. Open the engine access door. Refer to Operation and Maintenance Manual, "Access Doors and Covers".

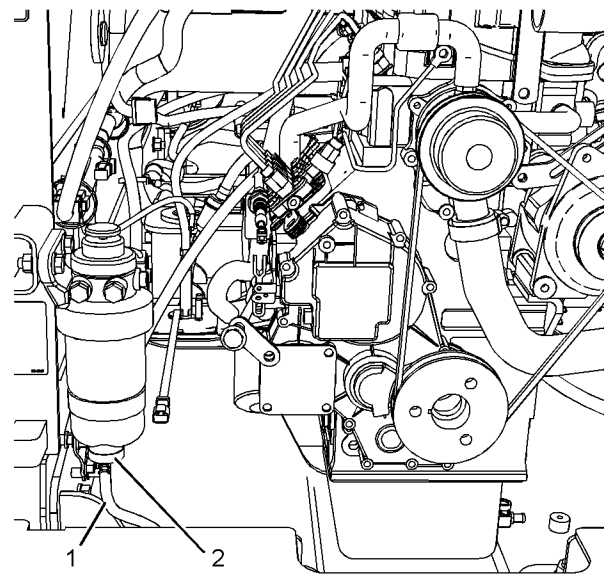

Illustration 239

g02126392

C2.2

i03880390

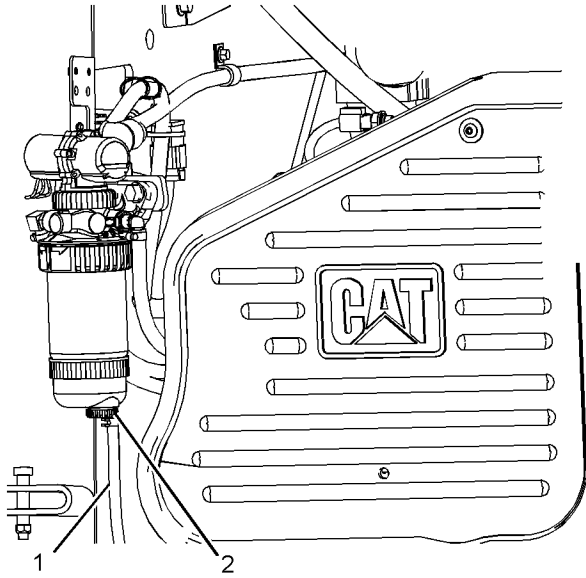

Illustration 240

g02126394

## C3.4

The Fuel Filter/Water Separator is located on the left side of the engine compartment.

2. Insert drain hose (1) into a suitable container. Loosen drain valve (2) on the bottom of the water separator.
3. Tighten drain valve (2) by hand. Do not tighten the drain valve with a tool. Damage to the valve or to the seals may occur.
4. Close the engine access door.
5. Dispose of the water and sediment according to local regulations.

## Fuel System Primary Filter (Water Separator) Element - Replace

SMCS Code: 1260-510-FQ; 1263-510-FQ

### NOTICE

Care must be taken to ensure that fluids are contained during performance of inspection, maintenance, testing, adjusting and repair of the product. Be prepared to collect the fluid with suitable containers before opening any compartment or disassembling any component containing fluids.

Refer to Special Publication, NENG2500, "Caterpillar Dealer Service Tool Catalog" for tools and supplies suitable to collect and contain fluids on Caterpillar products.

Dispose of all fluids according to local regulations and mandates.

**Note:** This unit has a dual purpose. The element serves as a water separator and a fuel filter.

1. Open the engine access door. Refer to Operation and Maintenance Manual, "Access Doors and Covers".

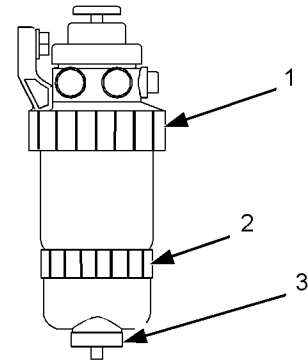

Illustration 241

g01017292

## C2.2

i03880392

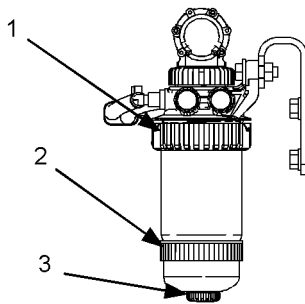

Illustration 242

g01017293

**C3.4**

2. Open the drain on the fuel filter/water separator (3). Allow the water and fuel to drain into a suitable container.
3. Close the drain valve by hand. Do not tighten the drain valve with a tool. Damage to the valve or to the seals may occur.
4. Support the fuel filter/water separator and rotate the locking ring (1) counterclockwise. Remove the fuel filter/water separator.
5. Rotate the locking ring (2) counterclockwise. Remove the bowl assembly.
6. Clean the mounting base for the fuel filter/water separator.
7. Clean the bowl assembly for the fuel/water separator.
8. Install the bowl assembly onto the new fuel/water separator and rotate the locking ring clockwise.
9. Install the new fuel filter/water separator onto the mounting base. Rotate the locking ring clockwise in order to fasten the fuel filter/water separator to the mounting base.
10. Prime the fuel system in order to fill the fuel filter/water separator with fuel. Refer to Operation and Maintenance Manual, "Fuel System Priming Pump - Operate".
11. Close the engine access door.

## Fuel System Priming Pump - Operate

SMCS Code: 1258-548

### C2.2 Engine

The fuel priming pump is located on top of the fuel filter/water separator.

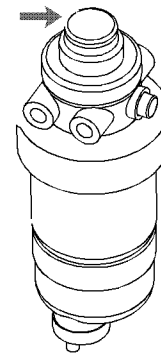

Illustration 243

g01019689

1. Open the engine access door. Refer to Operation and Maintenance Manual, "Access Doors and Covers".
2. Push down on the top of the fuel priming pump plunger and release the fuel priming pump plunger in order to operate the fuel priming pump. Operate the fuel priming pump plunger in order to fill the new filter element with fuel. Continue to pump until increased resistance is felt. This resistance will indicate that the filter element is full of fuel.
3. Attempt to start the engine. If the engine starts and the engine runs rough or the engine misfires, operate the engine at low idle until the engine runs smoothly. If the engine fails to start or if the engine continues to misfire or smoke repeat the priming procedure.
4. Close the engine access door.

### C3.4 Engine

Machines that are equipped with the C3.4 engine are equipped with a fuel transfer pump that is electric.

1. Momentarily turn the engine start switch to the START position and then return the engine start switch to the ON position.

**Note:** Do not start the engine. This operation only starts the fuel pump.

2. Leave the engine start switch in the ON position for thirty seconds.
3. Attempt to start the engine. If the engine starts and the engine runs rough or the engine misfires, operate the engine at low idle until the engine runs smoothly. If the engine fails to start or if the engine continues to misfire or smoke, repeat the priming procedure.

i01819309

## Fuel Tank Cap - Clean

**SMCS Code:** 1273-070-Z2

1. Remove the fuel cap.

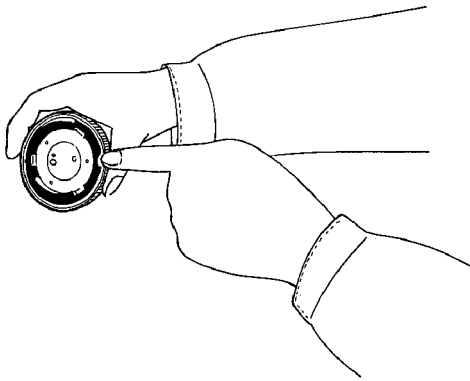

Illustration 244

g00104238

2. Inspect the cap. Replace the cap if the cap is damaged.
3. Wash the fuel cap in a clean, nonflammable solvent and dry the fuel cap.
4. Put a light coating of fuel on the cap gasket.
5. Install the fuel cap.

## Fuel Tank Water and Sediment - Drain

**SMCS Code:** 1273-543-M&S

i01971189

### NOTICE

Care must be taken to ensure that fluids are contained during performance of inspection, maintenance, testing, adjusting and repair of the product. Be prepared to collect the fluid with suitable containers before opening any compartment or disassembling any component containing fluids.

Refer to Special Publication, NENG2500, "Caterpillar Dealer Service Tool Catalog" for tools and supplies suitable to collect and contain fluids on Caterpillar products.

Dispose of all fluids according to local regulations and mandates.

**Note:** Drain the water and the sediment from the fuel tank when the tank is almost empty.

1. Slowly remove the fuel tank cap in order to relieve the tank pressure.

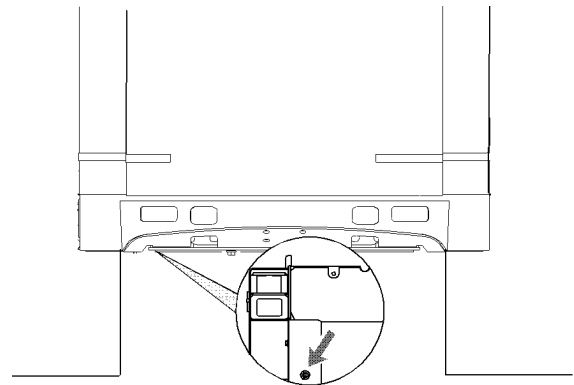

Illustration 245

g01023153

2. The fuel tank drain plug is located underneath the machine at the left rear corner. Loosen the plug.
3. Allow the water and the sediment to drain into a suitable container.
4. Install the fuel tank drain plug.

**Note:** Apply 5P - 3413 Pipe Sealant to the threads on the drain plug.

5. Install the fuel tank cap.

i03898484

## Fuses - Replace

SMCS Code: 1417-510; 1417; 7528

### Fuses

**Fuses** – Fuses protect the electrical system from damage that is caused by overloaded circuits. Replace the fuse if the element separates. If the element of a new fuse separates, check the circuit. Repair the circuit, if necessary.

**NOTICE**

Replace the fuses with the same type and size only. Otherwise, electrical damage can result.

If it is necessary to replace fuses frequently, an electrical problem may exist. Contact your Caterpillar dealer

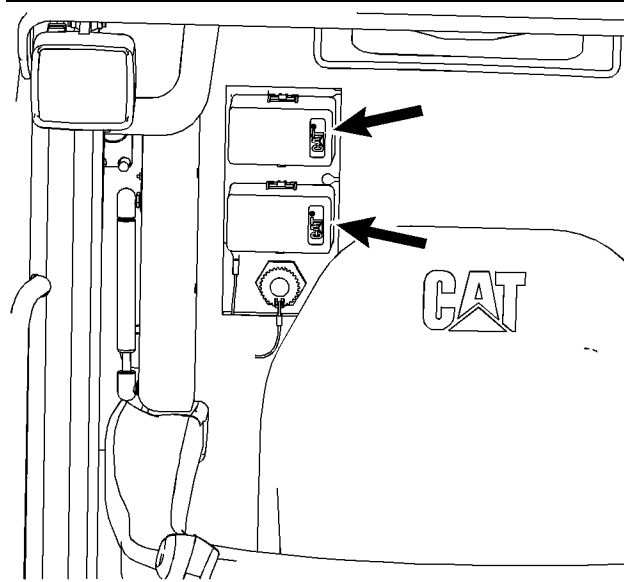

Illustration 246

g02142168

The fuse panel is located behind the seat on the right side.

Remove the cover in order to access the fuse panel.

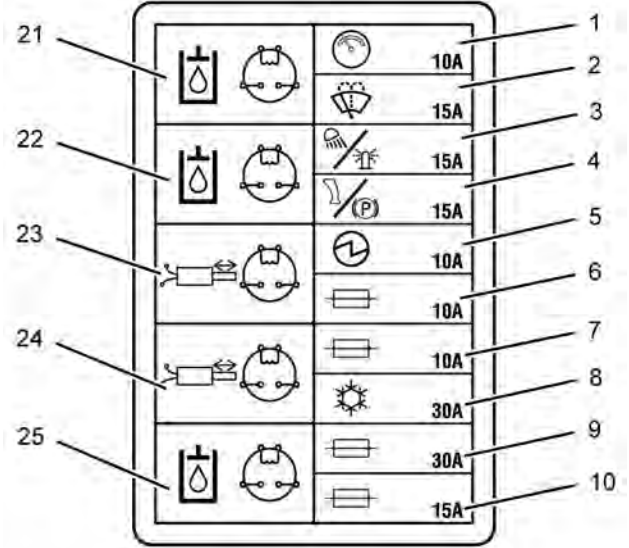

Illustration 247

g02142844

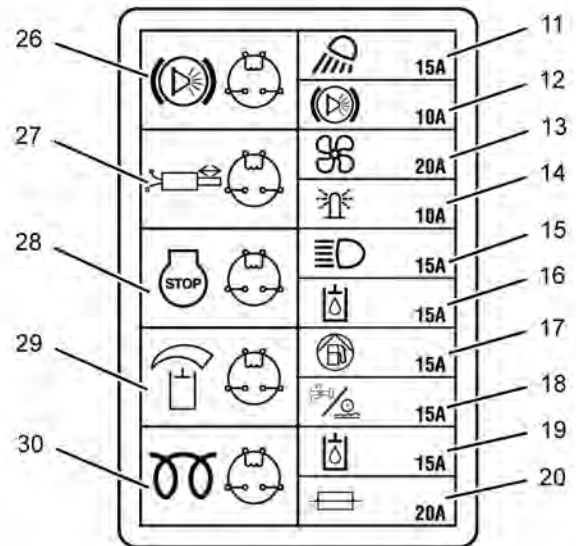

Illustration 248

g02142845

The following is a list of the fuses in the panel:



















**1 – Gauge**











**2 – Wiper**



**3 – Rear Work Lights and Beacon**

-  **4 – Right Joystick and Parking Brake Solenoid**
-  **5 – 12 volt power socket**
-  **6 – Spare**
-  **7 – Spare**
-  **8 – Air Conditioner Condenser Fans**
-  **9 – Spare**
-  **10 – Spare**
-  **11 – Front Work Lights**
-  **12 – Stop Lamp and Back-Up Alarm**
-  **13 – HVAC Blower Fan**
-  **14 – Beacon**
-  **15 – Headlights**
-  **16 – Work Tool Auxiliary Electrical Control (Pin H)**
-  **17 – Fuel Pump**
-  **18 – Hydraulic Quick Coupler and Self Level**
-  **19 – Work Tool Auxiliary Electrical Control Left Hand C1/C2 and right Hand Trigger (Pins B,C, & D)**
-  **20 – Spare**

**Solenoids**

-  **21 – Auxiliary Electrical Control “AUX6 (C1)”**
-  **22 – Auxiliary Electrical Control “AUX5 (C2)”**
-  **23 – Secondary Auxiliary Electrical Control “(C+)”**
-  **24 – Secondary Auxiliary Electrical Control “(C-)”**
-  **25 – Auxiliary Electrical Control “AUX7”**
-  **26 – Stop Lamp**
-  **27 – Secondary Auxiliary Electrical Control**
-  **28 – Fuel Shutoff**
-  **29 – Hydraulic Flow Control**

**30 – Glow Plugs****Main Fuse**

Illustration 249

g02142334

The main fuse (31) is located on the left side of the machine in the rear next to the engine. This is a 105 amp fuse. You must disconnect the negative battery cable before you replace this fuse.

**Fuse panel behind cab**

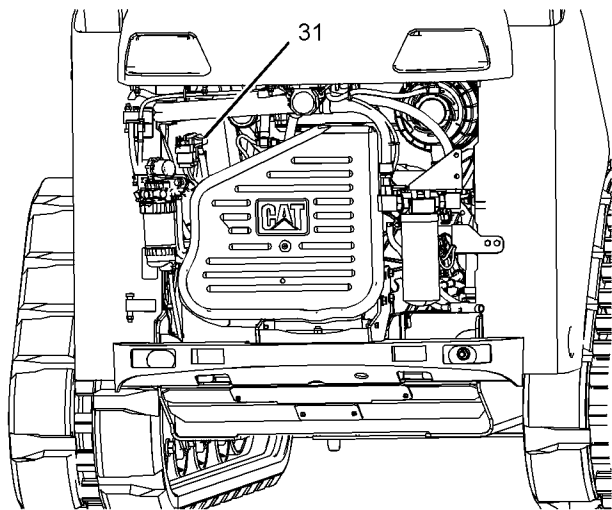
There is an additional fuse panel behind the cab on the left side of the machine.

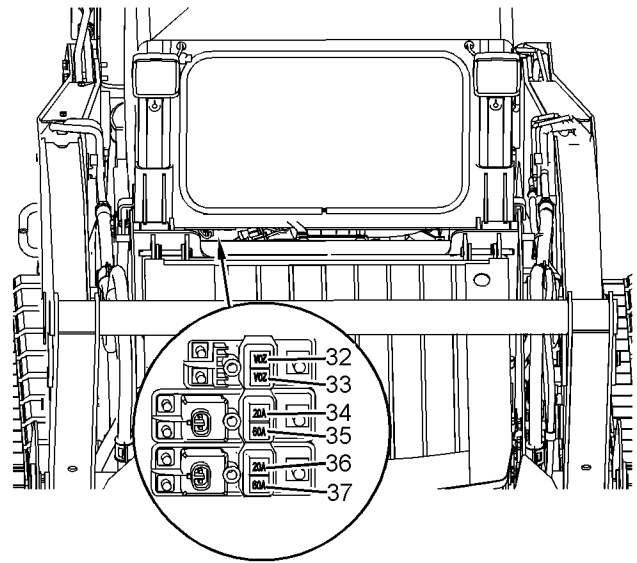

Illustration 250

g02142313

This panel has six fuses. In order to change these fuses, push up on the locking tab on the fuse cover. Pull the cover away from the back of the cab.

**32 – Ignition switch “20 A”****33 – ECM “20 A”****34 – Horn “20 A”****35 – Main power relay 1 “60 A”****36 – Miscellaneous cab accessories “20 A”**

**37 – Main power relay 2 “60 A”**

i02127331

**Headlights - Adjust**

SMCS Code: 1429-025



Illustration 251

g00714442

**Roading Lights**

Perform the following procedure in order to align the headlights:

1. Verify that the tires are inflated properly.
2. Position the machine in the following manner when you adjust the headlights:
  - a. Park the machine in a dark area.
  - b. Park the machine on level ground.
  - c. Face the machine toward a wall with 10 m (32.8 ft) between the wall and the face of the headlights.
3. Place a second person or 75 kg (165 lb) in the operator's seat.
4. Turn on the headlights.
5. Cover one headlight.
6. Loosen the other headlight clamp.
7. Move the headlight so that the headlight is pointing straight ahead. Measure the height from the ground to the center of the headlight.
8. Twist the headlight so that the upper edge of the light that is shown on the wall is two-thirds of the height from the ground to the center of the headlight. Ensure that the line of the light that is shown on the wall is horizontal.
9. Tighten the headlight clamp.

10. Repeat the process for the other headlight.

i03880891

**Hydraulic System Oil - Change**

SMCS Code: 5095-044

**Selection of the Oil Change Interval**

Your machine may be able to use a 4000 hour interval for the hydraulic oil. The hydraulic oil is in the system that is not integral to the service brakes, the clutches, the final drives, or the differentials. The standard change interval is 2000 hours. The oil should be monitored during intervals of 500 hours. The extended 4000 hour interval can be used if the following criteria are met.

**HYDO Advanced 10**

Cat HYDO Advanced 10 is the preferred oil for use in most Caterpillar machine hydraulic and hydrostatic transmission systems when ambient temperature is between  $-20^{\circ}\text{C}$  ( $-4^{\circ}\text{F}$ ) and  $40^{\circ}\text{C}$  ( $104^{\circ}\text{F}$ ). Cat HYDO Advanced 10 has an SAE viscosity grade of 10W. **Cat HYDO Advanced 10 has a 50% increase in the standard oil drain interval** (up to 3000 hours) for machine hydraulic systems over second and third choice oils when you follow the maintenance interval schedule for oil filter changes and for oil sampling that is stated in the Operation and Maintenance Manual. 6000 hour oil drain intervals are possible when using S·O·S Services oil analysis. When you switch to Cat HYDO Advanced 10, cross contamination with the previous oil should be kept to less than 10%. Consult your Cat dealer for details about the benefits from the improved performance designed into Cat HYDO Advanced 10.

**Oil Filters**

Caterpillar oil filters are recommended. The interval for changing the oil filter should be 500 hours.

**Oil**

The 6000 hour interval for changing the oil is specific to HYDO Advance 10.

The 4000 hour interval for changing the oil is for the following oil types.

- Caterpillar Hydraulic Oil (HYDO)
- Caterpillar Transmission and Drive Train Oil (TDTO)
- Caterpillar TDTO-TMS
- Caterpillar Diesel Engine Oil
- Caterpillar Biodegradable Hydraulic Oils (HEES)

- Caterpillar Multipurpose Tractor Oil (MTO)
- Heavy-duty diesel engine oils with a minimum zinc content of 900 ppm

If Caterpillar oils cannot be used, use heavy-duty oils with the following classification: Caterpillar ECF-1, API CG-4, API CF and TO-4. These oils must have a minimum zinc additive of 0.09 percent (900 ppm).

**Note:** Industrial hydraulic oils are not recommended in Caterpillar hydraulic systems.

### Monitoring the Condition of the Oil

The oil should be monitored during intervals of 500 hours. Caterpillar's standard SOS Fluids Analysis or an equivalent oil sampling program should be used.

The current guidelines for cleanliness of the oil should be observed. Refer to "Measured Data".

If an oil sampling program is not available, the standard 2000 oil change interval should be used.

### Measured Data

The following information should be monitored through sampling of the oil:

- Significant changes in wear metals should be monitored. These metals include iron, copper, chromium, lead, aluminum, and tin.
- Significant changes in the following additives should be monitored: zinc, calcium, magnesium and phosphorus.
- Contaminants should not be present. These contaminants include fuel and antifreeze. Water content should be .5 percent or less.
- The silicon level should not exceed 15 parts per million for new oil. The particle counts should be monitored.
- The recommended level of cleanliness for Caterpillar machines that are operated in the field is ISO 18/15 or cleaner. The cleanliness should be monitored by particle count analysis. The levels of contamination should not exceed the normal by more than two ISO codes. Action should be taken in order to determine the cause of the contamination. The system should be returned to the original levels of contamination.
- There should not be significant changes in sodium, silicon, copper, and potassium.
- The allowable level of oxidation is 40 percent (0.12 Abs units).

- The kinematic viscosity of 100 °C (212 °F) oil should not exceed a change of more than 2 cSt from new oil.

## Procedure for Changing the Hydraulic Oil

### NOTICE

Care must be taken to ensure that fluids are contained during performance of inspection, maintenance, testing, adjusting and repair of the product. Be prepared to collect the fluid with suitable containers before opening any compartment or disassembling any component containing fluids.

Refer to Special Publication, NENG2500, "Caterpillar Dealer Service Tool Catalog" for tools and supplies suitable to collect and contain fluids on Caterpillar products.

Dispose of all fluids according to local regulations and mandates.

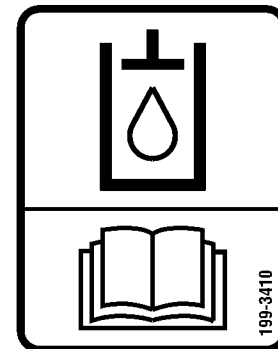

Illustration 252

g00956818

**Note:** This film is located near the hydraulic filler cap on machines that are filled with arctic oil.

Operate the machine for a few minutes in order to warm the hydraulic system oil.

### **WARNING**

**Personal injury or death can result without releasing all of the hydraulic pressure.**

**Release all the pressure from the hydraulic system before any lines are disconnected.**

Maintenance Section  
Hydraulic System Oil - Change

The machine should be on level ground. Lower the bucket to the ground and apply slight downward pressure. Engage the parking brake and stop the engine. Keep the armrest lowered. Turn the engine start switch key to the ON position. Push the parking brake switch. Move all of the joystick controls while you press several times on each side of the auxiliary hydraulic control (if equipped) in order to relieve hydraulic pressure. Move the engine start switch key to the OFF position.

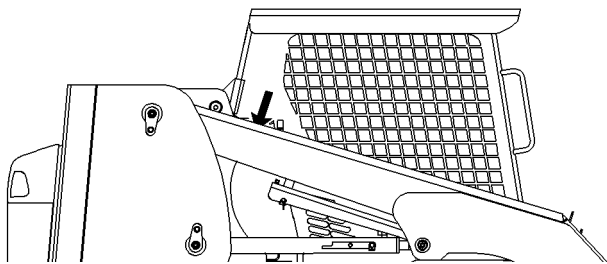

Illustration 253

g00926534

1. Remove the hydraulic tank filler cap.

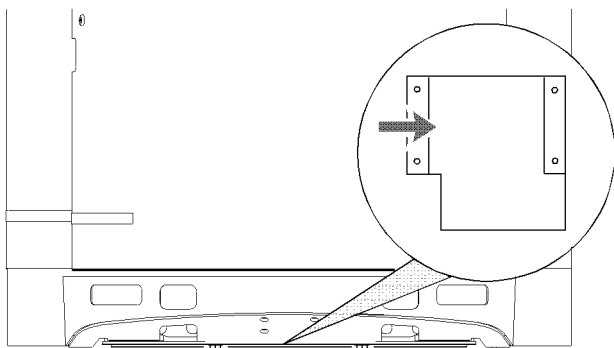

Illustration 254

g01021146

2. Remove the access panel in the belly guard underneath the machine.

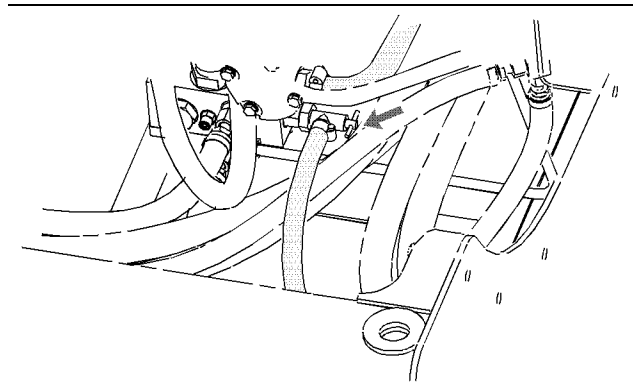

Illustration 255

g01030411

3. Remove the plug from the end of the drain hose. Pull the drain hose through the access panel in the belly guard. Open the drain valve and drain the oil into a suitable container.
4. Close the drain valve and pull the drain hose back into the machine. Install the drain plug into the drain hose.
5. Change the hydraulic system filter. Refer to Operation and Maintenance Manual, "Hydraulic System Oil Filter - Change".
6. Fill the hydraulic system oil tank. Refer to Operation and Maintenance Manual, "Lubricant Viscosities" and Operation and Maintenance Manual, "Capacities (Refill)".
7. Maintain the hydraulic oil level approximately in the middle of the sight gauge.  
Check the oil level with the loader arms in the fully lowered position.

**Note:** The oil must be free of bubbles. If bubbles are present in the oil, air is entering the hydraulic system. Inspect the suction hoses and hose clamps.

8. Install the hydraulic tank filler cap.

i03880895

## Hydraulic System Oil Filter - Replace

SMCS Code: 5068-510

### NOTICE

Care must be taken to ensure that fluids are contained during performance of inspection, maintenance, testing, adjusting and repair of the product. Be prepared to collect the fluid with suitable containers before opening any compartment or disassembling any component containing fluids.

Refer to Special Publication, NENG2500, "Caterpillar Dealer Service Tool Catalog" for tools and supplies suitable to collect and contain fluids on Caterpillar products.

Dispose of all fluids according to local regulations and mandates.

The hydraulic oil filter is located in the engine compartment.

1. Open the engine access door. Refer to Operation and Maintenance Manual, "Access Doors and Covers".

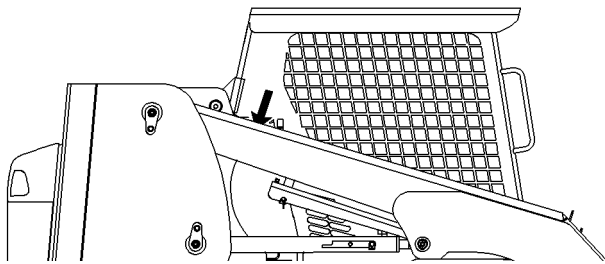

Illustration 256

g00926534

2. Remove the hydraulic tank filler cap.

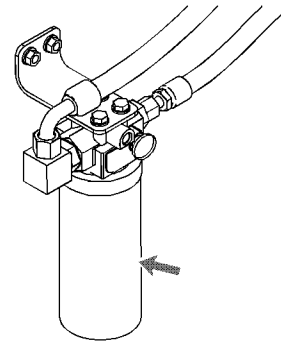

Illustration 257

g01017252

3. Remove the filter with a strap type wrench.

**Note:** Place a suitable nonconductive container under the hydraulic oil filter. Use this container in order to catch any oil that may spill from the filter or the filter element mounting base.

4. Clean the filter element mounting base. Remove any part of the filter element gasket that remains on the filter element mounting base.

5. Apply a light coat of oil to the gasket of the new filter element gasket.

6. Install a new filter hand tight until the seal of the filter contacts the base. Note the position of the index marks on the filter in relation to a fixed point on the filter base.

**Note:** There are rotation index marks on the filter that are spaced 90 degrees or 1/4 of a turn away from each other. When you tighten the filter, use the rotation index marks as a guide.

7. Tighten the filter according to the instructions that are printed on the filter. Use the index marks as a guide.

**Note:** You may need to use a Caterpillar strap wrench, or another suitable tool, in order to turn the filter to the amount that is required for final installation. Make sure that the installation tool does not damage the filter.

8. Maintain the hydraulic oil level to the middle of the sight gauge. Refer to Operation and Maintenance Manual, "Hydraulic System Oil Level - Check". **Do not overfill the hydraulic tank.**

9. Inspect the gasket on the hydraulic tank filler cap for damage. Replace the hydraulic tank filler cap, if necessary. Install the hydraulic tank filler cap.

10. Close the engine access door.

i01957050

i02920120

## Hydraulic System Oil Level - Check

SMCS Code: 5095-535-FLV

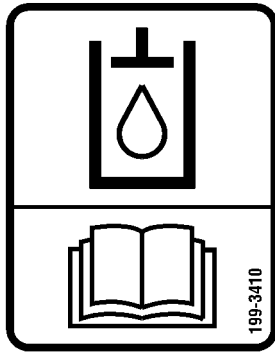

Illustration 258

g00956818

**Note:** This film is located near the hydraulic filler cap on machines that are filled with synthetic oil.

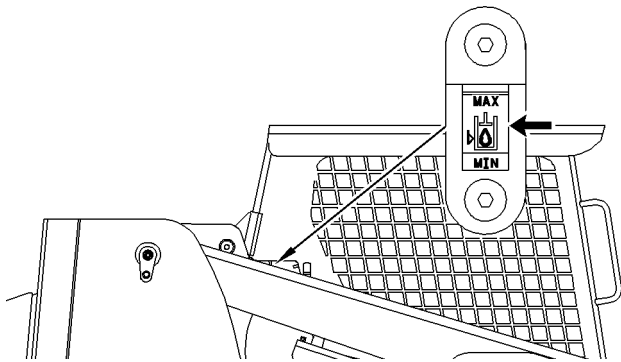

Illustration 259

g00926177

1. Park the machine on level ground.
2. Lower the work tool to the ground. Turn off the engine.
3. Wait for about five minutes before checking the level of the hydraulic oil.
4. Maintain the oil level to the middle of the sight gauge. **Do not overfill the hydraulic tank.**

## Hydraulic System Oil Sample - Obtain

SMCS Code: 5050-008; 7542-008

Open the rear access door. Refer to Operation and Maintenance Manual, "Access Doors and Covers" for information about the rear door.

Raise the radiator. Refer to Operation and Maintenance Manual, "Radiator Tilting" for information about the radiator.

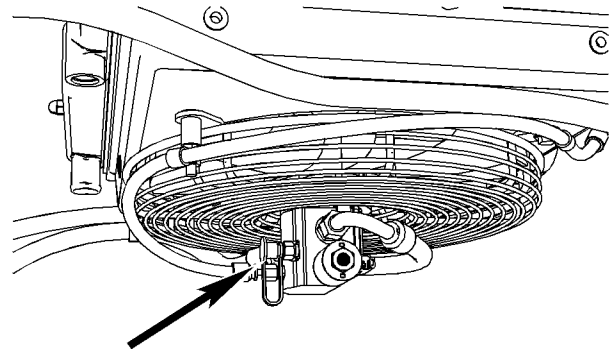

Illustration 260

g01280271

The sampling port for the hydraulic oil is located on the fan motor.

i01957078

## Lift Arm and Cylinder Linkage - Lubricate

SMCS Code: 5102-086-BD; 6107-086-BD

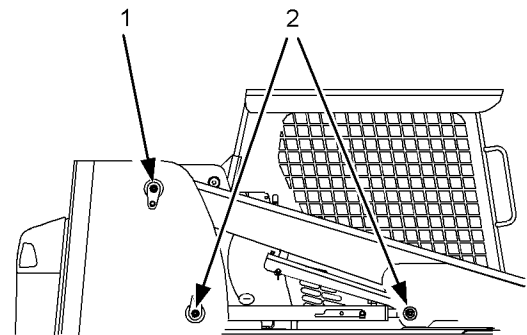

Illustration 261

g01017352

Radial Lift

i02106227

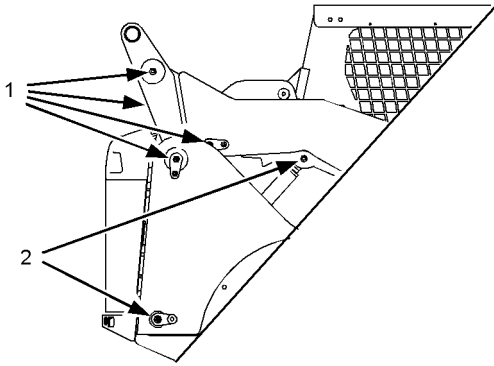

Illustration 262

g01017361

**Extended Reach**

Apply lubricant to the grease fittings (1) for the lift arm linkage.

Apply lubricant to the grease fittings (2) for the lift cylinder bearings.

Repeat the process for the opposite side of the machine.

i01963869

**Lower Machine Frame - Clean****SMCS Code:** 7050-070

1. Tilt the cab upward. Refer to Operation and Maintenance Manual, "Cab Tilting".

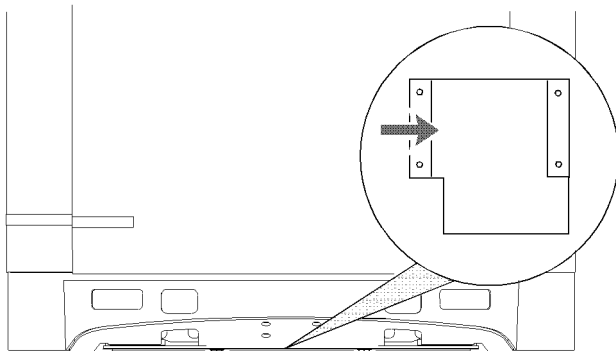

Illustration 263

g01020241

2. Remove the access panel in the frame that is located underneath the machine.
3. Remove any debris or dirt from the inside of the frame.
4. Reinstall the access panel and tilt the cab downward.

**Oil Filter - Inspect****SMCS Code:** 1308-507; 3067-507; 5068-507**Inspect a Used Filter for Debris**

Illustration 264

g00100013

The element is shown with debris.

Use a filter cutter to cut the filter element open. Spread apart the pleats and inspect the element for metal and for other debris. An excessive amount of debris in the filter element can indicate a possible failure.

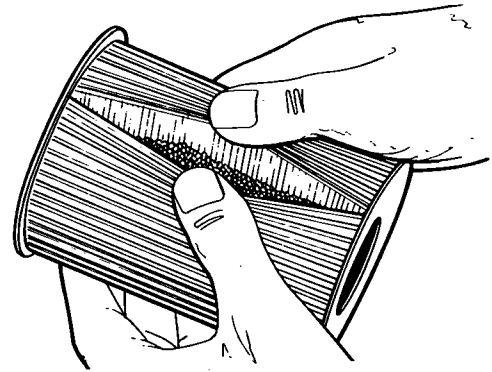
If metals are found in the filter element, a magnet can be used to differentiate between ferrous metals and nonferrous metals.

Ferrous metals can indicate wear on steel parts and on cast iron parts.

Nonferrous metals can indicate wear on the aluminum parts of the engine such as main bearings, rod bearings, or turbocharger bearings.

Small amounts of debris may be found in the filter element. This could be caused by friction and by normal wear. Consult your Caterpillar dealer in order to arrange for further analysis if an excessive amount of debris is found.

Using an oil filter element that is not recommended by Caterpillar can result in severe engine damage to engine bearings, to the crankshaft, and to other parts. This can result in larger particles in unfiltered oil. The particles could enter the lubricating system and the particles could cause damage.

i02634143

## Quick Coupler - Clean/Inspect

SMCS Code: 6129-040; 6129-070

### **! WARNING**

Personal injury or death can result from improperly checking for a leak.

Always use a board or cardboard when checking for a leak. Escaping air or fluid under pressure, even a pin-hole size leak, can penetrate body tissue causing serious injury, and possible death.

If fluid is injected into your skin, it must be treated immediately by a doctor familiar with this type of injury.

**Note:** Do not weld on the quick coupler without consulting your Caterpillar dealer.

1. Clean the quick coupler prior to inspection in order to properly inspect the quick coupler.

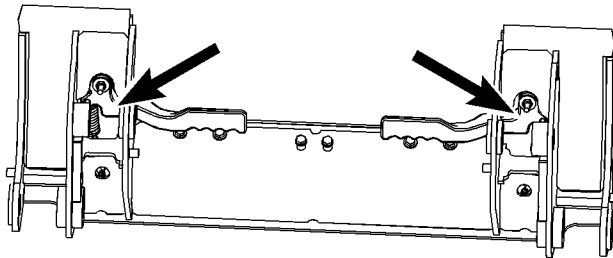

Illustration 265

g01322438

This is the back side of the quick coupler. The lift arm and the tilt cylinder are removed for clarity.

2. Tilt the quick coupler all the way forward in order to clean the debris away from the pins.
3. Move the quick coupler levers. Ensure that the levers are not bent or broken.
4. Make sure that the coupler pins extend through the bottom of the quick coupler assembly. Check the pins for wear and check the pins for damage.
5. Check the top edges of the quick coupler assembly for wear or for damage. Check the face of the quick coupler assembly for wear or for damage.
6. Inspect the components inside the quick coupler for the following problems: loose bolts, oil leaks, broken parts, missing parts and cracked components
7. Inspect the hydraulic lines and the hydraulic fittings for damage or for wear. Repair any worn components or replace any worn components. Repair any leaking components.
8. Inspect the steel material of the quick coupler for cracks.

**Note:** Perform all repairs before placing the quick coupler back into operation.

i03886849

## Radiator Core - Clean

SMCS Code: 1353-070-KO

The radiator is located at the rear of the machine above the engine compartment.

1. Stop the engine. Open the engine access door. Refer to Operation and Maintenance Manual, "Access Doors and Covers".
2. Tilt the radiator guard upward. Refer to Operation and Maintenance Manual, "Radiator Tilting".

### **! WARNING**

Personal injury can result from air pressure.

Personal injury can result without following proper procedure. When using pressure air, wear a protective face shield and protective clothing.

Maximum air pressure at the nozzle must be less than 205 kPa (30 psi) for cleaning purposes.

### NOTICE

When you are using compressed air or high pressure water to clean the radiator fins, ensure that the air or water is directed parallel to the fins. If the compressed air or high pressure water is not directed parallel to the radiator fins, the radiator fins could be bent or damaged.

i06849898

**Note:** Pressurized air is the preferred method for removing loose debris. Hold the nozzle approximately 6 mm (0.25 inch) away from the fins. Slowly move the air nozzle in a direction that is parallel with the tubes. The air nozzle should point in the opposite direction of the flow of the fan. This will remove debris that is between the tubes. Pressurized water may also be used for cleaning. The maximum water pressure for cleaning purposes must be less than 275 kPa (40 psi). Use pressurized water in order to soften mud. Use a degreaser and steam for removal of oil and grease. Wash the core with detergent and hot water. Thoroughly rinse the core with clean water.

3. Clean the radiator core from the top toward the fan.

**Note:** If parts of the cooling system appear to be damaged or if parts of the cooling system are repaired, a leak test is highly recommended. Consult your Caterpillar dealer for the most current information about the cooling system.

4. After cleaning, start the engine and accelerate the engine to high idle rpm. This will help in the removal of debris and drying of the core. Stop the engine. Use a light bulb behind the core in order to inspect the core for cleanliness. Repeat the cleaning, if necessary.
5. Inspect the fins and tubes of the radiator core for damage. Some fins and tubes may be worn from abrasive material that has passed through the radiator core. Bent fins may be opened with a "comb".

---

#### NOTICE

Do not clean a rotating fan with high pressure water. Fan blade failure can result.

---

6. Remove any dirt or debris from the fan, the fan hub, the oil cooler, the radiator guard and the fan guard.

**Note:** Dirt or debris on the cooling fan can cause an imbalance.

7. Tilt the radiator guard downward.
8. Close the engine access door.

## Refrigerant Dryer - Replace (If Equipped)

SMCS Code: 7322-510

### WARNING

**Personal injury can result from contact with refrigerant.**

**Contact with refrigerant can cause frost bite. Keep face and hands away to help prevent injury.**

**Protective goggles must always be worn when refrigerant lines are opened, even if the gauges indicate the system is empty of refrigerant.**

**Always use precaution when a fitting is removed. Slowly loosen the fitting. If the system is still under pressure, release it slowly in a well ventilated area.**

**Personal injury or death can result from inhaling refrigerant through a lit cigarette.**

**Inhaling air conditioner refrigerant gas through a lit cigarette or other smoking method or inhaling fumes released from a flame contacting air conditioner refrigerant gas, can cause bodily harm or death.**

**Do not smoke when servicing air conditioners or wherever refrigerant gas may be present.**

**Use a certified recovery and recycling cart to properly remove the refrigerant from the air conditioning system.**

---

#### NOTICE

If the refrigerant system has been open to the outside air (without being plugged) for more than 30 minutes, the receiver-dryer must be replaced. Moisture will enter an open refrigerant system and cause corrosion which will lead to component failure.

---

Refer to Service Manual, UENR4125, "Air Conditioning and Heating R-134a For All Caterpillar Machines" for the proper procedure to change the receiver-dryer assembly and for the procedure to reclaim the refrigerant gas.

A qualified mechanic should perform this service because special refrigerant handling tools and training are required.

See your Cat dealer for this service.

i02798931

## Rollover Protective Structure (ROPS) and Falling Object Protective Structure (FOPS) - Inspect

SMCS Code: 7323-040; 7325-040

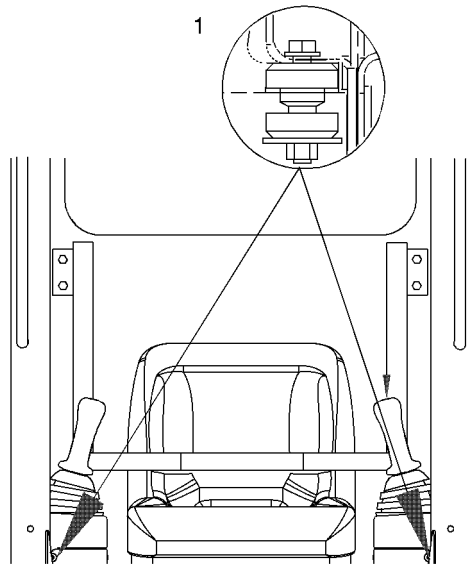

Illustration 266

g01022156

(1) Front ROPS retaining bolt (one bolt per side)

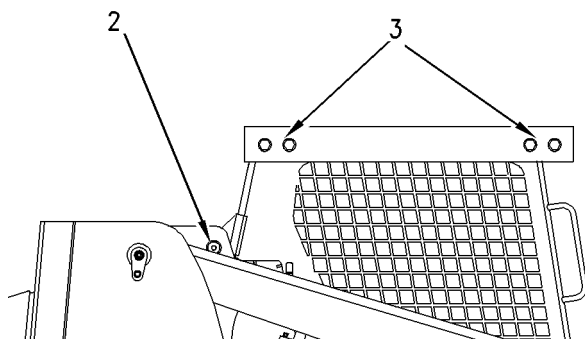

Illustration 267

g00925477

(2) Rear ROPS retaining bolt (one bolt per side)  
 (3) Retaining bolts for the FOPS 2

**Note:** There is a total of four retaining bolts for the ROPS. There is a total of eight retaining bolts for the FOPS 2.

1. Inspect the ROPS and the FOPS for loose bolts. Tighten the bolts (1) to the following torque  $125 \pm 10 \text{ N}\cdot\text{m}$  ( $92 \pm 7 \text{ lb ft}$ ). Tighten the bolts (2) to the following torque  $55 \pm 5 \text{ N}\cdot\text{m}$  ( $41 \pm 4 \text{ lb ft}$ ). Tighten the bolts (3) to the following torque  $240 \pm 40 \text{ N}\cdot\text{m}$  ( $177 \pm 30 \text{ lb ft}$ ). ROPS and the FOPS for damaged bolts or missing bolts. Replace any damaged bolts or missing bolts with original equipment parts only.
2. Operate the machine on a rough surface. Replace the ROPS mounting supports if the ROPS emits a noise. Replace the ROPS mounting supports if the ROPS rattles.

Do not straighten the ROPS or the FOPS. Do not repair the ROPS or the FOPS by welding reinforcement plates to the ROPS or the FOPS.

Consult your Caterpillar dealer for repair of any cracks in the ROPS or the FOPS.

Inspect the Flying Object Guard (if equipped) for damage.

Consult your Caterpillar dealer for repair of any cracks in the Flying Object Guard.

i04423622

## Seat Belt - Inspect

SMCS Code: 7327-040

Always inspect the condition of the seat belt and the condition of the seat belt mounting hardware before you operate the machine. Replace any parts that are damaged or worn before you operate the machine.



Illustration 268

g02620101

Typical example

Inspect buckle (1) for wear or for damage. If the buckle is worn or damaged, replace the seat belt.

Inspect seat belt (2) for webbing that is worn or frayed. Replace the seat belt if the webbing is worn or frayed.

Inspect all seat belt mounting hardware for wear or for damage. Replace any mounting hardware that is worn or damaged. Make sure that the mounting bolts are tight.

If your machine is equipped with a seat belt extension, also perform this inspection procedure for the seat belt extension.

Contact your Cat dealer for the replacement of the seat belt and the mounting hardware.

**Note:** The seat belt should be replaced within 3 years of the date of installation. A date of installation label is attached to the seat belt retractor and buckle. If the date of installation label is missing, replace belt within 3 years from the year of manufacture as indicated on belt webbing label, buckle housing, or installation tags (non-retractable belts).

i06891605

## Seat Belt - Replace

**SMCS Code:** 7327-510

The seat belt should be replaced within 3 years of the date of installation. A date of installation label is attached to the seat belt retractor and buckle. If the date of installation label is missing, replace belt within 3 years from the year of manufacture as indicated on belt webbing label, buckle housing, or installation tags (non-retractable belts).

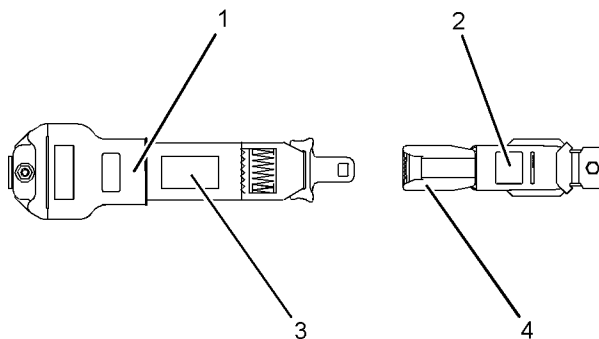

Illustration 269

g01152685

### Typical Example

- (1) Date of installation (retractor)
- (2) Date of installation (buckle)
- (3) Year of manufacture (tag) (fully extended web)
- (4) Year of manufacture (underside) (buckle)

Consult your Cat dealer for the replacement of the seat belt and the mounting hardware.

Determine age of new seat belt before installing on seat. A manufacture label is on belt webbing and imprinted on belt buckle. Do not exceed install by date on label.

Complete seat belt system should be installed with new mounting hardware.

Date of installation labels should be marked and affixed to the seat belt retractor and buckle.

**Note:** Date of installation labels should be permanently marked by punch (retractable belt) or stamp (non-retractable belt).

If your machine is equipped with a seat belt extension, also perform this replacement procedure for the seat belt extension.

i04776649

## Sprocket - Inspect

**SMCS Code:** 4164-040

**S/N:** HR21-Up

**S/N:** KB31-Up

**S/N:** B7H1-Up

**S/N:** PWK1-Up

**S/N:** ESL1-Up

**S/N:** TSL1-Up

**S/N:** DXZ1-Up

**S/N:** YYZ1-Up

**Note:** Operating the machine in conditions that are muddy or sandy will cause accelerated wear on the sprocket and other undercarriage components. Clean the undercarriage of the machine daily in order to maximize component life.

## Sprocket Inspection for 247B3 and 257B3

**Note:** Sleeves that do not meet the minimum thickness or sleeves that do not turn freely may cause unnecessary wear on the drive lugs on the rubber track.

## Remove the Sprocket

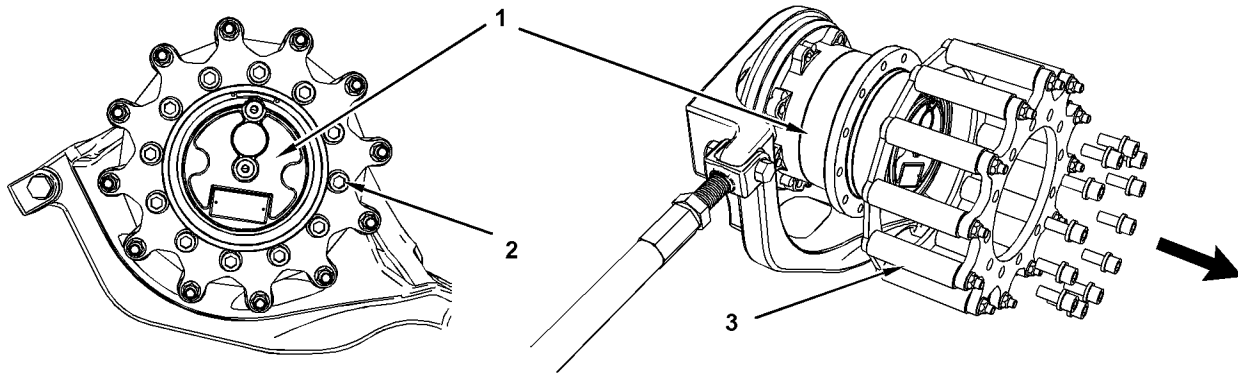

Illustration 270

g01394413

(1) Drive motor

(2) Bolts and washers

(3) Sprocket assembly

**Note:** In order to service the sprocket, the tracks must be loosened. Refer to Operation and Maintenance Manual, "Track (Rubber) - Inspect/Adjust" for the procedure.

1. Remove the 12 bolts and the 12 washers that hold the sprocket assembly to the drive motor.
2. Slide the sprocket assembly off the drive motor.

## Sleeves and Rings

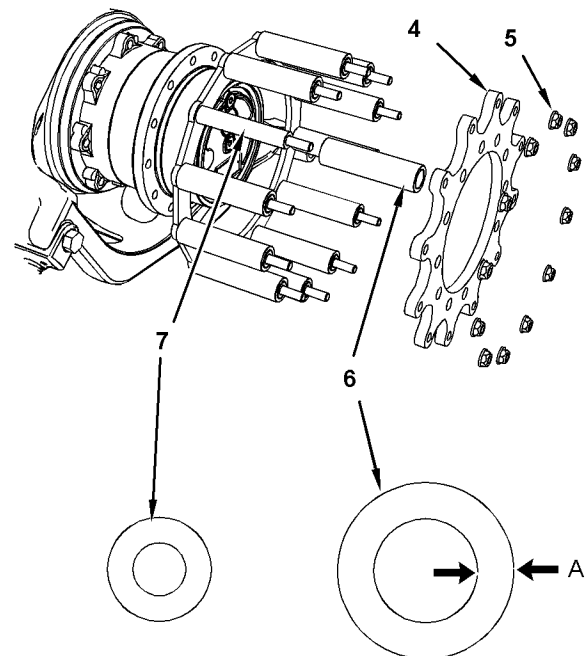

Illustration 271

g01394415

(4) Sprocket mounting ring

(5) Washers and Locknuts

(6) Outer sleeve

(7) Inner sleeve

The sprocket is equipped with two types of sleeves.

- Inner Sleeves (6)

- Outer sleeves (5)

The outer sleeves are free to rotate on the inner sleeves. The sleeves are held in position by the sprocket mounting ring.

**Note:** There are many parts in the sprocket assembly. Remove the sprocket completely from the machine in order to work on the sprocket. Use a clean, flat surface in order to disassemble the sprocket and assemble the sprocket.

1. Remove the 12 locknuts and washers that hold the sprocket mounting ring in place.
2. Remove the ring.
3. Remove the outer sleeves and the inner sleeves.
4. Measure thickness (A) for the outer sleeves. If the thickness of the outer sleeves measures less than 3 mm (0.12 inch), replace the sleeves. Sleeves that do not meet the minimum thickness or sleeves that do not turn freely may cause unnecessary wear on the drive lugs on the rubber track.
5. When you replace the outer sleeves, rotate the inner sleeves for 180°. If the inner sleeves have already been rotated, replace the inner sleeves.
6. Repeat steps 2 through 5 for each set of sleeves.
7. The sprocket mounting rings of the drive sprocket will wear from the rotation of the outer sleeves. Measure the thickness of the inner rings and outer rings. If the thickness of the inner ring or outer ring measures less than 4.75 mm (0.19 inch), replace the ring.
8. Install the sleeves and the rings.
9. Install the new locknuts. **Do not reuse the locknuts.** Tighten the locknuts to a torque of  $70 \pm 5 \text{ N}\cdot\text{m}$  ( $51.6 \pm 3.7 \text{ lb ft}$ ) in a star pattern. Turn the nuts an additional 120 degrees  $\pm 5$  degrees in the same star pattern.
10. Install the sprocket on the drive motor. Tighten the bolts to a torque of  $270 \pm 40 \text{ N}\cdot\text{m}$  ( $199 \pm 30 \text{ lb ft}$ ).

## Track

Tighten the track to the proper tension. Refer to Operation and Maintenance Manual, "Track (Rubber) - Inspect/Adjust" for the procedure.

## Sprocket Inspection for 259B3

### Inspect

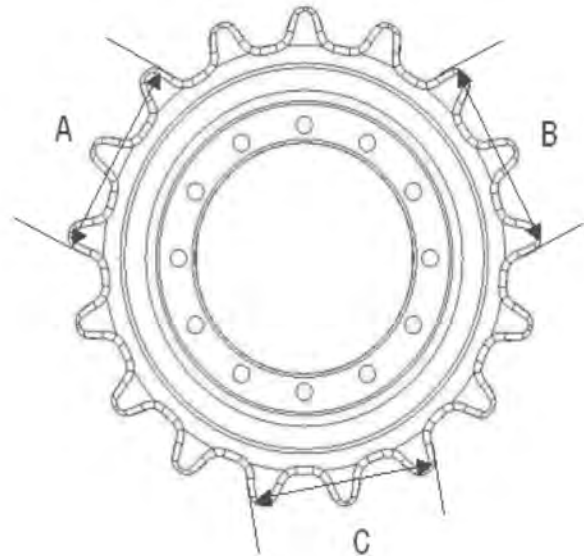

Illustration 272

g02789983

1. Measure the sprocket teeth in three places as shown in illustration 272.
2. Calculate the average of the 3 measurements to determine the 50% wear limit.
3. If the average of 3 measurements is less than 178 mm (7 inch), relocate the sprocket to the opposite side of the machine. Follow the steps in the "Relocate" section. If the average of 3 measurements is less than 165 mm (6.5 inch), then replace the sprocket. Follow the steps in the "Replace" section.

### Relocate

1. Remove the track on both sides of the machine.
2. Remove the sprocket on the left side of the machine. Move the sprocket to the right side.
3. Remove the sprocket on the right side of the machine. Move the sprocket to the left side.
4. Install the sprockets. Tighten the bolts to the proper torque.
5. Install the track on both sides of the machine.

## Replace

1. Remove the track on both sides of the machine.
2. Remove the sprocket on the left side of the machine. Install the new sprocket.
3. Tighten the bolts to the proper torque.
4. Remove the sprocket on the right side of the machine. Install the new sprocket.
5. Tighten the bolts to the proper torque.
6. Install the track on both sides of the machine.

i02125302

## Sprocket Retaining Nuts - Check

**SMCS Code:** 4164-535-NT

**S/N:** KB31-Up

**S/N:** B7H1-Up

**S/N:** ESL1-Up

**S/N:** TSL1-Up

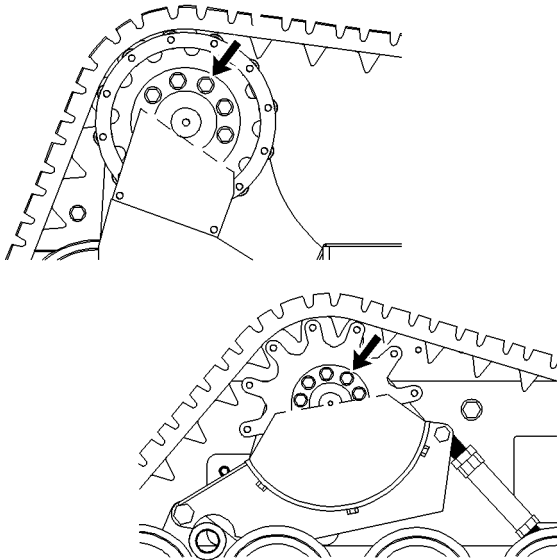

Illustration 273

g00953040

Check the torque on the nuts for new sprockets or for sprockets that have been reinstalled after every ten service hours until the specified torque is maintained.

Check the nuts on both sprockets. Use a star pattern when you tighten the nuts.

Tighten the nuts for the 247 and 257 to the following torque  $175 \pm 30 \text{ N}\cdot\text{m}$  ( $129 \pm 22 \text{ lb ft}$ ).

Tighten the nuts for the 267, 277 and 287 to the following torque  $270 \pm 40 \text{ N}\cdot\text{m}$  ( $199 \pm 30 \text{ lb ft}$ ).

i02790866

## Sprocket Sleeve - Inspect

**SMCS Code:** 4164-040-ZV

**S/N:** KB31-Up

**S/N:** B7H1-Up

**S/N:** ESL1-Up

**S/N:** TSL1-Up

**Note:** Operating the machine in conditions that are muddy or sandy will cause accelerated wear on the sprocket and other undercarriage components. It is important to clean the undercarriage of the machine daily in order to maximize component life. Sleeves that do not meet the minimum thickness or sleeves that do not turn freely may cause unnecessary wear on the drive lugs on the rubber track.

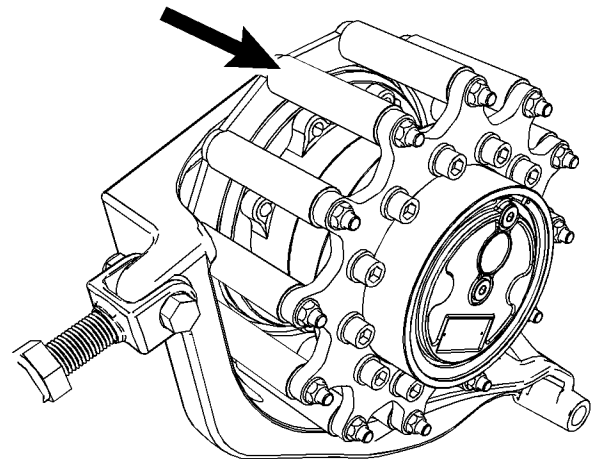

Illustration 274

g01394383

Check the outer sleeves in order to ensure that the sleeves rotate freely. If the sleeves do not rotate freely, refer to Operation and Maintenance Manual, "Sprocket - Inspect" for information about the inspection of the sprocket assembly.

i01878236

## Tilt Cylinder Bearings and Bucket Linkage Bearings - Lubricate

**SMCS Code:** 5104-086-BD; 6107-086-BD

Wipe all of the grease fittings before you apply lubricant.

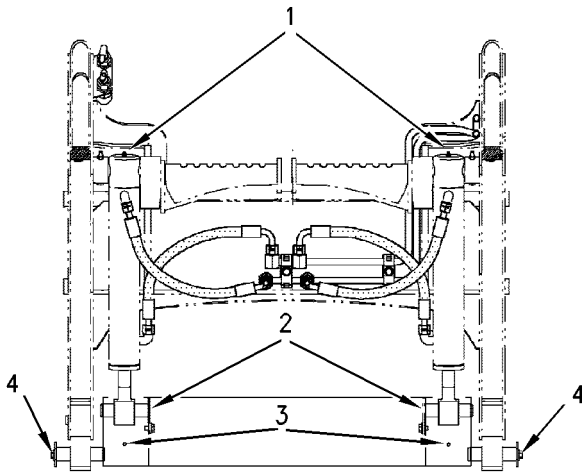

Illustration 275

g00955895

**Note:** Lubricate the fittings with the loader lift arms in the fully lowered position.

Apply lubricant to the grease fittings (1) for the upper bearings for the tilt cylinders.

Apply lubricant to the grease fittings (2) for the lower bearings for the tilt cylinders.

Apply lubricant to the grease fittings (3) for the coupler engagement pins.

Apply lubricant to the grease fitting (4) for the pivot pin of the quick coupler assembly.

There are a total of 8 grease fittings.

i05327146

## Tire Inflation - Check

**SMCS Code:** 4203-535-AI

**S/N:** AS21-Up

**S/N:** HR21-Up

**S/N:** CD31-Up

**S/N:** SNA1-Up

**S/N:** MWD1-Up

**S/N:** A9H1-Up

**S/N:** PWK1-Up

**S/N:** TNK1-Up

**S/N:** JXM1-Up

**S/N:** DSN1–Up**S/N:** SRS1–Up**S/N:** DXZ1–Up

Table 45

| Tire size and recommended inflation pressure (cold) for Cat Skid Steer Loader B-Series Models |           |            |                  |       |                     |       |                               |       |                       |       |
|---|-----------|------------|------------------|-------|---------------------|-------|-------------------------------|-------|-----------------------|-------|
| Model   | Tire Size | Ply Rating | GalaxyBeefy Baby |       | Caterpillar Premium |       | Caterpillar XD (Extreme Duty) |       | GoodyearSure Grip Lug |       |
| <b>216B Series 3</b>  | 10x16.5   | 8, 10      | 205kPa           | 30psi | 205kPa              | 30psi | 240kPa                        | 35psi | 310kPa                | 45psi |
| <b>226B Series 3</b>  | 10x16.5   | 8, 10      | 205kPa           | 30psi | 205kPa              | 30psi | 240kPa                        | 35psi | 310kPa                | 45psi |
| <b>236B Series 3</b>  | 12x16.5   | 10, 14     | 240kPa           | 35psi | 240kPa              | 35psi | 275kPa                        | 40psi | -                     | -     |
| <b>242B Series 3</b>  | 10x16.5   | 8, 10      | 310kPa           | 45psi | 314kPa              | 45psi | 345kPa                        | 50psi | 310kPa                | 45psi |
|   | 12x16.5   | 10, 14     | 240kPa           | 35psi | 240kPa              | 35psi | 275kPa                        | 40psi | -                     | -     |
| <b>252B Series 3</b>  | 12x16.5   | 10, 14     | 380kPa           | 55psi | 380kPa              | 55psi | 414kPa                        | 60psi | -                     | -     |

The above recommended tire inflation pressure is based on a standard machine with the following conditions:

- 75 kg operator
- Typical operating conditions
- Full fluid levels
- The machine weight and the weight of the work tool must not exceed the weight limit on the "ROPS" certification.

**Note:** Consult your Cat dealer if your machine is experiencing excessive tire slippage. Slippage may be the result of tire wear.

Inflate the tires, if necessary.

## Tire Inflation with Air

### **WARNING**

Use a self-attaching inflation chuck and stand behind the tread when inflating a tire.

Proper inflation equipment, and training in using the equipment, are necessary to avoid overinflation. A tire blowout or rim failure can result from improper or misused equipment.

Before inflating tire, install on the machine or put tire in restraining device.

### NOTICE

Set the tire inflation equipment regulator at no more than 140 kPa (20 psi) over the recommended tire pressure.

## Tire Inflation with Nitrogen

Caterpillar recommends the use of dry nitrogen gas for tire inflation and for tire pressure adjustments. This includes all machines with rubber tires. Nitrogen is an inert gas that will not aid combustion inside the tire.

### **WARNING**

Proper nitrogen inflation equipment, and training in using the equipment, are necessary to avoid over inflation. A tire blowout or rim failure can result from improper or misused equipment and personal injury or death can occur.

A tire blowout and/or rim failure can occur if the inflation equipment is not used correctly, due to the fact that a fully charged nitrogen cylinder's pressure is approximately 15000 kPa (2200 psi).

There are other benefits to using nitrogen in addition to reducing the risk of an explosion. The use of nitrogen for tire inflation lessens the slow oxidation of the rubber. Use of nitrogen also slows gradual tire deterioration. This is especially important for tires that are expected to have a long service life of at least four years. Nitrogen reduces the corrosion of rim components. Nitrogen also reduces problems that result from disassembly.

**WARNING**

**A tire blowout or a rim failure can cause personal injury.**

**Use a self-attaching inflation chuck and stand behind the tread when inflating a tire, to prevent personal injury.**

**NOTICE**

Set the tire inflation equipment regulator at no more than 140 kPa (20 psi) over the recommended tire pressure.

Use 6V-4040 Inflation Group or an equivalent inflation group to inflate tires with a nitrogen gas cylinder.

**Reference:** For tire inflation instructions, refer to Special Instruction, SMHS7867, "Nitrogen Tire Inflation Group".

For nitrogen inflation, use the same tire pressures that are used for air inflation. Consult your tire dealer for operating pressures.

i02970641

## Track (Rubber) - Inspect/Adjust

**SMCS Code:** 4197; 4198-040; 4198-025

**S/N:** KB31-Up

**S/N:** B7H1-Up

**S/N:** ESL1-Up

**S/N:** TSL1-Up

Periodic adjustment of the track tension is necessary in order to avoid damage to the tracks. Maintaining the tracks at the proper tension will maximize the service life of the undercarriage components. The undercarriage components include the sleeves of the drive sprocket, the rings of the drive sprocket, the wheels, and the track.

**NOTICE**

Do not overtighten the tracks. Tracks that are too tight can cause premature failure of the tracks. Tracks that are too tight can cause power loss and bearing failures.

Tracks that are too loose increase the possibility of the track derailing or the drive lugs mis-feeding on the drive sprocket. In aggressive operating conditions, occasional mis-feeding is normal. If consistent mis-feeding is observed, ensure that the track tension is set to the recommended specification. If the track tension is set to the recommended specification and mis-feeding is still observed, then your application may require a tighter track tension. Increase the track tension until consistent mis-feeding is no longer observed.

The intervals for track tension vary depending on the following conditions: the machine application, the operator, the soil conditions, the climate and the condition of the undercarriage components. Operators are responsible for basic visual inspections of the track tension on a daily basis.

## Track Adjustment

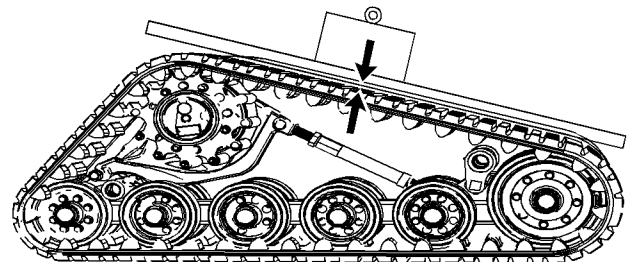

Illustration 276

g01393224

1. Place approximately 45 kg (100 lb) between the drive sprocket and the idlers. Place a straight edge across the drive sprocket and idlers. Measure the track sag between the bottom of the straight edge and the top of the track. **The track sag should be set at 12 mm (0.5 inch).** If the track needs adjustment proceed with the following steps.

Maintenance Section  
Track (Rubber) - Remove/Replace

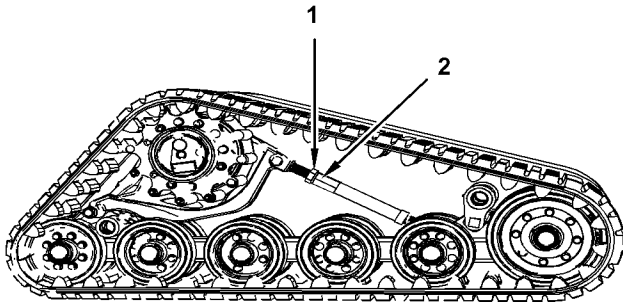

Illustration 277

g01393226

2. Loosen the jam nut (1).
3. Turn the adjuster (2) in order to raise or lower the drive sprocket.
4. Inspect the hoses. Ensure that the hoses are not kinked. If the hoses are kinked, loosen the clamp and move the hoses so that the hoses are not kinked.

**Note:** In order to detension the track for removal, fully lower the drive sprocket.

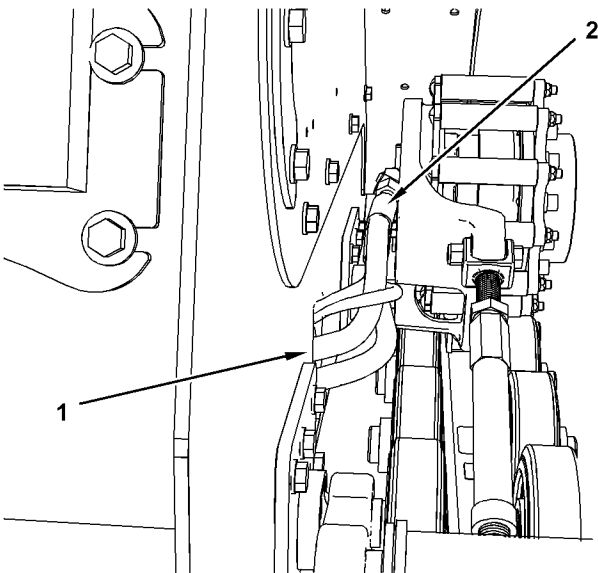

Illustration 278

g01497493

Note that the rubber track is removed for clarity.

- (1) Hoses at the frame  
(2) Fittings on final drive

**Note:** The hoses should not be under tension. The fittings at the drive motor may leak if there is tension on the hoses.

5. Tighten the jam nut to the following torque  
270 ± 40 N·m (199 ± 30 lb ft).
6. Recheck the track tension.
7. Check the hoses. Ensure that there is no tension in the hoses. Ensure that the hoses are not kinked. Tighten the hose clamps at the frame.

**Note:** Too much slack in the hoses may allow the hoses to contact other components. Not enough slack may strain hose connections at the drive motor.

i03880897

## Track (Rubber) - Remove/Replace (MTL)

**SMCS Code:** 4197; 4198-011; 4198-510

**S/N:** KB31–Up

**S/N:** B7H1–Up

**S/N:** ESL1–Up

**S/N:** TSL1–Up

### Removing the Track

1. Position the machine on firm, level ground.
2. Remove any work tool that is attached to the quick coupler.
3. Raise the loader arms and install the brace for the loader lift arm. Refer to Operation and Maintenance Manual, "Loader Lift Arm Brace Operation".

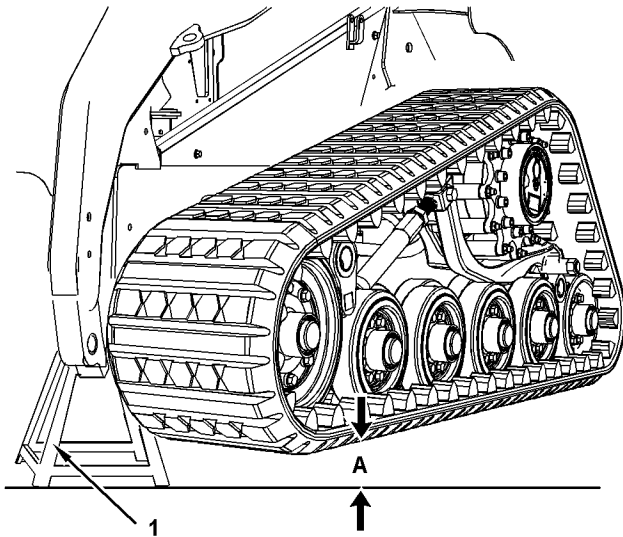

Illustration 279

g01393193

4. Use an appropriate floor jack in order to lift the machine off the ground. Use appropriate jack stands (1) in order to block up the machine. Raise the machine until tracks are approximately 50 mm (2.0 inch) (A) off the ground.
5. Detension the track. Refer to Operation and Maintenance Manual, "Track (Rubber) - Inspect/Adjust".

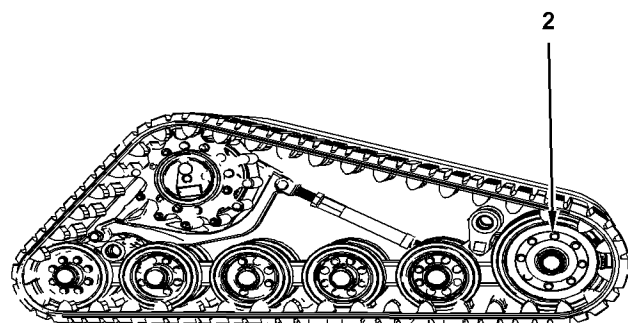

Illustration 280

g01393194

6. Remove the front idler wheel. Refer to Operation and Maintenance Manual, "Bogie and Idler - Inspect/Replace" for the procedure to remove the idler wheels.
7. If necessary, lubricate the remaining front idler wheel and the inside of the track in order to ease the removal of the track.

8. Grasp the track on top of the front idler. Pull the track forward and pull the track away from the frame. Slide the drive lugs past the inside front idler wheels.
9. Lift the track off the drive sprocket and pull the track away from the rear idler wheels.

## Installing the Track

1. Slide the track onto the drive sprocket.
2. Position the rear of the track so that the drive lugs are aligned between the rear idler wheels.
3. Pull all of the slack forward and make sure that the drive lugs are properly meshed with the drive sprocket. This will provide the maximum amount of slack to aid with installation across the front idler.
4. Lubricate the idler wheels and the inside of the track in order to ease the installation of the track.
5. Pull the track over the front idler wheel.
6. Install the front idler wheel. Refer to Operation and Maintenance Manual, "Bogie and Idler - Inspect/Replace" for the procedure to install the idler wheel.
7. Tension the track. Refer to Operation and Maintenance Manual, "Track (Rubber) - Inspect/Adjust".

i03880903

## Track (Rubber) - Remove/Replace (CTL)

**SMCS Code:** 4197; 4198-011; 4198-510

**S/N:** HR21-Up

**S/N:** PWK1-Up

**S/N:** DXZ1-Up

**S/N:** YYZ1-Up

## Removing the Track

1. Position the machine on firm, level ground.
2. Remove any work tool that is attached to the quick coupler.
3. Raise the loader arms and install the brace for the loader lift arm. Refer to Operation and Maintenance Manual, "Loader Lift Arm Brace Operation".

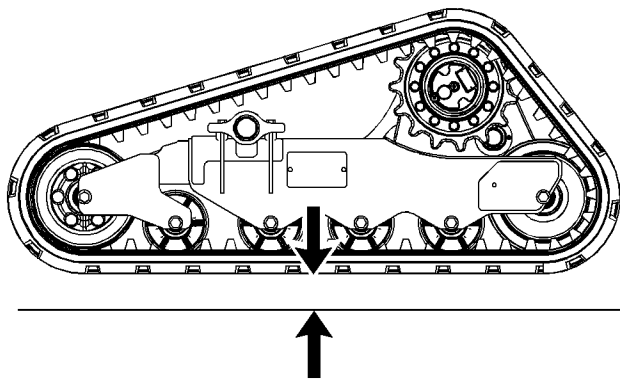

Illustration 281

g02142365

4. Use an appropriate floor jack in order to lift the machine off the ground. Use appropriate jack stands in order to block up the machine. Raise the machine until tracks are approximately 50 mm (2.0 inch) (A) off the ground.
5. Detension the track. Refer to Operation and Maintenance Manual, "Track - Inspect/Adjust".

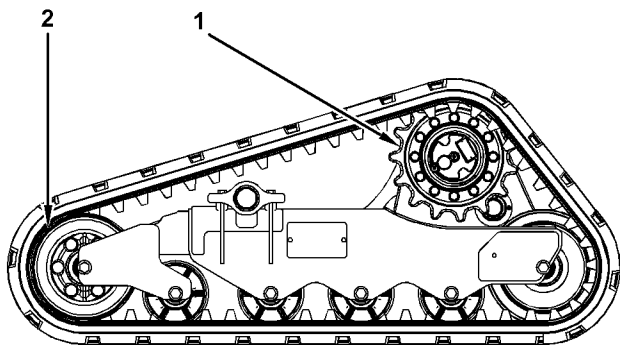

Illustration 282

g02142368

- (1) Final Drive Sprocket  
(2) Front idler wheel

**Note:** The approximate weight of the track is 247 kg (545 lb).

6. Use a suitable lifting device. Lift the track at MIDDLE position between the front idler and the final drive sprocket until the front idler collapses fully.

**Note:** It is helpful to support the bottom of the track in order to maximize the slack between the front idler and the drive sprocket.

7. Keep the track supported with a hoist. Lift the track over the flange of the front idler so that the inner track guides clear flanges.

8. Lift the track over the sprocket with a suitable lifting device. The inner guides need to clear the sprocket teeth.
9. Lift the track over the rear idler. The inner track guides need to clear the rear idler.

## Installing the Track

**Note:** The approximate weight of the track is 247 kg (545 lb).

1. Use a suitable lifting device. Slide the track onto the rear idler so that the inner track guides straddle the rear idler. If your machine is equipped with an idler with dual flanges, the inner track guides must seat between the flanges.
2. Pull the track forward in order to ensure that the track guides are fully seated on the rear idler.
3. Lift the track over the final drive sprocket so that the inner track guides straddle the sprocket teeth. The sprocket teeth should seat in the openings in the middle of the track.
4. Pull all of the slack forward. This will provide the maximum amount of slack to aid with installation across the front idlers.

**Note:** It is helpful to support the bottom of the track in order to maximize the slack. This will help with installation.

5. Position the track so that the inner track guides seat between the flanges on the front idler.
6. Tension the track. Refer to Operation and Maintenance Manual, "Track - Inspect/Adjust" for the procedure.

i03898486

## Track - Inspect/Adjust (CTL)

**SMCS Code:** 4170-040; 4170-025

**S/N:** HR21-Up

**S/N:** PWK1-Up

**S/N:** DXZ1-Up

**S/N:** YYZ1-Up

Periodic adjustment of the track tension is necessary in order to avoid damage to the tracks. Maintaining the tracks at the proper tension will maximize the service life of the undercarriage components. The undercarriage components include the final drive sprocket, idlers, rollers, and the track.

**NOTICE**

Do not overtighten the tracks. Tracks that are too tight can cause premature failure of the tracks. Tracks that are too tight can cause power loss and bearing failures.

Tracks that are too loose increase the possibility of the track derailing or the drive lugs mis-feeding on the drive sprocket. In aggressive operating conditions, occasional mis-feeding is normal. If consistent mis-feeding is observed, ensure that the track tension is set to the recommended specification. If the track tension is set to the recommended specification and mis-feeding is still observed, then your application may require a tighter track tension. Increase the track tension until consistent mis-feeding is no longer observed.

The intervals for track tension vary depending on the following conditions: the machine application, the operator, the soil conditions, the climate and the condition of the undercarriage components. Operators are responsible for basic visual inspections of the track tension on a daily basis.

**Inspect**

Illustration 283

g02142344

Support the machine so that the track is a minimum of 51 mm (2 inches) above the ground.

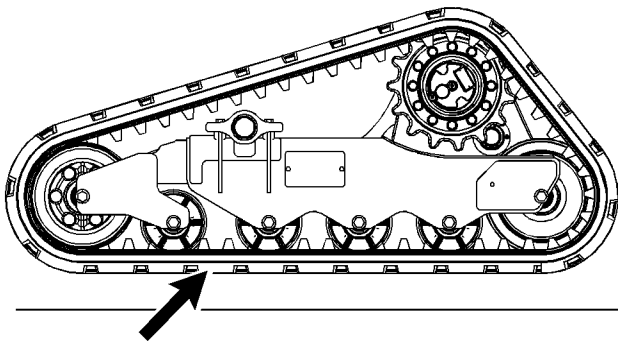
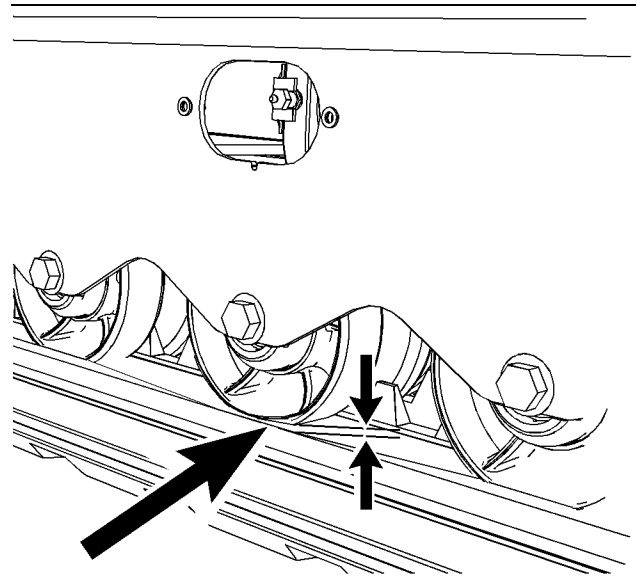

Illustration 284

g02142348

Measure the track sag at the third roller from the front. Measure the distance from the bottom surface of the flange on the roller to the inside top surface of the track. The minimum track sag should be 15 mm (0.59 inch). The maximum track sag should be 25 mm (0.98 inch).

**Track Adjustment**

Illustration 285

g02142349

1. In order to adjust the track, remove the access panel on the side of the undercarriage.

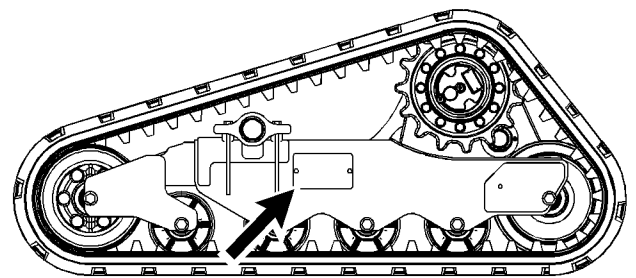
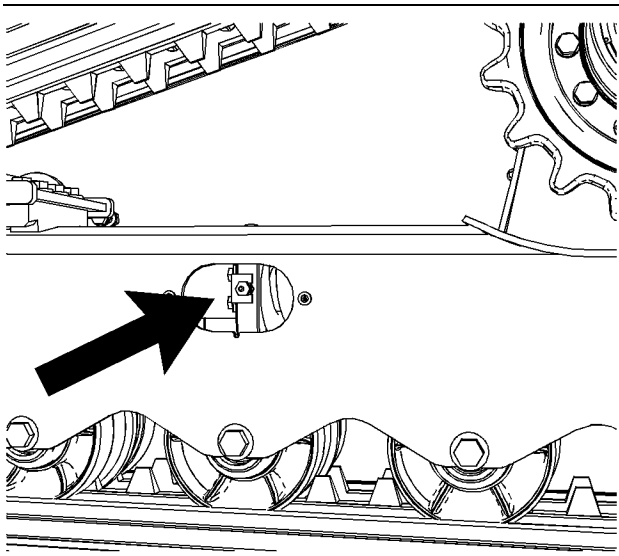

Illustration 286

g02142351

2. Pressurized grease in a cylinder is used in order to provide tension on the track. Use a grease gun in order to apply grease to the grease fitting on the cylinder. This will tighten the track.
3. Recheck the track tension.
4. Replace the access panel when the 15 mm (0.59 inch) sag is achieved.

## Detension the track

### **⚠ WARNING**

**Personal injury or death can result from grease under pressure.**

**Grease coming out of the relief valve under pressure can penetrate the body causing injury or death.**

**Do not watch the relief valve to see if grease is escaping. Watch the track or track adjustment cylinder to see if the track is being loosened.**

**Loosen the relief valve one turn only.**

**If track does not loosen, close the relief valve and contact your Caterpillar dealer.**

**Note:** Many operations for maintenance of the undercarriage require the track to be loosened.

1. In order to detension the track, remove the access panel on the side of the undercarriage.

2. Loosen the grease fitting with a suitable device. Loosen the grease fitting carefully until the track begins to loosen.

**Note:** Catch the grease in a suitable container. Dispose of the grease in accordance with all applicable regulations.

**Note:** One turn should be the maximum.

3. Tighten the grease fitting to a torque of  $74 \pm 14 \text{ N}\cdot\text{m}$  ( $55 \pm 10 \text{ lb ft}$ ) when the desired track tension is reached.

4. Replace the access panel.

i07719244

## Track Roller and Idler - Inspect/Replace (CTL - Steel Track)

**SMCS Code:** 4159-510; 4159-040; 4180-040; 4180-510

**S/N:** HR21-Up

**S/N:** PWK1-Up

**S/N:** DXZ1-Up

**S/N:** YYZ1-Up

## Inspect

Clean the undercarriage before inspecting the idlers and the rollers.

Inspect the idlers and the rollers for damage and wear.

The idlers and the rollers should be replaced when the damage to the wheels adversely affects machine performance.

**Note:** The idlers and the rollers contain oil. The idlers and the rollers are sealed for life. Periodically, inspect the idlers and the rollers for leaks or for excessive end play. Contact your Caterpillar dealer if either leaks or excessive end play is found.

i01203574

## Wheel Nuts - Tighten

**SMCS Code:** 4210-527

**S/N:** AS21-Up

**S/N:** HR21-Up

**S/N:** CD31-Up

**S/N:** SNA1-Up

**S/N:** MWD1–Up**S/N:** A9H1–Up**S/N:** PWK1–Up**S/N:** TNK1–Up**S/N:** JXM1–Up**S/N:** DSN1–Up**S/N:** SRS1–Up**S/N:** DXZ1–Up

Check the torque on new wheels or reinstalled wheels after every one service hour until the specified torque is maintained. After the specified torque is maintained, check the torque on the nuts after every ten service hours or every day.

Check the nuts on all four wheels. Use a star pattern when you are tightening the nuts.

The torque specifications are given in the following table.

Table 46

| Tightening Torque for Wheels |                             |
|------------------------------|-----------------------------|
| Airboss and Solid Tires      | 163 ± 7 N·m (120 ± 5 lb ft) |
| Pneumatic Tires              | 149 ± 7 N·m (110 ± 5 lb ft) |

i03880912

## Window Washer Reservoir - Fill (If Equipped)

**SMCS Code:** 7306-544-KE**NOTICE**

When operating in freezing temperatures, use Caterpillar nonfreezing window washer solvent or equivalent. System damage can result from freezing.

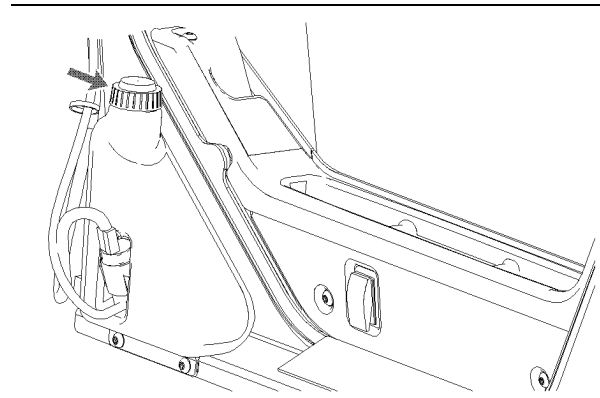

Illustration 287

g01027404

The reservoir for the window washer solvent is located inside the cab on the left side.

Fill the reservoir with window washer solvent.

**Note:** Window washer solvent with isopropyl alcohol is recommended.

i02810705

## Window Wiper - Inspect/ Replace (If Equipped)

**SMCS Code:** 7305-510; 7305-040

Inspect the condition of the front window wiper blade. Replace the window wiper blade if the window wiper blade is worn or damaged. If the window wiper blade streaks the window, replace the window wiper blade.

i03880915

## Windows - Clean

**SMCS Code:** 7310-070

Use commercially available window cleaning solutions in order to clean the windows. The side windows of the cab can be removed for cleaning. Refer to the following procedure in order to remove the side windows.

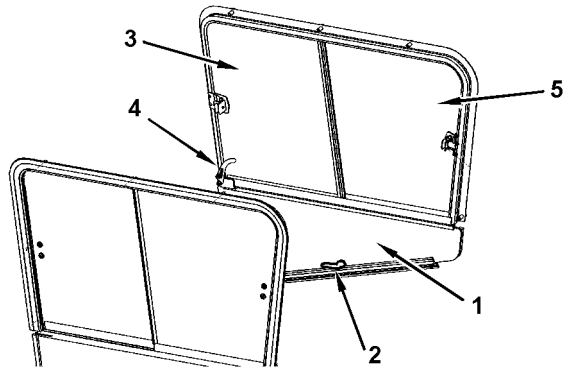

Illustration 288

g01026875

1. Release the latch (2) in order to remove the window (1). Pull downward on the window in order to remove the window. Pull outward on the window in order to remove the window.
2. Release the latch (4) in order to remove the window (3). Pivot the channel for the window downward. Pull the window outward in order to remove the window.
3. Slide the window (5) forward. Pull the window outward in order to remove the window.

## Polycarbonate Front Door

**Note: Do not wipe the window dry.** Do not use paper towels. This may scratch the finish of the polycarbonate windows over time.

For cleaning your polycarbonate top window use a soft cloth, a sponge, or a chamois. Use any of the following cleaners:

- soap and water
- isopropyl alcohol
- kerosene
- denatured alcohol
- commercially available window cleaning solutions

Apply the cleaning solution liberally. Wipe the surface.

i02728710

## Work Tool - Lubricate

SMCS Code: 6700-086

### Multipurpose Bucket

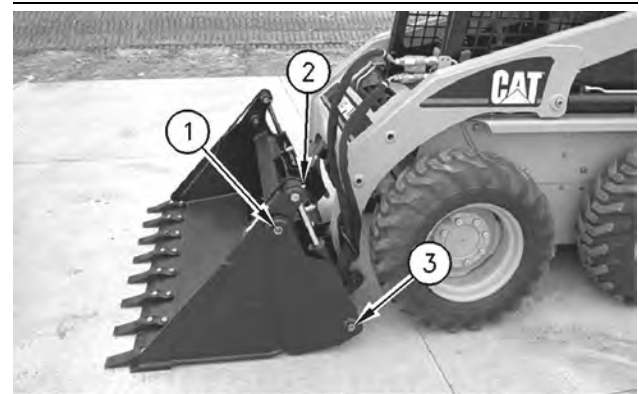

Illustration 289

g00534457

Apply lubricant to the grease fitting (1) for the pivot pin of the apron.

Apply lubricant to the grease fitting (2) for the rod end of the multipurpose bucket cylinder.

Apply lubricant to the grease fitting (3) for the head end of the multipurpose bucket cylinder.

Repeat for the other side of the bucket.

There are six grease fittings.

## Utility Grapple Tools

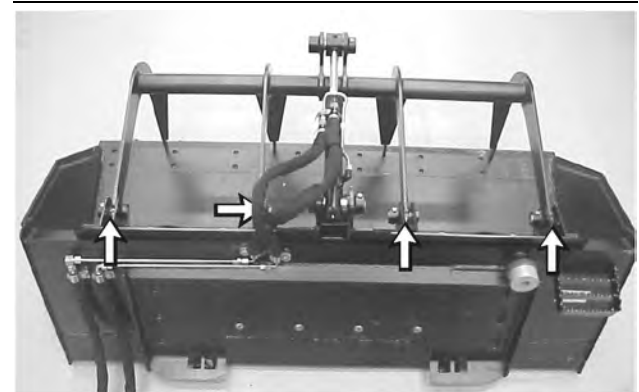

Illustration 290

g00647980

Apply lubricant to the four grease fittings for the grapples.

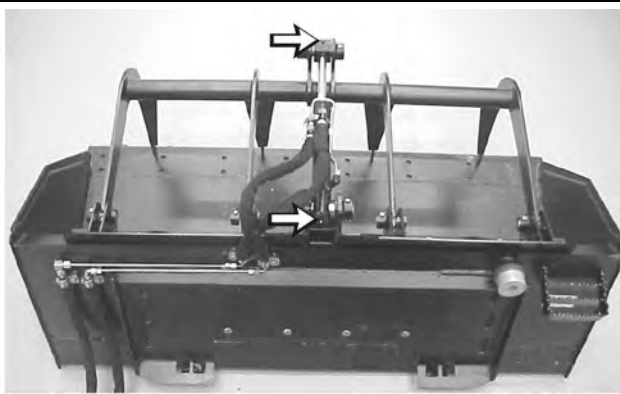

Illustration 291

g00647988

Apply lubricant to the two fittings for the grapple cylinder.

There are six grease fittings.

### Industrial Grapple Tools

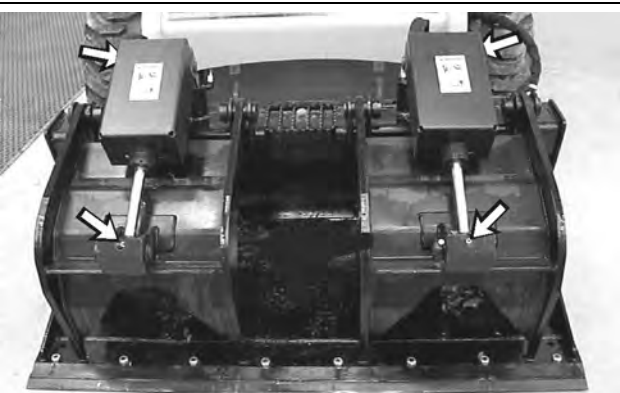

Illustration 292

g00645995

Apply lubricant to the four grease fittings for the fork cylinders.



Illustration 293

g00646004

Apply lubricant to the four grease fittings for the two forks.

There are eight grease fittings.

### Grapple Rake

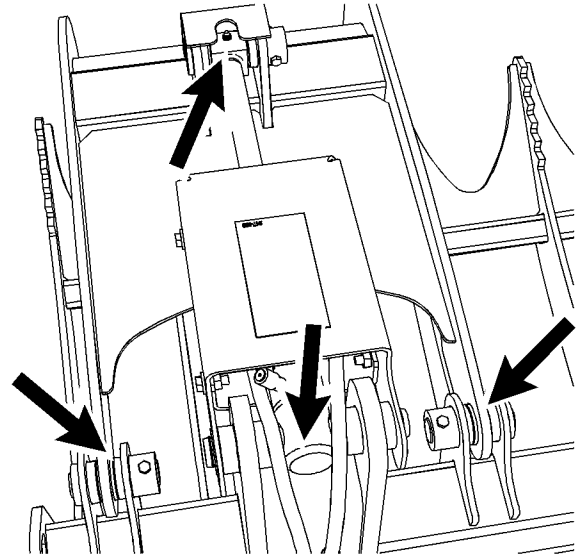

Illustration 294

g01368386

Apply lubricant to the four grease fittings for the grapple cylinders.

Apply lubricant to the four grease fittings for the two grapples.

There are eight grease fittings.

### Angle Blade



Illustration 295

g00648033

Apply lubricant to the grease fitting on the rod end of the angle cylinder.

Maintenance Section  
Work Tool Guard and Reflector - Inspect/Replace

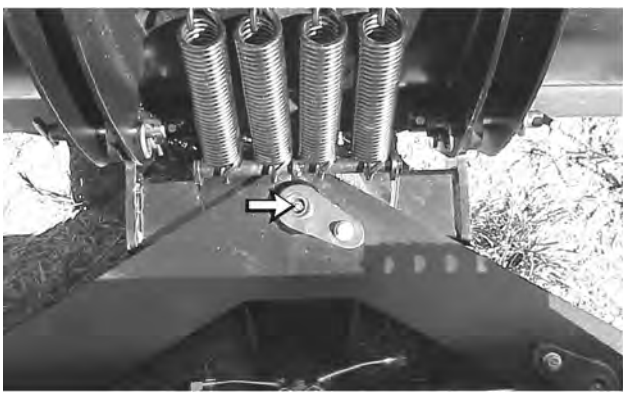

Illustration 296

g00648037

Apply lubricant to the grease fitting on the horizontal pivot point of the blade.

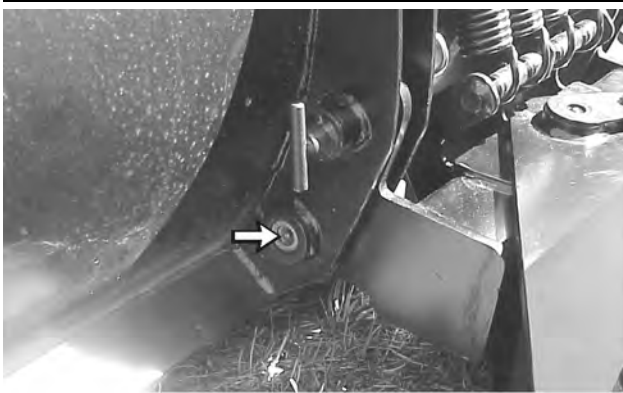

Illustration 297

g00648038

Apply lubricant to the grease fitting on the vertical pivot point of the blade. Repeat for opposite side of the blade.

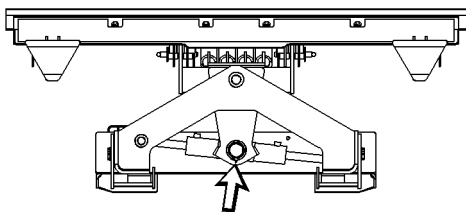

Illustration 298

g00677570

This is a bottom view of the angle blade.

Apply lubricant to the grease fitting on the pivot point of the cylinder.

There are five grease fittings.

## Dozer Blade

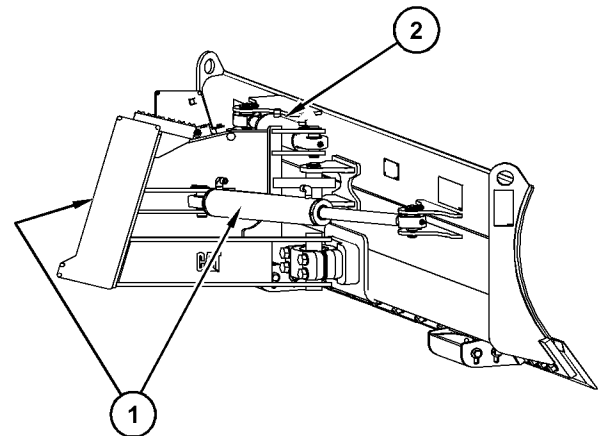

Illustration 299

g01073259

Apply lubricant to the grease fitting on both ends of the right hand angle cylinder (1). Repeat for opposite side of the blade.

Apply lubricant to the grease fitting on the pivot points on each end of the tilt cylinder (2).

There are six grease fittings.

i03881935

## Work Tool Guard and Reflector - Inspect/Replace

SMCS Code: 6700

Ensure that all safety reflectors are clean. Ensure that all safety reflectors are not damaged. When you clean the safety reflectors, use a cloth, water and soap. Do not use solvent, gasoline, or other harsh chemicals to clean the safety reflectors. Solvents, gasoline, or harsh chemicals could loosen the adhesive that secures the safety reflectors. Loose adhesive will allow the safety reflectors to fall.

Replace any safety reflector or replace any guards that are damaged, or missing. If a safety reflector is attached to a part that is replaced, install a safety reflector on the replacement part. Any Caterpillar dealer can provide new safety reflectors.

i01809997

## Work Tool Mounting Bracket - Inspect

**SMCS Code:** 6700-040-BK

Illustration 300

g00925058

Inspect upper angled plate (1) and ensure that the plate is not bent or otherwise damaged. Inspect holes (2) for wear and for damage. Inspect lower angled plate (3) and ensure that the plate is not bent or otherwise damaged. If any wear is suspected or any damage is suspected, consult your Caterpillar dealer before you use the work tool.

## Reference Information Section

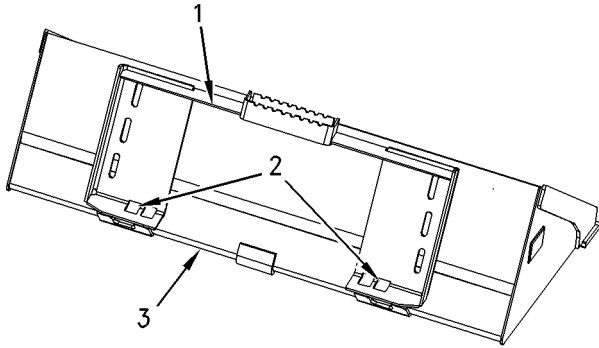
### Reference Materials

i04353090

### Reference Material

SMCS Code: 1000; 7000

### Cooling System

Special Publication, PMEP5027, "Label - ELC Radiator Label"

Special Publication, PEHJ0067, "Product Data Sheet for Caterpillar ELC"

Special Publication, PEHP9554, "Product Data Sheet for Caterpillar DEAC (Diesel Engine Antifreeze/Coolant)"

Special Publication, SEBD0518, "Know Your Cooling System"

Special Publication, SEBD0970, "Coolant and Your Engine"

### Grease

Data Sheet, NEHP6010, "Cat Ultra 5Moly Grease (NLGI grade 1 and grade 2)"

Data Sheet, NEHP6011, "Cat Arctic Platinum Grease (NLGI grade 0)"

Data Sheet, NEHP6012, "Cat Desert Gold Grease (NLGI grade 2)"

Data Sheet, NEHP6015, "Cat High Speed Ball Bearing Grease (NLGI grade 2)"

Special Publication, PEGJ0035, "Grease Selection Guide"

Data Sheet, PEHJ0088, "Cat Multipurpose Grease (NLGI grade 2)"

Data Sheet, PEHP0002, "Cat Advanced 3Moly Grease (NLGI grade 2)"

### Hydraulic Oil

Special Publication, PEGP6028, "Caterpillar Hydraulic Systems Management Guide"

Special Publication, PEHJ0182, "Product Data Sheet for Caterpillar HYDO Advanced 10"

Special Publication, PEHP6047, "Product Data Sheet for Caterpillar Biodegradable Hydraulic Oil (HEES)"

### Operation and Maintenance Manuals

Operation and Maintenance Manual, SEBU5898, "Cold Weather Recommendations"

Operation and Maintenance Manual, SEBU8257, "The European Union Physical Agents (Vibration) Directive 2002/44/EC"

Operation and Maintenance Manual, SMBU6981, "Emissions Control Warranty Information"

### Miscellaneous Publications

Power Train Disassembly and Assembly, RENR6422, "Tire and Rim - Remove and Install"

Special Publication, PECP9067, "One Safe Source"

Special Publication, PEDP9131, "Fluid Contamination - The Silent Thief"

Special Publication, PEWJ0074, "Cat Filter &amp; Fluid Application Guide"

Special Publication, SEBD0400, "Dictionary of Pictographic Symbols"

Special Publication, SEBD0717, "Diesel Fuels and Your Engine"

Special Publication, SEBF1015, "Improving Component Durability - Final Drives and Differentials"

Special Publication, SEBU6250, "Caterpillar Machine Fluid Recommendations"

Special Publication, SEBU5898, "Cold Weather Recommendations"

Special Publication, SENR5664, "Air Conditioning and Heater R-134a for All Caterpillar Machines"

Special Publication, SENR9620, "Improving Fuel System Durability"

Special Publication, SMBU6981, "Emissions Control Warranty Information"

Special Instruction, SMHS7867, "Nitrogen Tire Inflation Group"

Special Publication, REHS1199, "Installation Procedure for the Multi Terrain Loader Track Guide"

Undercarriage Reconditioning Bulletin, SEBF8501, "Undercarriage Reconditioning Guide"

### Oil

Special Publication, PEHP3050, "Product Data Sheet for Caterpillar Multipurpose Tractor Oil (MTO)"

Special Publication, PEHP6001, "How to Take a Good Oil Sample"

Special Publication, PEHJ0007, "Product Data Sheet for Caterpillar Arctic TDTO (SAE 0W-20) (synthetic blend)"

Special Publication, PEHJ0008, "Product Data Sheet for Caterpillar Arctic DEO (SAE 0W-30)"

Special Publication, PEHJ0030, "Product Data Sheet for Caterpillar Synthetic Gear Oil (SAE 75W-140)"

Special Publication, PEHJ0059, "Product Data Sheet for Caterpillar DEO (SAE 10W-30)"

Special Publication, PEHP7506, "Product Data Sheet for Caterpillar TDTO (SAE 10W, SAE 30, SAE 50)"

Special Publication, PEHP7508, "Product Data Sheet for Caterpillar Gear Oil (GO) (SAE 80W-90 and SAE 85W-140)"

Special Publication, PEHP7062, "Product Data Sheet for Caterpillar DEO Synthetic (SAE 5W-40)"

Special Publication, PEHP9530, "Product Data Sheet for Caterpillar FDAO (SAE 60)"

Special Publication, PEHP9570, "Product Data Sheet for Caterpillar FDAO Synthetic (Multigrade)"

Special Publication, PELJ0179, "Caterpillar Engine Crankcase Fluid-1 Specifications (Cat ECF-1)"

Special Publication, PEHP8035, "Product Data Sheet for TDTO Transmission Multi-Season (TMS)"

Special Publication, SEBD0640, "Oil and Your Engine"

## ROPS/FOPS Structure

Special Publication, SEBD1587, "What ROPS/FOPS Certification Means"

Special Publication, SEHS6929, "Inspection, Maintenance and Repair of ROPS and Attachment Installation Guidelines"

## Safety Information

Safety Manual, SEBU7224, "Safety Manual"

Operation and Maintenance Manual, SEBU8257, "The European Union Physical Agents (Vibration) Directive 2002/44/EC"

## S·O·S Information

Special Publication, PEDP7036, "S·O·S Services"

Special Publication, PEHP7052, "Making the Most of S·O·S Services"

Special Publication, PEHP7057, "S·O·S Coolant Analysis"

Special Publication, PEHP7076, "Understanding S·O·S Services Tests"

## Product Link

Systems Operation, Troubleshooting, Testing and Adjusting, RENR7911, "Product Link 121 SR/321SR"

Systems Operation, Troubleshooting, Testing and Adjusting, RENR5885, "Product Link 151/201"

Special Instruction, REHS2365, "An Installation Guide for the Product Link PL121SR and for the PL300"

## Specifications Manuals

Specifications Manual, SENR3130, "Torque Specifications"

## Tools

Special Publication, NENG2500, "Caterpillar Dealer Service Tool Catalog"

## Additional Reference Material

SAE J183, "Classification" This can normally be found in the SAE handbook.

SAE J313, "Diesel Fuels" This can be found in the SAE handbook. Also, this publication can be obtained from your local technological society, from your local library, or from your local college.

SAE J754, "Nomenclature" This can normally be found in the SAE handbook.

Engine Manufacturers Association, "Engine Fluids Data Book"

Engine Manufacturers Association  
Two North LaSalle Street, Suite 2200  
Chicago, Illinois USA 60602  
E-mail: [ema@enginemanufacturers.org](mailto:ema@enginemanufacturers.org)  
(312) 827-8700  
Facsimile: (312) 827-8737

i07162619

## Caterpillar Approved Work Tools

**SMCS Code:** 6700

Only use Cat approved work tools on this machine.

**Note:** Do not use a Cat work tool on a machine that is not approved by Cat.

Reference Information Section  
Caterpillar Approved Work Tools

**Note:** A Debris Barrier Kit is required for use in applications which create airborne debris. Consult you Cat dealer for information about this kit.

Use of the following equipment may create airborne debris:

- mulching head
- brush cutter
- hammers
- recycling of paper products
- certain agriculture applications

**Note:** See your Cat dealer for work tools and for work tool attachments that are approved for roading.

**Note:** The combination of Water Tank, Backhoe Loader, and Hydraulic Hammer exceeds the recommended load rating.

Table 47

| Cat Approved Work Tools for Skid Steer Loaders |       |       |             |       |             |       |       |       |       |             |       |             |
|--|-------|-------|-------------|-------|-------------|-------|-------|-------|-------|-------------|-------|-------------|
| Work Tool                                      | 216B3 | 226B3 | 226B3<br>HF | 242B3 | 242B3<br>HF | 236B3 | 252B3 | 247B3 | 257B3 | 257B3<br>HF | 259B3 | 259B3<br>HF |
| General Purpose Bucket 1524 mm (60 inch)       | C     | C     | C           | C     | C           | C     | C     | C     | C     | C           | C     | C           |
| General Purpose Bucket 1676 mm (66 inch)       | C     | C     | C           | C     | C           | C     | C     | C     | C     | C           | C     | C           |
| General Purpose Bucket 1829 mm (72 inch)       | C     | C     | C           | C     | C           | C     | C     | C     | C     | C           | C     | C           |
| General Purpose Bucket 1981 mm (78 inch)       | C     | C     | C           | C     | C           | C     | C     | C     | C     | C           | C     | C           |
| General Purpose Bucket 2133 mm (84 inch)       | C     | C     | C           | C     | C           | C     | C     | C     | C     | C           | C     | C           |
| Multipurpose Bucket 1524 mm (60 inch)          | C     | C     | C           | C     | C           | C     | C     | C     | C     | C           | C     | C           |
| Multipurpose Bucket 1676 mm (66 inch)/tpara>   | C     | C     | C           | C     | C           | C     | C     | C     | C     | C           | C     | C           |
| Multipurpose Bucket 1829 mm (72 inch)          | C     | C     | C           | C     | C           | C     | C     | C     | C     | C           | C     | C           |

(continued)

(Table 47, contd)

| Cat Approved Work Tools for Skid Steer Loaders |       |       |          |       |          |       |       |       |       |          |       |          |
|--|-------|-------|----------|-------|----------|-------|-------|-------|-------|----------|-------|----------|
| Work Tool                                      | 216B3 | 226B3 | 226B3 HF | 242B3 | 242B3 HF | 236B3 | 252B3 | 247B3 | 257B3 | 257B3 HF | 259B3 | 259B3 HF |
| Multipurpose Bucket 1981 mm (78 inch)          | C     | C     | C        | C     | C        | C     | C     | C     | C     | C        | C     | C        |
| Multipurpose Bucket 2133 mm (84 inch)          | C     | C     | C        | C     | C        | C     | C     | C     | C     | C        | C     | C        |
| Dirt Bucket 1372 mm (54 inch)                  | C     | C     | C        | C     | C        | C     | C     | C     | C     | C        | C     | C        |
| Dirt Bucket 1524 mm (60 inch)                  | C     | C     | C        | C     | C        | C     | C     | C     | C     | C        | C     | C        |
| Dirt Bucket 1676 mm (66 inch)                  | C     | C     | C        | C     | C        | C     | C     | C     | C     | C        | C     | C        |
| Dirt Bucket 1829 mm (72 inch)                  | C     | C     | C        | C     | C        | C     | C     | C     | C     | C        | C     | C        |
| Dirt Bucket 1981 mm (78 inch)                  | C     | C     | C        | C     | C        | C     | C     | C     | C     | C        | C     | C        |
| Light Material Bucket 1829 mm (72 inch)        | C     | C     | C        | C     | C        | C     | C     | C     | C     | C        | C     | C        |
| Light Material Bucket 1981 mm (78 inch)        | C     | C     | C        | C     | C        | C     | C     | C     | C     | C        | C     | C        |
| Light Material Bucket 2134 mm (84 inch)        | C     | C     | C        | C     | C        | C     | C     | C     | C     | C        | C     | C        |
| Light Material Bucket 2438 mm (96 inch)        | C     | C     | C        | C     | C        | C     | C     | C     | C     | C        | C     | C        |
| Utility Bucket 1524 mm (60 inch)               | C     | C     | C        | C     | C        | C     | C     | C     | C     | C        | C     | C        |
| Utility Bucket 1676 mm (66 inch)               | C     | C     | C        | C     | C        | C     | C     | C     | C     | C        | C     | C        |
| Utility Bucket 1829 mm (72 inch)               | C     | C     | C        | C     | C        | C     | C     | C     | C     | C        | C     | C        |
| A14B Auger                                     | C     | C     | C        | C     | C        | C     | C     | C     | C     | C        | C     | C        |
| A19B Auger                                     | C     | C     | C        | C     | C        | C     | C     | C     | C     | C        | C     | C        |
| A26B Auger                                     |       |       | C        |       | C        |       |       |       |       | C        |       | C        |
| BH27 Backhoe                                   | C     | C     | C        | C     | C        |       |       | C     | C     | C        | C     | C        |
| BH30 Backhoe                                   | C     | C     | C        | C     | C        |       |       | C     | C     | C        | C     | C        |
| BH30 w Backhoe                                 |       |       |          |       |          | C     | C     |       |       |          |       |          |
| BH150 Backhoe                                  | C     | C     | C        | C     | C        |       |       | C     | C     | C        | C     | C        |
| BH160 Backhoe                                  |       |       |          |       |          | C     | C     |       |       |          |       |          |

(continued)

Reference Information Section  
Caterpillar Approved Work Tools

(Table 47, contd)

| Cat Approved Work Tools for Skid Steer Loaders |       |       |             |       |             |       |       |       |       |             |       |             |
|--|-------|-------|-------------|-------|-------------|-------|-------|-------|-------|-------------|-------|-------------|
| Work Tool                                      | 216B3 | 226B3 | 226B3<br>HF | 242B3 | 242B3<br>HF | 236B3 | 252B3 | 247B3 | 257B3 | 257B3<br>HF | 259B3 | 259B3<br>HF |
| Single Bale Spear<br>39"                       | C     | C     | C           | C     | C           | C     | C     | C     | C     | C           | C     | C           |
| Double Bale Spear<br>39"                       | C     | C     | C           | C     | C           | C     | C     | C     | C     | C           | C     | C           |
| Single Bale Spear<br>49"                       | C     | C     | C           | C     | C           | C     | C     | C     | C     | C           | C     | C           |
| Double Bale Spear<br>49"                       | C     | C     | C           | C     | C           | C     | C     | C     | C     | C           | C     | C           |
| Angle Blade 1829<br>mm (72 inch)               | C     | C     | C           | C     | C           | C     | C     | C     | C     | C           | C     | C           |
| Angle Blade 2134<br>mm (84 inch)               | C     | C     | C           | C     | C           | C     | C     | C     | C     | C           | C     | C           |
| Dozer Blade 2007<br>mm (79 inch)               | C     | C     | C           | C     | C           | C     | C     | C     | C     | C           | C     | C           |
| Dozer Blade 2337<br>mm (92 inch)               | C     | C     | C           | C     | C           | C     | C     | C     | C     | C           | C     | C           |
| BA18 Angle Broom                               | C     | C     | C           | C     | C           | C     | C     | C     | C     | C           | C     | C           |
| BU115 Utility<br>Broom                         | C     | C     | C           | C     | C           | C     | C     | C     | C     | C           | C     | C           |
| BU118 Utility<br>Broom                         |       |       |             | C     | C           | C     | C     | C     | C     | C           | C     | C*          |
| BP15B Pickup<br>Broom                          | C     | C     | C           | C     | C           | C     | C     | C     | C     | C           | C     | C           |
| BP18B Pickup<br>Broom                          |       |       |             | C     | C           | C     | C     |       | C     | C           | C     | C*          |
| PC203 Cold Planer                              | C     | C     | C           | C     | C           | C     | C     | C     | C     | C           | C     | C           |
| PC204 Cold Planer                              |       | C     | C           | C     | C           | C     | C     | C     | C     | C           | C     | C           |
| PC205 Cold Planer                              |       |       | C           |       | C           |       |       |       |       | C           |       | C           |
| PC206 Cold Planer                              |       |       | C           |       | C           |       |       |       |       | C           |       | C           |
| Carriage and Fork<br>Tines                     | C     | C     | C           | C     | C           | C     | C     | C     | C     | C           | C     | C           |
| Utility Fork 1676<br>mm (66 inch)              | C     | C     | C           | C     | C           | C     | C     | C     | C     | C           | C     | C           |
| Utility Fork 1829<br>mm (72 inch)              | C     | C     | C           | C     | C           | C     | C     | C     | C     | C           | C     | C           |
| BRX118 Industrial<br>Brushcutter               |       |       |             |       |             |       |       |       | C^    | C^          | C^    | C^          |
| BRX318 Industrial<br>Brushcutter               |       |       |             |       |             |       |       |       | C^    |             |       | C^          |
| BRX418 Industrial<br>Brushcutter               |       |       |             |       |             |       |       |       |       |             |       |             |

(continued)

(Table 47, contd)

| Cat Approved Work Tools for Skid Steer Loaders    |       |       |             |       |             |       |       |       |       |             |       |             |
|---|-------|-------|-------------|-------|-------------|-------|-------|-------|-------|-------------|-------|-------------|
| Work Tool   | 216B3 | 226B3 | 226B3<br>HF | 242B3 | 242B3<br>HF | 236B3 | 252B3 | 247B3 | 257B3 | 257B3<br>HF | 259B3 | 259B3<br>HF |
| Industrial Grapple<br>Bucket 1524 mm<br>(60 inch) | C     | C     | C           | C     | C           | C     | C     | C     | C     | C           | C     | C           |
| Industrial Grapple<br>Bucket 1676 mm<br>(66 inch) | C     | C     | C           | C     | C           | C     | C     | C     | C     | C           | C     | C           |
| Industrial Grapple<br>Bucket 1829 mm<br>(72 inch) | C     | C     | C           | C     | C           | C     | C     | C     | C     | C           | C     | C           |
| Industrial Grapple<br>Bucket 1981 mm<br>(78 inch) | C     | C     | C           | C     | C           | C     | C     | C     | C     | C           | C     | C           |
| Industrial Grapple<br>Fork 1676 mm (66<br>inch)   | C     | C     | C           | C     | C           | C     | C     | C     | C     | C           | C     | C           |
| Industrial Grapple<br>Fork 1829 mm (72<br>inch)   | C     | C     | C           | C     | C           | C     | C     | C     | C     | C           | C     | C           |
| Industrial Grapple<br>Rake 1829 mm (72<br>inch)   | C     | C     | C           | C     | C           | C     | C     | C     | C     | C           | C     | C           |
| Industrial Grapple<br>Rake 2134 mm (84<br>inch)   | C     | C     | C           | C     | C           | C     | C     | C     | C     | C           | C     | C           |
| Utility Grapple<br>Bucket 1676 mm<br>(66 inch)    | C     | C     | C           | C     | C           | C     | C     | C     | C     | C           | C     | C           |
| Utility Grapple<br>Bucket 1829 mm<br>(72 inch)    | C     | C     | C           | C     | C           | C     | C     | C     | C     | C           | C     | C           |
| Utility Grapple Fork<br>1676 mm (66 inch)         | C     | C     | C           | C     | C           | C     | C     | C     | C     | C           | C     | C           |
| Utility Grapple Fork<br>1829 mm (72 inch)         | C     | C     | C           | C     | C           | C     | C     | C     | C     | C           | C     | C           |
| Material Handling<br>Arm                          | C     | C     | C           | C     | C           | C     | C     | C     | C     | C           | C     | C           |
| SR117 Snowblower                                  | C     | C     | C           | C     | C           | C     | C     | C     | C     | C           | C     | C           |
| SR118 Snowblower                                  | C     | C     | C           | C     | C           | C     | C     | C     | C     | C           | C     | C           |
| SR121 Snowblower                                  | C     | C     | C           | C     | C           | C     | C     | C     | C     | C           | C     | C           |
| SR318 Snowblower                                  |       |       | C           |       | C           |       |       |       |       | C           |       | C           |
| SR321 Snowblower                                  |       |       | C           |       | C           |       |       |       |       | C           |       | C           |
| LR15B Landscape<br>Rake                           | C     | C     | C           | C     | C           | C     | C     | C     | C     | C           | C     | C*          |

(continued)

Reference Information Section  
Caterpillar Approved Work Tools

(Table 47, contd)

| Cat Approved Work Tools for Skid Steer Loaders |       |       |             |       |             |       |       |       |       |             |       |             |
|--|-------|-------|-------------|-------|-------------|-------|-------|-------|-------|-------------|-------|-------------|
| Work Tool                                      | 216B3 | 226B3 | 226B3<br>HF | 242B3 | 242B3<br>HF | 236B3 | 252B3 | 247B3 | 257B3 | 257B3<br>HF | 259B3 | 259B3<br>HF |
| LR18B Landscape Rake                           |       |       |             |       |             | C     | C     | C     | C     | C           | C     | C*          |
| PR172 Power Rake                               | C     | C     | C           | C     | C           | C     | C     | C     | C     | C           | C     | C           |
| PR184 Power Rake                               | C     | C     | C           | C     | C           | C     | C     | C     | C     | C           | C     | C           |
| PR190 Power Rake                               | C     | C     | C           | C     | C           | C     | C     | C     | C     | C           | C     | C           |
| LT13B Landscape Tiller                         | C     | C     | C           | C     | C           | C     | C     | C     | C     | C           | C     | C           |
| LT18B Landscape Tiller                         |       |       |             |       |             | C     | C     | C     | C     | C           | C     | C           |
| SG16B Stump Grinder                            | C     | C     | C           | C     | C           | C     | C     | C     | C     | C           | C     | C           |
| SG18B Stump Grinder                            |       |       | C           |       | C           |       |       |       |       | C           |       | C           |
| T6B Trencher                                   | C     | C     | C           | C     | C           | C     | C     | C     | C     | C           | C     | C           |
| T9B Trencher                                   | C     | C     | C           | C     | C           | C     | C     | C     | C     | C           | C     | C           |
| T15B Trencher                                  |       |       | C           |       | C           |       |       |       |       | C           |       | C           |
| CV16B Vibratory Compactor                      | C     | C     | C           | C     | C           | C     | C     | C     | C     | C           | C     | C*          |
| CV18B Vibratory Compactor                      |       |       |             |       |             | C     | C     |       |       |             |       |             |
| SW45 Wheel Saw 3 inch                          |       |       | C           |       | C           |       |       |       |       | C           |       | C*          |
| SW45 Wheel Saw 6 inch                          |       |       | C           |       | C           |       |       |       |       | C           |       | C*          |
| SW45 Wheel Saw 8 inch                          |       |       | C           |       | C           |       |       |       |       | C           |       | C*          |
| SW60 Wheel Saw 8 inch                          |       |       |             |       |             |       |       |       |       |             |       |             |
| H55Ds Hammer                                   | C     | C     | C           | C     | C           | C     | C     | C     | C     | C           | C     | C           |
| H65Ds Hammer                                   | C     | C     | C           | C     | C           | C     | C     | C     | C     | C           | C     | C           |
| BR160 Brush Cutter                             | C     | C     | C           | C     | C           | C     | C     | C     | C     | C           | C     | C           |
| BR166 Brush Cutter                             | C     | C     | C           | C     | C           | C     | C     | C     | C     | C           | C     | C           |
| BR172 Brush Cutter                             | C     | C     | C           | C     | C           | C     | C     | C     | C     | C           | C     | C           |
| BR272 Brush Cutter                             |       |       | C           |       | C           |       |       |       |       | C           |       | C           |
| S305 Shear                                     |       |       |             | C     | C           | C     | C     | C     | C     | C           | C     | C           |
| Bale Grapple                                   | C     | C     | C           | C     | C           | C     | C     | C     | C     | C           | C     | C           |
| 84" Material Handling Bucket                   | C     | C     | C           | C     | C           | C     | C     | C     | C     | C           | C     | C           |

(continued)

(Table 47, contd)

| Cat Approved Work Tools for Skid Steer Loaders |       |       |          |       |          |       |       |       |       |          |       |          |
|--|-------|-------|----------|-------|----------|-------|-------|-------|-------|----------|-------|----------|
| Work Tool                                      | 216B3 | 226B3 | 226B3 HF | 242B3 | 242B3 HF | 236B3 | 252B3 | 247B3 | 257B3 | 257B3 HF | 259B3 | 259B3 HF |
| 96" Material Handling Bucket                   | C     | C     | C        | C     | C        | C     | C     | C     | C     | C        | C     | C        |
| 102" Material Handling Bucket                  | C     | C     | C        | C     | C        | C     | C     | C     | C     | C        | C     | C        |
| 8' Snow Pusher                                 | C     | C     | C        | C     | C        | C     | C     | C     | C     | C        | C     | C        |
| 10' Snow Pusher                                | C     | C     | C        | C     | C        | C     | C     | C     | C     | C        | C     | C        |
| 12' Snow Pusher                                | C     | C     | C        | C     | C        | C     | C     | C     | C     | C        | C     | C        |
| 8' Snow Pusher (Rubber Edge)                   | C     | C     | C        | C     | C        | C     | C     | C     | C     | C        | C     | C        |
| 10' Snow Pusher (Rubber Edge)                  | C     | C     | C        | C     | C        | C     | C     | C     | C     | C        | C     | C        |
| 12' Snow Pusher (Rubber Edge)                  | C     | C     | C        | C     | C        | C     | C     | C     | C     | C        | C     | C        |
| 6' Snow Blade                                  | C     | C     | C        | C     | C        | C     | C     | C     | C     | C        | C     | C        |
| 7' Snow Blade                                  | C     | C     | C        | C     | C        | C     | C     | C     | C     | C        | C     | C        |
| 8' Snow Blade                                  | C     | C     | C        | C     | C        | C     | C     | C     | C     | C        | C     | C        |
| 9' Snow Blade                                  | C     | C     | C        | C     | C        | C     | C     | C     | C     | C        | C     | C        |
| 10' Snow Blade                                 | C     | C     | C        | C     | C        | C     | C     | C     | C     | C        | C     | C        |
| BB121 Box Blade                                | C     | C     | C        | C     | C        | C     | C     | C     | C     | C        | C     | C        |
| BB124 Box Blade                                | C     | C     | C        | C     | C        | C     | C     | C     | C     | C        | C     | C        |

**C** – The work tool is compatible with this machine.

\* – This work tool has a lift restriction on this machine. Do not raise the lower pivot pin higher than 1 m (3 ft) above the ground.

**C^** - Compatible But Lift Restrictions Apply and Max Machine Counterweights Required.

Many of the work tools in the table have an Operation and Maintenance Manual. Refer to the Operation and Maintenance Manual that is provided with the work tool for the proper use of the work tool.

Consult your Cat dealer concerning specific work tools that are approved by Cat for this machine. This list was complete at the time of publication. There may be more work tools that have been approved since that time. Consult your Cat dealer for an updated list of approved work tools.

### INTENDED USE STATEMENT for the Material Handling Arm

This Work Tool has the intended functions of lifting and transporting suspended loads. Always select sufficiently sized lifting accessories. Always inspect the lifting accessories before use.

Do not use the work tool improperly.

Remove the work tool from the machine before you lift the host machine. Refer to Operation and Maintenance Manual, "Lifting and Tying Down the Machine" for details.

### INTENDED USE STATEMENT for the Multipurpose Bucket

This Work Tool has the intended functions of dozing, digging, loading, lifting, carrying, and moving material such as earth, crushed rock, or gravel.

Do not use the work tool improperly.

Remove the work tool from the machine before you lift the host machine. Refer to Operation and Maintenance Manual, "Lifting and Tying Down the Machine" for details.

### INTENDED USE STATEMENT for the Grapple Bucket

This Work Tool has the intended functions of digging, loading, lifting, carrying, and moving material such as earth, crushed rock, gravel, or debris.

Do not use the work tool improperly.

Remove the work tool from the machine before you lift the host machine. Refer to Operation and Maintenance Manual, "Lifting and Tying Down the Machine" for details.

## **INTENDED USE STATEMENT for the Grapple Rake**

This Work Tool has the intended functions of raking, loading, carrying, and moving bulky material. The material may be encountered in the following applications:

- Landscape cleanup
- Storm debris cleanup
- Demolition
- Industrial
- Construction

Do not use the work tool improperly.

- Do not pry with one rake tine. Use multiple rake tines to loosen material.
- Remove the work tool from the machine before you lift the host machine. Refer to Operation and Maintenance Manual, "Lifting and Tying Down the Machine" for details.
- Do not place the weight of the host machine on the grapples in the open position.

## **INTENDED USE STATEMENT for the Grapple Forks**

This Work Tool has the intended functions of loading, carrying, and moving bulky materials.

Do not use the work tool improperly.

Remove the work tool from the machine before you lift the host machine. Refer to Operation and Maintenance Manual, "Lifting and Tying Down the Machine" for details.

i07743978

## **Decommissioning and Disposal**

**SMCS Code:** 1000; 7000

When the product is removed from service, local regulations for the product decommissioning will vary. Disposal of the product will vary with local regulations.

Improperly disposing of waste can threaten the environment. Obey all local regulations for the decommissioning and disposal of materials.

Utilize appropriate personal protective equipment when decommissioning and disposing product.

Consult the nearest Cat dealer for additional information. Including information for component remanufacturing and recycling options.

# Index

## A

|   |         |
|---|---------|
| Access Doors and Covers .....                         | 133     |
| Engine Access Door .....                              | 133     |
| Additional Messages .....                             | 22, 24  |
| Lift Arm Down (2) .....                               | 23      |
| Product Link (If Equipped) .....                      | 24      |
| Work Tool Detach (1) .....                            | 23      |
| After Roothing the Machine .....                      | 123     |
| Air Cleaner Dust Valve - Clean/Inspect .....          | 157     |
| Air Conditioner Condenser - Clean (If Equipped) ..... | 157     |
| Alert Indicators .....                                | 92      |
| Alternate Exit .....                                  | 75      |
| Primary Exit .....                                    | 75      |
| Secondary Exit .....                                  | 75      |
| Axle Bearings - Lubricate .....                       | 157–158 |

## B

|  |        |
|--|--------|
| Backup Alarm - Test .....                        | 158    |
| Battery or Battery Cable - Inspect/Replace ..... | 158    |
| Battery - Recycle .....                          | 158    |
| Before Operation .....                           | 34, 73 |
| Before Roothing the Machine .....                | 118    |
| Brackets (Rear Lights) .....                     | 118    |
| First Aid Kit .....                              | 118    |
| Headlights .....                                 | 118    |
| Hydraulic Shutoff .....                          | 118    |
| Lift Arm .....                                   | 118    |
| Mirrors .....                                    | 120    |
| Portable Warning Light .....                     | 120    |
| Prepare the Work Tool .....                      | 121    |
| Rotating Beacon Light .....                      | 120    |
| Slow Moving Vehicle Sign .....                   | 120    |
| Tires .....                                      | 120    |
| Traffic Regulations .....                        | 120    |
| Work Lights .....                                | 120    |
| Before Starting Engine .....                     | 32     |
| Belts - Inspect/Adjust/Replace .....             | 159    |
| Air Conditioner (if equipped) .....              | 160    |
| Belts .....                                      | 160    |
| Finish .....                                     | 161    |
| Blade Frame - Adjust .....                       | 162    |
| Height Adjustment .....                          | 162    |
| Trunnion Joint .....                             | 162    |
| Bogie and Idler - Inspect/Replace .....          | 163    |
| Bogie wheels .....                               | 165    |
| Idler wheels .....                               | 164    |

|  |     |
|--|-----|
| Inspect .....                                | 163 |
| Loosen the Track .....                       | 164 |
| Bucket Cutting Edges - Inspect/Replace ..... | 165 |
| Bucket Tips - Inspect/Replace .....          | 165 |
| Burn Prevention .....                        | 27  |
| Batteries .....                              | 28  |
| Coolant .....                                | 27  |
| Oils .....                                   | 28  |

## C

|  |     |
|--|-----|
| Cab Air Filter - Clean/Replace (If Equipped) .....         | 166 |
| Fresh Air Filter .....                                     | 166 |
| Recirculation Filter .....                                 | 166 |
| Cab Tilting .....  | 133 |
| Tilting the Cab Downward .....                             | 134 |
| Tilting the Cab Upward .....                               | 133 |
| Capacities (Refill) .....                                  | 145 |
| Caterpillar Approved Work Tools .....                      | 223 |
| INTENDED USE STATEMENT for the Grapple Bucket .....        | 229 |
| INTENDED USE STATEMENT for the Grapple Forks .....         | 230 |
| INTENDED USE STATEMENT for the Grapple Rake .....          | 230 |
| INTENDED USE STATEMENT for the Material Handling Arm ..... | 229 |
| INTENDED USE STATEMENT for the Multipurpose Bucket .....   | 229 |
| Cooling System Coolant (ELC) - Change .....                | 166 |
| Cooling System Coolant Extender (ELC) - Add .....          | 168 |
| Cooling System Coolant Sample (Level 1) - Obtain .....     | 169 |
| Cooling System Coolant Sample (Level 2) - Obtain .....     | 170 |
| Cooling System Level - Check .....                         | 170 |
| Cooling System Water Temperature Regulator - Replace ..... | 171 |
| Crushing Prevention and Cutting Prevention .....           | 27  |

## D

|                                     |       |
|-------------------------------------|-------|
| Daily Inspection .....              | 73    |
| Declaration of Conformity .....     | 65–72 |
| Decommissioning and Disposal .....  | 230   |
| Demolition .....                    | 36    |
| Drive Chain Case Oil - Change ..... | 172   |

|   |          |  |     |
|---|----------|--|-----|
| Drive Chain Case Breathers.....                             | 173      | Operation.....   | 4   |
| Drive Chain Case Oil - Check.....                           | 173      | Product Identification Number.....   | 5   |
| Drive Chain Tension - Check/Adjust.....                     | 174      | Safety.....  | 4   |
| <b>E</b>  |          | Fuel Injection Timing - Check.....   | 188 |
| Electrical Storm Injury Prevention.....                     | 32       | Fuel System Filter (In-Line) - Replace.....  | 188 |
| Emissions Certification Film.....                           | 62       | Fuel System Primary Filter (Water<br>Separator) - Drain.....   | 189 |
| Engine Air Filter Primary Element - Clean/<br>Replace.....  | 176      | Fuel System Primary Filter (Water<br>Separator) Element - Replace.....   | 190 |
| Clean.....  | 176      | Fuel System Priming Pump - Operate.....  | 191 |
| Replace.....  | 177      | C2.2 Engine.....   | 191 |
| Engine Air Filter Secondary Element -<br>Replace.....       | 178      | C3.4 Engine.....   | 191 |
| Engine Compartment - Inspect/Clean.....                     | 179      | Fuel Tank Cap - Clean.....   | 192 |
| Air Conditioning Condenser.....                             | 179      | Fuel Tank Water and Sediment - Drain.....  | 192 |
| Engine Crankcase Breather - Clean.....                      | 179      | Fuses - Replace.....   | 193 |
| Engine Oil and Filter - Change.....                         | 182, 184 | Fuse panel behind cab.....   | 195 |
| Engine Oil Level - Check.....                               | 181      | Fuses.....   | 193 |
| Engine Oil Sample - Obtain.....                             | 182      | Main Fuse.....   | 195 |
| Engine Starting.....  | 33, 97   | <b>G</b>   |     |
| Engine Starting (Alternate Methods).....                    | 131      | General Hazard Information.....  | 24  |
| Engine Starting with Jump Start Cables.....                 | 131      | Containing Fluid Spillage.....   | 26  |
| Engine Valve Lash - Check.....                              | 186      | Dispose of Waste Properly.....   | 27  |
| Equipment Lowering Control Valve -<br>Check.....            | 186      | Fluid Penetration.....   | 25  |
| Equipment Lowering with Engine Stopped....                  | 38, 114  | Inhalation.....  | 26  |
| Alternate Lowering the Equipment.....                       | 115      | Pressurized Air and Water.....   | 25  |
| Lowering the Equipment with the Accumulator<br>Charged..... | 114      | Trapped Pressure.....  | 25  |
| <b>F</b>  |          | General Information.....   | 43  |
| Final Drive Oil - Change.....                               | 186      | Guards.....  | 41  |
| Final Drive Oil - Change Procedure.....                     | 187      | Guards (Operator Protection)   |     |
| Final Drive Oil Level - Check.....                          | 187      | Other Guards (If Equipped).....  | 42  |
| Fire Extinguisher Location.....                             | 32       | Roll over Protective Structure (ROPS), Falling<br>Object Protective Structure (FOPS) or Tip<br>Over Protection Structure (TOPS)..... | 41  |
| Fire Prevention and Explosion Prevention.....               | 28       | <b>H</b>   |     |
| Battery and Battery Cables.....                             | 29       | Headlights - Adjust.....   | 196 |
| Ether.....  | 31       | Hydraulic System Oil - Change.....   | 196 |
| Fire Extinguisher.....                                      | 31       | Procedure for Changing the Hydraulic<br>Oil.....   | 197 |
| General.....  | 28       | Selection of the Oil Change Interval.....  | 196 |
| Lines, Tubes, and Hoses.....                                | 30       | Hydraulic System Oil Filter - Replace.....   | 199 |
| Wiring.....   | 30       | Hydraulic System Oil Level - Check.....  | 200 |
| Fire Safety.....  | 31       | Hydraulic System Oil Sample - Obtain.....  | 200 |
| Foreword.....   | 4        | <b>I</b>   |     |
| California Proposition 65 Warning.....                      | 4        | Identification Information.....  | 60  |
| Certified Engine Maintenance.....                           | 5        | Important Safety Information.....  | 2   |
| Literature Information.....                                 | 4        |  |     |
| Machine Capacity.....                                       | 5        |  |     |
| Maintenance.....  | 4        |  |     |

|   |          |
|---|----------|
| <b>L</b>  |          |
| Leaving the Machine .....   | 115      |
| Lift Arm and Cylinder Linkage - Lubricate .....   | 200      |
| Lifting and Tying Down the Machine .....  | 125      |
| Lifting the Grapple Rake .....  | 127      |
| Lifting the Machine.....  | 125      |
| Tying Down the Machine .....  | 127      |
| Loader Lift Arm Brace Operation .....   | 135, 137 |
| Disengage the Lift Arm Brace.....   | 138      |
| Disengage the Lift Arm Brace (Extended Lift) .....  | 137      |
| Disengage the Lift Arm Brace (Radial Lift) .....  | 136      |
| Engage the Lift Arm Brace.....  | 137      |
| Engage the Lift Arm Brace (Extended Lift) .....   | 136      |
| Engage the Lift Arm Brace (Radial Lift) .....   | 135      |
| Lower Machine Frame - Clean .....   | 201      |
| Lubricant Viscosities .....   | 140      |
| Biodiesel .....   | 145      |
| Coolant Information .....   | 145      |
| Diesel Fuel Recommendations .....   | 144      |
| Fuel Additives .....  | 145      |
| General Information for Lubricants .....  | 140      |
| Lubricant Viscosities for Ambient Temperatures .....                                      | 141      |
| Selecting the Viscosity.....  | 140      |
| Special Lubricants .....  | 144      |
| Lubricant Viscosities and Refill Capacities ...   | 140      |
| <b>M</b>  |          |
| Machine Operation .....   | 75       |
| Machine Security System.....  | 96       |
| Basic Operation .....   | 96       |
| Machine Security System (If Equipped) .....   | 96       |
| Security Management.....  | 96       |
| Machine Storage and Specified Storage Period .....  | 116      |
| Machine Storage .....   | 116      |
| Specified Storage Period.....   | 116      |
| Maintenance Access .....  | 133      |
| Maintenance Interval Schedule.....  | 154      |
| Every 10 Service Hours or Daily.....  | 154      |
| Every 1000 Service Hours.....   | 155      |
| Every 1000 Service Hours or 1 Year .....  | 155      |
| Every 1000 Service Hours or 6 Months.....   | 155      |
| Every 12 000 Service Hours or 6 Years.....  | 156      |
| Every 2000 Service Hours.....   | 155      |
| Every 2000 Service Hours or 1 Year .....  | 155      |
| Every 250 Service Hours.....  | 155      |
| Every 250 Service Hours or Monthly .....  | 155      |
| Every 3 Years.....  | 156      |
| Every 3 Years After Date of Installation or Every 5 Years After Date of Manufacture ..... | 156      |
| Every 3000 Service Hours or 2 Years .....   | 156      |
| Every 500 Service Hours.....  | 155      |
| Every 500 Service Hours or 1 Year .....   | 155      |
| Every 500 Service Hours or 3 Months.....  | 155      |
| Every 500 Service Hours or 6 Months.....  | 155      |
| Every 6000 Service Hours or 3 Years .....   | 156      |
| Every Year .....  | 156      |
| Initial 250 Service Hours.....  | 155      |
| When Required.....  | 154      |
| Maintenance Section.....  | 133      |
| Maintenance Support .....   | 147      |
| Material Handling Arm Operation.....  | 105      |
| One Person Operation.....   | 107      |
| Two Person Operation.....   | 106      |
| Mounting and Dismounting .....  | 73       |
| Alternate Exit .....  | 73       |
| Machine Access System Specifications.....   | 73       |
| <b>O</b>  |          |
| Oil Filter - Inspect .....  | 201      |
| Inspect a Used Filter for Debris .....  | 201      |
| Operation.....  | 34, 98   |
| Limiting Conditions and Criteria .....  | 34       |
| Operation Information .....   | 98       |
| Counterrotate turn .....  | 100      |
| General Information.....  | 98       |
| Operating on a Slope.....   | 98       |
| Operating on a Transition .....   | 99       |
| Operation Section.....  | 73       |
| Operator Controls.....  | 77       |
| Accelerator Control (23) .....  | 84       |
| Air Conditioner Control (20).....   | 84       |
| Automatic Level Control (2).....  | 80       |
| Auxiliary Electrical Control (3) .....  | 80       |
| Auxiliary Hydraulic Pressure Release (1)....  | 80       |
| Auxiliary Work Tool Controls.....   | 88       |
| Backward .....  | 87       |
| Cab Dome Light (8) .....  | 82       |
| Continuous Flow Control .....   | 90       |
| Dedicated Dual Direction Control Kit.....   | 90       |
| Dump .....  | 87, 92   |
| Engine Start Switch (15).....   | 83       |
| Engine Start Switch (15A) (Only for prefixes PWK and DXZ) .....                           | 83       |
| Fan Speed Control (22).....   | 84       |
| Float.....  | 87, 92   |

|  |         |  |       |
|--|---------|--|-------|
| Forward.....   | 87, 92  | <b>Q</b>   |       |
| Front Work Lights (13).....  | 82      | Quick Coupler - Clean/Inspect .....  | 202   |
| Fuel Level Gauge (11).....   | 82      | <b>R</b>   |       |
| Governor Control (19).....   | 83      | Radiator Core - Clean .....  | 202   |
| Hazard Flashers (6).....   | 81      | Radiator Tilting .....   | 138   |
| Horn .....   | 87      | Tilting the Radiator Guard.....  | 139   |
| Hydraulic Lockout and Interlock Override<br>(7).....                             | 81      | Rated Load .....   | 43    |
| Interlock Control (24).....  | 84      | Bucket Rated Load .....  | 43    |
| Joystick and Auxiliary Hydraulic Controls ...                                    | 85      | Rated Load with a Material Handling Arm... ..  | 54    |
| Joystick and Auxiliary Hydraulic Controls<br>(Only for prefixes PWK and DXZ..... | 87      | Rated Loads for Forks .....  | 51    |
| Joystick Control (17).....   | 83      | Reference Information Section .....  | 222   |
| Joystick Control (18).....   | 83      | Reference Material .....   | 222   |
| Left Turn.....   | 87, 92  | Additional Reference Material .....  | 223   |
| Lower .....  | 87, 92  | Cooling System.....  | 222   |
| Parking Brake Control (9).....   | 82      | Grease .....   | 222   |
| Raise.....   | 87, 92  | Hydraulic Oil .....  | 222   |
| Rear Work Lights (12).....   | 82      | Miscellaneous Publications .....   | 222   |
| Reverse .....  | 92      | Oil.....   | 222   |
| Right Turn .....   | 87, 92  | Operation and Maintenance Manuals .....  | 222   |
| Roading Lights (5).....  | 81      | Product Link.....  | 223   |
| Roading Lights (Only for prefixes PWK and<br>DXZ).....                           | 85      | ROPS/FOPS Structure .....  | 223   |
| Seat.....  | 84      | S·O·S Information.....   | 223   |
| Service Hour Meter (10).....   | 82      | Safety Information .....   | 223   |
| Service Hour Meter (10A) (Only for prefixes<br>PWK and DXZ) .....                | 82      | Specifications Manuals.....  | 223   |
| Temperature Control (21) .....   | 84      | Tools.....   | 223   |
| Tilt Back .....  | 87, 92  | Reference Materials .....  | 222   |
| Turn Signals (14) .....  | 83      | Refrigerant Dryer - Replace (If Equipped) ....   | 203   |
| Two Speed Control .....  | 87      | Restricted Visibility .....  | 32    |
| Window Wiper and Window Washer (16)....  | 83      | Roading the Machine .....  | 124   |
| Work Tool Coupler Control (4).....   | 81      | Rollover Protective Structure (ROPS) and<br>Falling Object Protective Structure<br>(FOPS) - Inspect..... | 204   |
| <b>P</b>   |         | <b>S</b>   |       |
| Pallet Forks Operation .....   | 109     | S·O·S Information .....  | 146   |
| Pallet Fork Tines Installation .....   | 110     | Safety Messages.....   | 6, 14 |
| Parking .....  | 37, 113 | Accumulator (13) .....   | 21    |
| Plate Locations and Film Locations .....   | 60      | Accumulator (14) .....   | 22    |
| CE Plate.....  | 61      | Aerosol Starting Aid (12) .....  | 21    |
| Eurasian Economic Union .....  | 62      | Batteries (5).....   | 18    |
| Manufacturer Information .....   | 62      | Brace for the Loader Lift Arms (10) .....  | 20    |
| Product Identification Number (PIN).....   | 60      | Cab Support (3) .....  | 17    |
| Product Information Section.....   | 43      | Crush Hazard (4) .....   | 18    |
| Product Link .....   | 94      | Do Not Operate (1) .....   | 17    |
| Data Broadcasts .....  | 95      | Never Permit Riders (7).....   | 19    |
| Operation in a Blast Site for Product Link<br>Radios.....                        | 95      | Pressurized System (9).....  | 20    |
|  |         | Rollover Protective Structure/Falling Object<br>Protective Structure (2).....                            | 17    |

|  |     |  |     |
|--|-----|--|-----|
| Seat Belt (8).....                           | 20  | Machine Data.....                          | 58  |
| Stay Inside Operator Station (6).....        | 19  | Sprocket - Inspect .....                   | 205 |
| Work Tool Coupler (11).....                  | 21  | Sprocket Inspection for 247B3 and          |     |
| Safety Messages (Work Tools)                 |     | 257B3.....                                 | 205 |
| Angle Blade (5).....                         | 9   | Sprocket Inspection for 259B3 .....        | 207 |
| Dozer Blade (10).....                        | 12  | Sprocket Retaining Nuts - Check .....      | 208 |
| Dozer Blade (11).....                        | 12  | Sprocket Sleeve - Inspect .....            | 208 |
| Dozer Blade (12).....                        | 13  | Stopping the Engine .....                  | 113 |
| Dozer Blade (9).....                         | 11  | Stopping the Engine if an Electrical       |     |
| Grapple Rake (13).....                       | 13  | Malfunction Occurs.....                    | 113 |
| Industrial Grapple Bucket (1).....           | 8   | Inside Cab.....                            | 113 |
| Industrial Grapple Fork (3).....             | 8   | Outside Cab.....                           | 114 |
| Industrial Grapple Fork (4).....             | 9   |  |     |
| Utility Fork (2) .....                       | 8   | <b>T</b>                                   |     |
| Utility Grapple Bucket (8).....              | 11  | Table of Contents .....                    | 3   |
| Utility Grapple Fork (6).....                | 10  | Tilt Cylinder Bearings and Bucket Linkage  |     |
| Utility Grapple Fork (7).....                | 10  | Bearings - Lubricate .....                 | 209 |
| Safety Section .....                         | 6   | Tire Inflation - Check .....               | 209 |
| Seat Belt.....                               | 75  | Tire Inflation with Air .....              | 210 |
| Extension of the Seat Belt .....             | 77  | Tire Inflation with Nitrogen.....          | 210 |
| Seat Belt Adjustment for Non-Retractable     |     | Towing Information .....                   | 130 |
| Seat Belts.....                              | 76  | Towing the Machine.....                    | 130 |
| Seat Belt Adjustment for Retractable Seat    |     | Retrieval of Machine.....                  | 130 |
| Belts .....                                  | 77  | Track - Inspect/Adjust (CTL) .....         | 214 |
| Seat Belt - Inspect.....                     | 204 | Detension the track.....                   | 216 |
| Seat Belt - Replace .....                    | 205 | Inspect .....                              | 215 |
| Service Interval Chart.....                  | 147 | Track Adjustment.....                      | 215 |
| 216B3, 226B3, and 236B3 .....                | 148 | Track (Rubber) - Inspect/Adjust .....      | 211 |
| 242B3, and 252B3.....                        | 148 | Track Adjustment.....                      | 211 |
| 247B3.....                                   | 149 | Track (Rubber) - Remove/Replace (CTL)..... | 213 |
| 257B3, and 259B3 .....                       | 150 | Installing the Track.....                  | 214 |
| Service Intervals .....                      | 151 | Removing the Track.....                    | 213 |
| Shipping the Machine.....                    | 117 | Track (Rubber) - Remove/Replace (MTL) .... | 212 |
| Loading the Machine .....                    | 117 | Installing the Track.....                  | 213 |
| Unloading the Machine.....                   | 118 | Removing the Track.....                    | 212 |
| Slope Operation .....                        | 37  | Track Roller and Idler - Inspect/Replace   |     |
| Sound Information and Vibration              |     | (CTL - Steel Track) .....                  | 216 |
| Information.....                             | 38  | Inspect .....                              | 216 |
| Sound Level Information.....                 | 38  | Transportation Information .....           | 117 |
| Sound Level Information for Machines in      |     |  |     |
| Eurasian Economic Union Countries.....       | 38  | <b>V</b>                                   |     |
| Sound Level Information for Machines in      |     | Visibility Information .....               | 33  |
| European Union Countries and in Countries    |     |  |     |
| that Adopt the "EU Directives" .....         | 38  | <b>W</b>                                   |     |
| Sources.....                                 | 41  | Welding on Machines and Engines with       |     |
| "The European Union Physical Agents          |     | Electronic Controls .....                  | 152 |
| (Vibration) Directive 2002/44/EC" .....      | 39  | Wheel Nuts - Tighten.....                  | 216 |
| Specifications .....                         | 57  | Window Washer Reservoir - Fill (If         |     |
| Application/Configuration Restrictions ..... | 58  | Equipped) .....                            | 217 |
| Expected Life .....                          | 57  |  |     |
| Intended Use .....                           | 57  |  |     |

|  |     |
|--|-----|
| Window Wiper - Inspect/Replace (If Equipped) .....     | 217 |
| Windows - Clean .....                                  | 217 |
| Polycarbonate Front Door .....                         | 218 |
| Work Tool - Lubricate .....                            | 218 |
| Angle Blade .....                                      | 219 |
| Dozer Blade .....                                      | 220 |
| Grapple Rake.....                                      | 219 |
| Industrial Grapple Tools.....                          | 219 |
| Multipurpose Bucket.....                               | 218 |
| Utility Grapple Tools.....                             | 218 |
| Work Tool Coupler Operation .....                      | 100 |
| Attaching the Work Tool.....                           | 100 |
| Releasing the Auxiliary Hydraulic System Pressure..... | 104 |
| Removing the Work Tool .....                           | 103 |
| Work Tool Guard and Reflector - Inspect/Replace .....  | 220 |
| Work Tool Mounting Bracket - Inspect .....             | 221 |
| Work Tool Operation.....                               | 110 |
| Complex Hydromechanical Work Tools .....               | 112 |
| Simple Hydromechanical Work Tools.....                 | 111 |
| Work Tools.....  | 36  |

# Product and Dealer Information

Note: For product identification plate locations, see the section "Product Identification Information" in the Operation and Maintenance Manual.

Delivery Date: \_\_\_\_\_

## Product Information

Model: \_\_\_\_\_

Product Identification Number: \_\_\_\_\_

Engine Serial Number: \_\_\_\_\_

Transmission Serial Number: \_\_\_\_\_

Generator Serial Number: \_\_\_\_\_

Attachment Serial Numbers: \_\_\_\_\_

Attachment Information: \_\_\_\_\_

Customer Equipment Number: \_\_\_\_\_

Dealer Equipment Number: \_\_\_\_\_

## Dealer Information

Name: \_\_\_\_\_ Branch: \_\_\_\_\_

Address: \_\_\_\_\_

\_\_\_\_\_

\_\_\_\_\_

Dealer Contact

Phone Number

Hours

Sales: \_\_\_\_\_

Parts: \_\_\_\_\_

Service: \_\_\_\_\_



SEBU8495  
©2019 Caterpillar  
All Rights Reserved

CAT, CATERPILLAR, their respective logos, "Caterpillar Yellow", and the POWER EDGE trade dress as well as corporate and product identity used herein, are trademarks of Caterpillar and may not be used without permission.