

DECLARATION OF CONFORMITY

as defined by machinery directive 98/37/EG

Herewith we declare that

Tandem vibration roller AMMANN AV 26E – TFAAV26EY20003017

complies with the following applying to it:

- Machinery directive 98/37/EG
- Noise standard 2000/14/EG
- EMC-Norm 89/336/EG (resp. 92/031/EG and 93/68/EG)

Applied harmonised standards in particular:

- EN 500-1: Mobile road construction machinery - Safety - Part 1: Common requirements
- EN 500-4: Mobile road construction machinery - Safety - Part 4: Specific requirements for compaction machines

Test reports: Inspections office: TÜV Austria Office-No.: 0408
Test reports-No.: 01-41-704-1277-0317/3 Date: Dec. 01
Measured noise level: 102 dBA
Guaranteed noise level: 106 dBA

Langenthal, 26.03.2002

AMMANN Verdichtung AG
Langenthal/Switzerland

Manual (EN)



AV23-2, AV26-2, AV32-2, AV33-2, AV40-2
AV23-2K, AV26-2K, AV32-2K, AV40-2K
Yanmar

Serial No. 22'500-

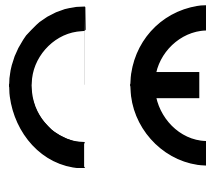

Declaration of Conformity

This is to certify that the machine/group of machines indicated below conform(s) to the relevant basic safety and health requirements of the relevant EC directives in terms of their conception and design and in the form marketed by us.

This declaration shall cease to be valid in the event of any change made to the machine/group of machines after handover to the trader/user if such changes are not agreed with us.

Name of machine or group of machines: AV23-2, AV26-2, AV32-2, AV33-2, AV40-2, AV23-2K, AV26-2K, AV32-2K, AV40-2K

Model: Tandem roller & combined roller

Relevant EC directives: EC - Machinery Directive 2006/42/EC with amendment 2006/42/EC
EC - Electromagnetic Compatibility Directive 89/336/EC with amendments 2004/108/EC
EC - Emission Directive 97/68/EC
EC - Noise Directive 2000/14/EC with amendment 2005/88/EC

Applicable harmonized norms, particularly: EN 500-1, EN 500-4, EN 982, EN ISO 14121-1, ISO 12100-1, ISO 12100-2, EN ISO 13850

Issuing testing office for noise tests: TÜV Austria (Austrian technical inspectorate)
Testing body no. 0408
Test report number: 09-UWC/WELS-EX-291
Date: 11.10.2009
Recorded sound power level: 102 dB(A)
Guaranteed sound power level: 106 dB(A)

Place, Date: Langenthal, November 2009

Company: Ammann Schweiz AG
Address: Eisenbahnstrasse 25
4901 Langenthal, Switzerland

**Authorized officer/
Technical inspector:**

Name of undersigned:  W. Traller
Position of undersigned: Customer Service Manager

 Ch. Anliker
Head of technology

Preface

Congratulations on your purchase of an Ammann compaction roller.

This quality of this compaction device is characterized by simple operation and maintenance and is the product of many years of Ammann experience in the field of road roller engineering.

Because the content of the deliverable depends on the order, the features of your roller may differ in some descriptions and pictures.

In order to avoid faults due to improper operation and maintenance we request that you read this operating manual with great care and keep it for future reference.

With kind regards,

AMMANN

Ammann Schweiz AG
Eisenbahnstrasse 25
CH-4901 Langenthal

www.ammann-group.ch

☎ 0041 (0)62 916 61 61

FAX 0041 (0)62 916 68 04

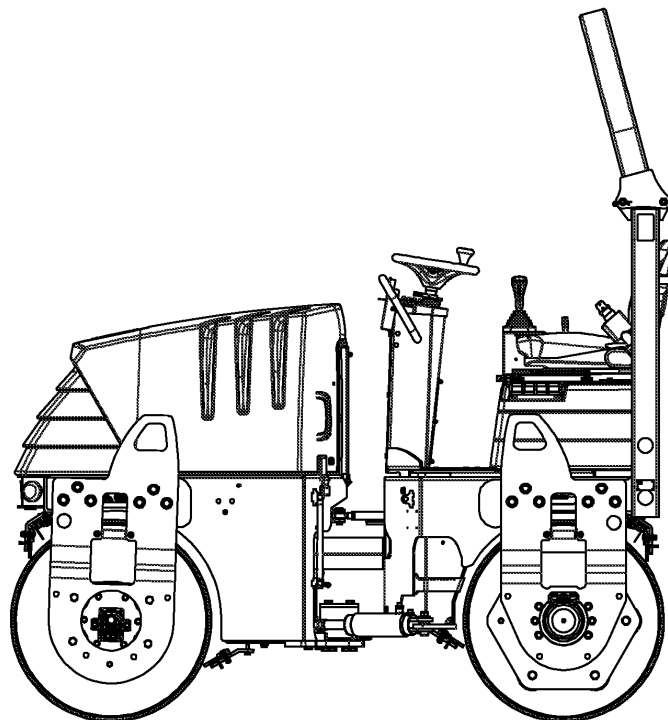

300048495007

Contents

Preface	1
Contents	2
1 Structure of the manual	5
Structure of the manual	6
Pictograms	8
2 Identification	9
Identification	10
Identification plate	11
Scope of delivery	12
3 Safety	13
General working safety	14
Roller operation	16
Roll-over bar (ROPS)	19
Safety markings on the machine	20
Noise levels	23
Safety (maintenance)	24
Vibration hazard	28
Notes	29
Notes	30
4 Transport / Commissioning	31
Transport	32
Center of gravity	34
Joint protection	35
Commissioning	36
Notes	38
5 Overview	39
Intended use	40
Inappropriate use	41
Component overview	42
Dashboard (switches)	44
Dashboard (control lamps)	45
Operation check	46
Notes	49
Notes	50
6 Operating	51
Driver's seat	52
Roll-over bar (ROPS)	54
Starting the engine	56
Driving and braking	59
Working speed	61
Turning off the engine	62
Emergency stop	63

Contents

Parking brake	64
Sprinkling.....	65
Simple/double vibration	67
Notes	68
7 Options	69
Edge cutter	70
Revolving warning light	73
Roof.....	76
Driver's platform cover	78
Reverse alarm	79
Battery cut-off switch	80
Traction aid (flow divider)	82
Lighting	83
Interval sprinkler.....	84
Delayed seat contact.....	85
Anti-adhesive.....	86
Anti-adhesive designations	87
1-point lifting eye	88
Automatic vibration.....	89
Seat heating	91
ROPS2D.....	92
Notes	94
8 Maintenance	95
Important notes	96
Roller maintenance	97
Maintenance check sheet.....	100
Yanmar engine maintenance	102
Towing, releasing brakes	104
Opening the hood.....	108
Engine compartment inspection summary	110
Inspect – engine oil level, coolant level.....	111
Inspect – fuel level, hydraulic oil level	112
Checks – sprinkler system, scraper	113
Checks – tire pressure	114
Checks – air filter cartridges.....	115
Checks – Seat contact and emergency stop.....	116
Inspect – brakes (brake test).....	117
Lubricate steering cylinder bearing	119
Removing the front water tank	120
Removing the rear water tank	122
Lubricant table.....	123
Consumables, tightening torques.....	125
Replace engine oil.....	126
Cleaning	127

Contents

Notes	128
9 Tips	129
Replacing the front bulbs.....	130
Replacing the rear bulbs	133
Engine compartment fuses.....	134
Steering column fuses.....	135
Battery	136
Notes	137
Notes	138
10 Storage	139
Storage	140
Draining the water tank	142
Winterization, emptying the water tank	143
Draining diesel.....	145
Notes	146
11 Hydraulics diagram	147
AV23 - AV40 hydraulics diagram	148
AV23 - AV40 hydraulics diagram legend	149
Hydraulic diagram AV23K-AV40K.....	150
AV23K - AV40K hydraulics diagram legend.....	151
AV23K - AV40K Edge Cutter hydraulics diagram	152
AV23K - AV40K Edge Cutter hydraulics diagram legend	153
Notes	154
12 Wiring diagram.....	155
Wiring diagram (multifunction display)	156
Wiring diagram (engine start/stop)	157
Wiring diagram (emergency stop / oil cooler, diesel pump)	158
Wiring diagram (sprinkler)	159
Wiring diagram (vibration, ROPS2D)	160
Wiring diagram (horn, indicators)	161
Wiring diagram (lights)	162
Wiring diagram (options)	163
Wiring diagram (operating lever control)	164
Wiring diagram (delayed seat switch)	165
Wiring diagram key.....	166
13 Specifications	171
Dimensions.....	172
Specifications AV2-2	173
Specifications AV2-2K.....	174
Specifications AV2-2 sidefree	175
Notes	176

1 Structure of the manual

Structure of the manual

The following explanations are designed to familiarize you with the roller and to provide support for handling and maintenance.

Structure of the manual

These operating instructions contains the following sections:

- Table of contents
- Structure of the manual
- Identification
- Safety
- Transport/commissioning
- Overview
- Operating
- Options
- Maintenance
- Tips
- Storage
- Hydraulic layout
- Wiring diagram
- Specifications

It is essential that you read the Safety section carefully before commissioning - and carrying out maintenance work.

Observing the Safety section in particular increases the reliability of the machine in operation and its service life. This reduces repair costs and down time.

Spare parts

Spare parts must meet Ammann technical specifications. These requirement are fulfilled if only original Ammann spare parts are used.

Storage and completeness of the manual

- This manual is an integral part of the roller and must be kept available for the user of the roller to consult.
- Never remove sections from this manual. Missing pages - specifically the Safety section - must be replaced immediately if lost.
- The manual must be retained for the lifetime of the roller and must be passed on to every subsequent owner or user of the machine.

Revision service

This documentation is not subject to the revision service of Ammann Schweiz AG. Changes may be made to this documentation without notification.

Structure of the manual

Roller designations in the descriptions

In order to facilitate orientation, we will tell you where to find the appropriate parts in the various sections.

The descriptions are based on the principle:
The roller is viewed from the rear looking forward.

Example, unlocking the hood:

The hood **lock** is located on the left-hand side...

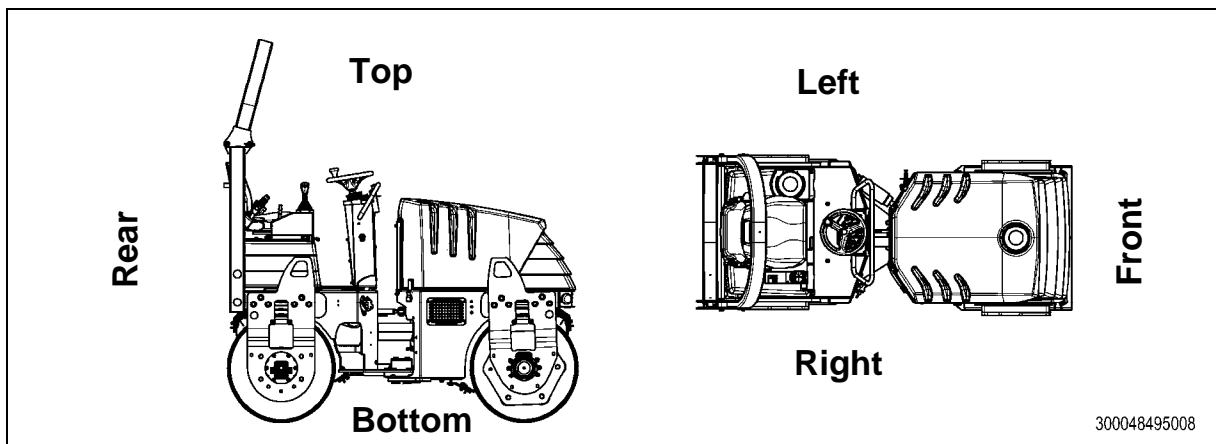

Pictograms

Important points are indicated as follows:



Indicates an immediate impending danger.
Failure to avert such dangers will lead to death or extremely serious injuries.



Indicates a potentially harmful situation.
Failure to avert this situation may damage the product or objects in its vicinity.



Indicates application tips and other particularly useful information. This is not a sign of a dangerous or harmful situation.

2 Identification

Identification

This manual applies to the following machines.

The data given below serve to identify the models. Please refer to the 'Specifications' section for details on the various machines.

Roller with roller drum

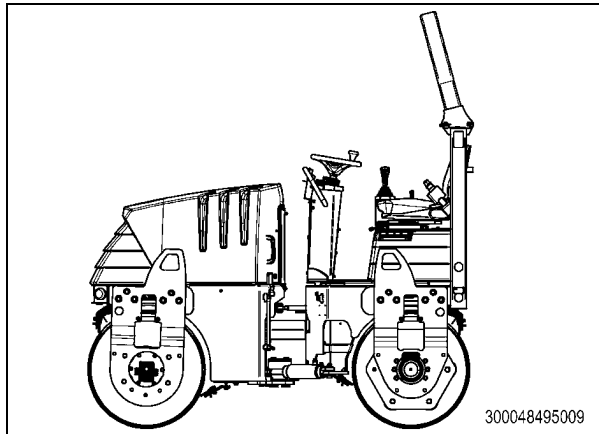

Model	Width	Weight
AV23-2	1121 mm	2410 kg
AV23-2 S*	1140 mm	2650 kg
AV26-2	1326 mm	2660 kg
AV26-2 S*	1340 mm	2850 kg
AV32-2	1310 mm	3160 kg
AV33-2	1412 mm	3450 kg
AV40-2	1412 mm	3800 kg

Roller with pneumatic wheel (combined roller)

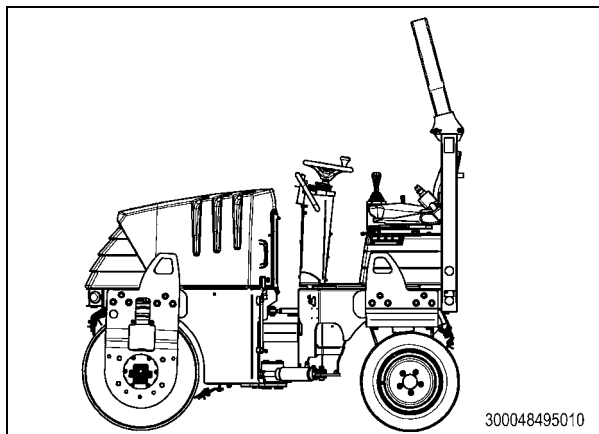

Model	Width	Weight
AV23-2K	1065 mm	2280 kg
AV23-2K S*	1110 mm	2450 kg
AV26-2K	1249 mm	2400 kg
AV26-2K S*	1310 mm	2520 kg
AV32-2K	1219 mm	3110 kg
AV40-2K	1370 mm	3,540 kg

The machine models differ only in terms of weight and the width of the roller drum. The combined roller has a pneumatic wheel axis instead of the smooth back roller drum.

* Roller with open-sided roller drum, S = Side open

The open-sided roller drum option has only one-sided roller drum support, but is labelled the same.

Identification plate



Identification plate

An identification plate (1) is affixed to the roller for identification.

The identification plate is located on the left of the machine on the rear chassis of the roller.

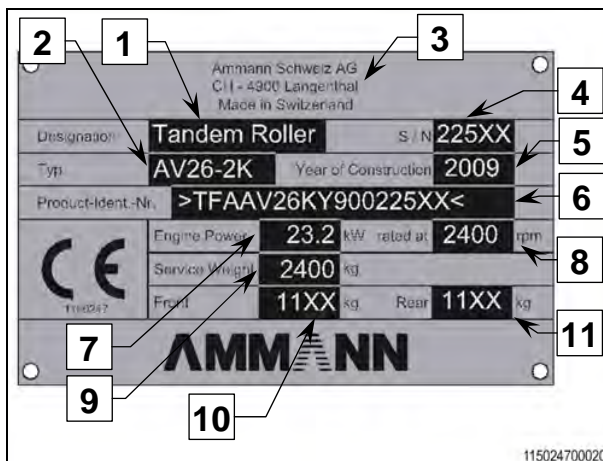

Important data on the identification plate:

- 1 Roller designation
- 2 Roller model
- 3 Name and address of the manufacturer
- 4 Serial number
- 5 Year of manufacture
- 6 Vehicle Identification Number (VIN)
- 7 Fuel engine output at
- 8 Number of revolutions per minute
- 9 CECE gross weight (max. weight CH)
- 10 CECE front axle weight (max. axle weight CH)
- 11 CECE rear axle weight (max. axle weight CH)



NOTE

The roller serial number (S/N) must be specified when ordering spare parts.

Scope of delivery

Scope of delivery

Please check that the delivery is complete and inform us within 14 days after purchase if the delivery is not complete. Please always indicate the serial number.

- Roller
- Roller manual
- Spare parts catalog for roller
- Yanmar engine manual in English
- Yanmar engine manufacturer's declaration

Documents

The following documents are delivered with the machine and may be ordered from Ammann.

	Manual	Spare parts list				
		22'500-	22'500-22'999		23'000-	22'500-
Model	1138310	1120714	1129303	1138127	1138648	1138818
AV23-2	●	●		●		
AV23-2K	●	●		●		
AV26-2	●	●		●		
AV26-2K	●	●		●		
AV32-2	●		●		●	
AV32-2K	●		●		●	
AV33-2	●		●		●	
AV40-2	●		●		●	
AV40-2K	●		●		●	
AV23-2 S*	●					●
AV26-2 S*	●					●

* Roller with open-sided roller drum, S = Side open

3 Safety

General working safety

- The roller may only be used for driving and compacting unbound layers - (gravel, soil) and blacktops (asphalt). Other uses are prohibited.
- Rollers may only be operated with all safety devices operating. Manipulation or non-observation of safety devices and regulations invalidates the CE conformity.
- Before starting every shift, check the effectiveness of the operation and safety devices and that the protection devices are in place.
- Check the steering and brakes when you start work. If defects are apparent roller operation is not permitted.
- If you identify any defects on the safety system or defects that impair safe operation of the equipment, inform your supervisor immediately. The roller may no longer be operated.
- If you identify any defects which endanger safe operation, cease operation immediately.
- Only perform work on and clean the roller if it is stationary and secured from rolling away.
- Switch off the engine when filling the fuel tank. Do not fill up fuel in closed rooms. No naked flames.
- Do not vibrate on slopes or inclines where there is a hazard of slipping or overturning.
- Do not drive on slopes that are steeper than the maximum climbing capacity of the equipment. Always drive the roller carefully perpendicular to the slope dip.
- Do not vibrate inside buildings and on unstable ground.

General working safety

- Keep the driver's position and steps free of trips, grease, dirt, ice, etc.
- The driving and working field of view must not be obstructed in any way. Adjust all the necessary mirrors correctly and keep them clean.
- Switch off the engine before leaving the roller. Secure the roller from unauthorized start-up and rolling away.
- Take suitable measure to secure parked rollers that pose an obstruction.
- Never work under the influence of drugs, alcohol or medicines that impair consciousness.
- Only operate the roller in good general light conditions and good workspace illumination.
- The operator's workplace is on the seat of the driver's platform. The roller may not be operated from any other position.

Roller operation

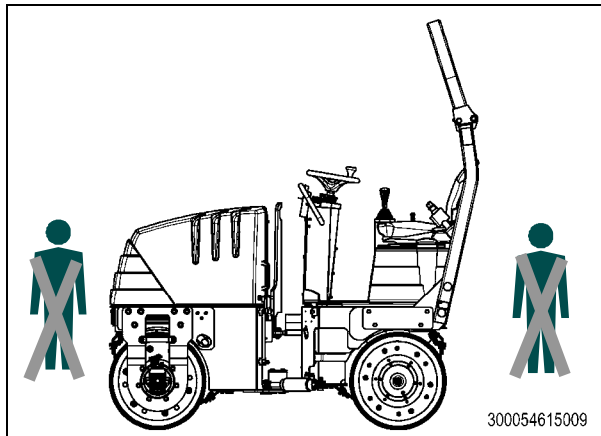

WARNING!

Roll-over hazard!

Only start the roller from the driver's position.

No persons may stand in front of or behind the roller while it is in operation.

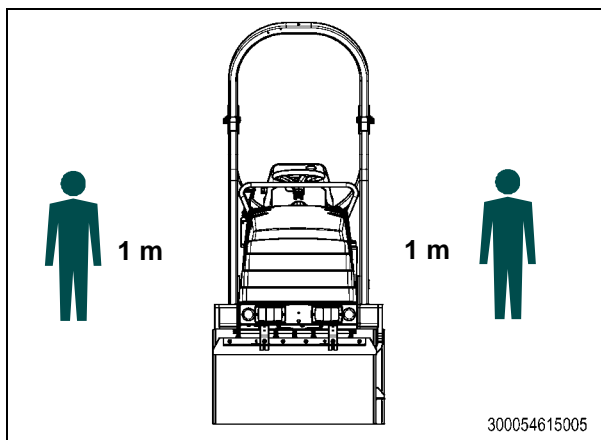

WARNING!

Accident hazard!

Persons necessary for operations at the sides of the equipment must remain at a safe distance of at least 1 m.

Shear points

Keep the following hazards in mind:

- When closing the hood ensure that no objects are situated between the hood and the chassis.
- That nothing is jammed in the joint plates when rotating the roller drums.
- Do not put hands between the roller drum and support during operation.

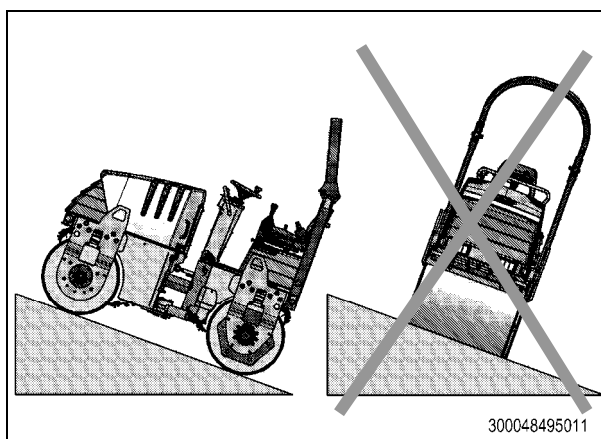

WARNING!

Tipping hazard!

Only travel directly up or down slopes.

Do not drive across slopes.

Roller operation



WARNING!

Tipping hazard!

Keep the following hazards in mind:

- The edges of filled areas may give way!
- Keep your distance to embankments and edges! Do not drive over steps on roadways!
- On embankments, only operate or park rollers in such a way that they cannot tip over.
- The roller drums have very poor adhesion on snow and ice. Driving or working on a slope in snow or ice is prohibited.

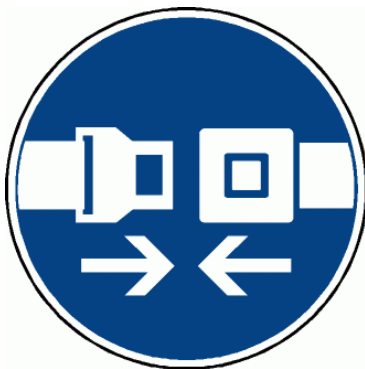

WARNING!

Wear a safety belt!

Keep the following hazards in mind:

- Plane surfaces are not always uniformly load-bearing.
- Cavities or large stones may be located below the surface.
- Loamy/clayey soils become slippery when wet.
- Vibration can increase the hazard of lateral slipping.
- High steering angles at slope edges increase the hazard of overturning.
- Articulated machines are in particular danger from high steering angles on slopes.

Roller operation



 **WARNING!**

Wear safety shoes!

Wear safety shoes when working with the roller in order to help avoid crushed toes.



 **WARNING!**

Read the operating instructions!

Read the operating instructions before operating the roller.

Adhere to the safety regulations at all costs.

Contact your Ammann representative if anything is unclear.

Roll-over bar (ROPS)

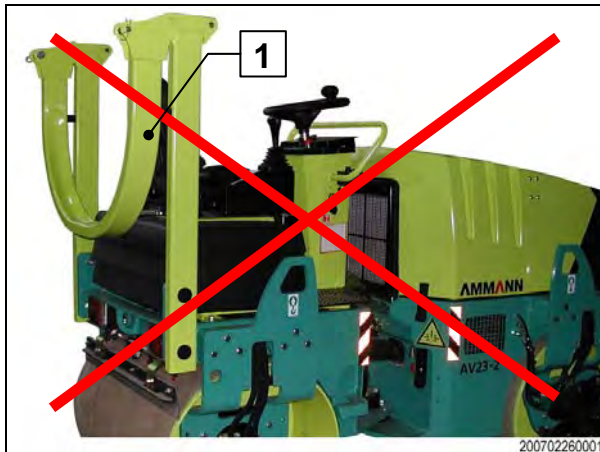

WARNING!

Accident hazard

Never operate the machine with the ROPS (1) folded down!

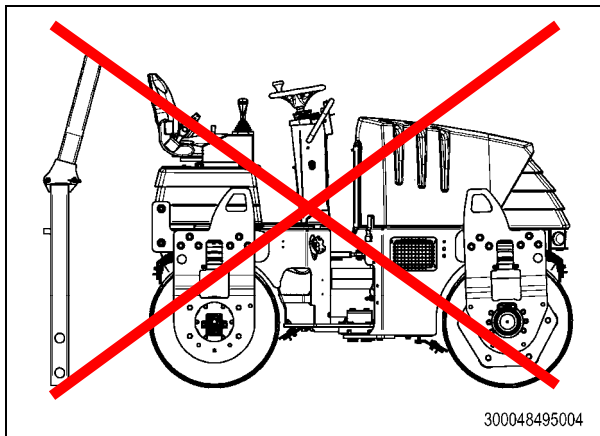

WARNING!

Accident hazard

The ROPS (1) may not be modified in any way without the manufacturer's permission!



NOTE

Check that:

- The roller chassis is not bent or cracked in the area of the ROPS mounting.
- The ROPS has no cracks or fractures.
- All screw connections are tight (observe tightening torque).

Safety markings on the machine

- Observe and adhere to the rules.
- Keep the safety stickers and signs complete and legible.
- Replace any damaged or illegible stickers and signs immediately.
- You can order new stickers from Ammann Schweiz AG.

From the moment the signs are no longer recognizable and understandable at first glance, the machine must be shut down until new signs are installed.



WARNING!

Accident hazard!

If the roller is equipped with a foldable ROPS, the equipment must never be operated with the ROPS - folded down!



WARNING!

Crushing hazard!

Only stand in this area when necessary and only with extreme caution!

Safety markings on the machine



WARNING!

Accident hazard!

You are in the danger zone



WARNING!

Hand injury!

Do not put hands in the radiator fan when the machine is running.



ATTENTION!

Brake wear!

Only activate the emergency stop (parking brake) when the machine is at standstill or in an emergency.

The parking brake closes automatically when the engine is switched off.

Parking brake closes automatically when the seat switch is activated.

Only activate when starting or reversing when the brake control lamp extinguishes.

Safety markings on the machine



 **ATTENTION!**

Damage to electrical controls!

Never spray the water jet into electrical or electronic components.

Never spray into the engine combustion air intake.

Noise levels



WARNING!

Wear ear protectors!

Depending on the use of equipment it is possible that the allowed noise level of 85 dB (A) will be exceeded. Wear ear protectors in accordance with national accident prevention regulations when working at higher noise levels.

Noise levels

The following noise level measurements were carried out by an accredited testing and monitoring body in accordance with machine directive 2000/14/EEC of the European parliament and council.

Inspecting and monitoring organization: TÜV Österreich (Austrian technical inspectorate) Testing body no. 0408

Recorded sound power level:

AV1 = 99 dB(A)

AV2 = 102 dB(A)

Guaranteed sound power level:

AV1 = 103 dB(A)

AV2 = 106 dB(A)

Measured sound pressure level at the driver's position:

AV1 = 86.6 dB(A)

AV2 = 87.7 dB(A)



NOTE

The obligation to wear ear protection is standardized nationally.

In Switzerland and Germany, this applies from a measured level of 85 dB (A) (sound pressure).

Safety (maintenance)



NOTE

Maintenance must only be carried out by trained specialized personnel!

- Only perform maintenance and repair work on the roller if it is static and secured from rolling away.
- Secure the machine with the joint protection.
- Relieve pressure before working on the hydraulic pipes.
- Disconnect the battery before commencing work on the machine's electrical systems. Cover it with isolating material or remove it completely. This does not apply to work requiring an electric current. In the event of injuries caused by acid, rinse immediately with clean water and consult a doctor.
- Replace all protection devices properly after performing servicing and repair work.



WARNING!

Gas poisoning!

Do not leave the engine running in enclosed spaces.

If use of the roller in a confined space cannot be avoided, the exhaust fumes must be extracted directly from the exhaust pipe.



ATTENTION!

Damage to electrical controls!

Never spray the water jet into electrical or electronic components.

Never spray into the engine combustion air intake.

Safety (maintenance)



ATTENTION!

Hydraulic control failure!

Hydraulic tubes decompose.

Refitting used machines for use with biodegradable hydraulic oils is prohibited!

If hydraulic hoses on a machine running on synthetic ester HE need replacing, only those declared by the supplier as being compatible with synthetic esters may be used.

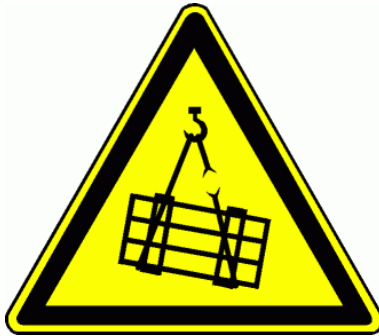

WARNING!

Danger to life!

- Always use an accident-proof support when working on a raised machine.
- Never work below a machine supported only by a crane or other electrical/hydraulic lifting device.
- Only stand under a raised machine if it has been mechanically secured.
- Use only stable loading ramps suitable for the weight of the machine for loading.
- On transport vehicles, correctly secure the roller against rolling, slipping and overturning.

Safety (maintenance)



ATTENTION!

Battery acid!

The battery electrolyte contains sulfuric acid and is poisonous and concentrated enough to burn holes in clothes and skin. If it gets into eyes it can lead to blindness.

- Protect the battery from fire, flames and sparks.
- Protect the battery from mechanical damage.

ATTENTION!

Charging the battery!

- Never check the battery charge level with a metal object. Use a voltmeter or the battery's charge indicator.
- When disconnecting the battery always disconnect the negative terminal first (-). Connect the positive terminal (+) first when reconnecting.

ATTENTION!

Damage to electrical controls!

Always remove the battery completely before performing welding work on the machine.



NOTE

Always replace the battery with a service-free battery.

If a battery requiring maintenance is used, the safety regulations given in the battery operating instructions must be adhered to.

Safety (maintenance)



! WARNING!

Burns hazard!

Never remove the expansion cap or radiator cap while the engine is running or hot!

First loosen the cap to the first stop to release the pressure. Only then remove the cap.



! WARNING!

Trapping hazard!

Only open the engine hood when the engine is switched off.

If it is absolutely necessary to work on moving parts (engine or machine) for troubleshooting, never wear necklaces, bracelets, scarves, ties or other loose clothing. If any of these get caught in moving parts there is a danger of serious injury!



! WARNING!

Burns hazard!

- Only work on a cool engine.
- Keep enough distance to the exhaust.



! ATTENTION!

Environmental hazard!

Do not allow any liquids to enter drains, the soil or the environment.

Vibration hazard

Whole-body vibrations

The acceleration data given below for the three directions were measured in accordance with Directive 2002/44/EC of the European Parliament and Council. According to this directive the following shall be taken into consideration for risk assessment:

- Extent, type and duration of exposition as well as limit values
- All impacts on the health and safety of the roller driver
- Information provided by the roller manufacturer

The following represent typical ground compaction activities with and without vibration. The impact duration shall be taken into consideration when calculating the daily exposition.

Acceleration data in m/s^2 according to ISO 2631-1 for whole-body vibration

Activity	$a_{w,eqx}$	$a_{w,eqy}$	$a_{w,eqz}$
Ground compaction with vibration	0.226	0.203	0.213
Ground compaction without vibration	0.351	0.243	0.102

Activity	VDV_x	VDV_y	VDV_z
Ground compaction with vibration	1.16	1.23	3.14
Ground compaction without vibration	3.21	2.97	0.43



NOTE

The acceleration data are dependent on the methods used and the ground properties; that is, the values may deviate from those given.

The actual exposure can be determined using a whole-body vibration exposure calculator.

4 Transport / Commissioning

Transport

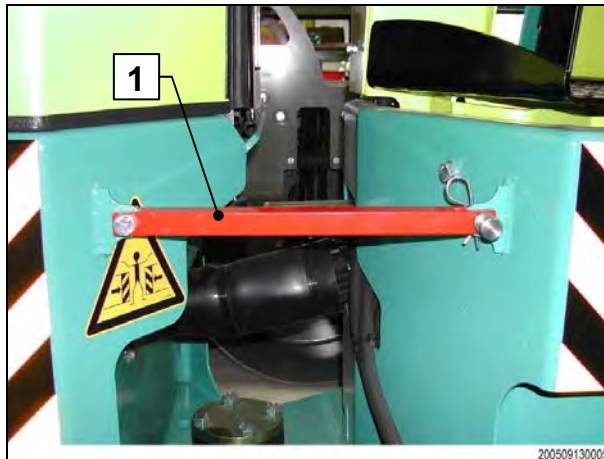

Articulated joint lock

 **WARNING!**

Danger of crushing

Before lifting, during transport of the machine, you must install the lock (1) of the articulated joint (joint protection).

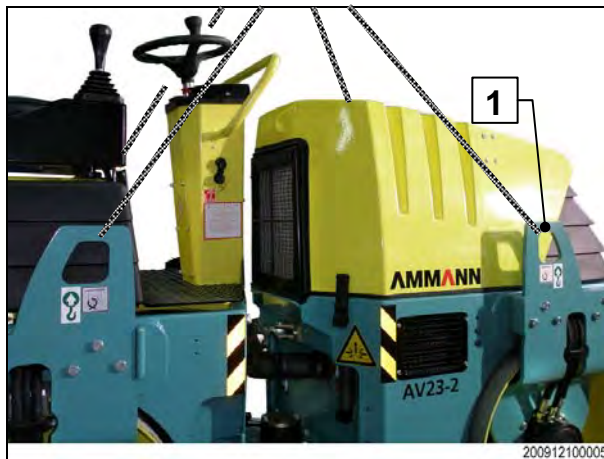

Lifting at the 4-point lifting eyes

Lift the roller with suitable tools using the four lifting eyes (1) integrated into the wheel suspension.



NOTE

The lifting devices (steel ropes, etc.) must be at least 2,300 mm long.



WARNING!

Accident hazard!

- Do not stand under suspended loads!
- Use only anti-slip, stable ramps when loading!
- Secure the machine on transport vehicles to prevent it from rolling away, slipping to the side or tipping over!



NOTE

The roller will weight less if the water tanks are drained before transporting.

Transport

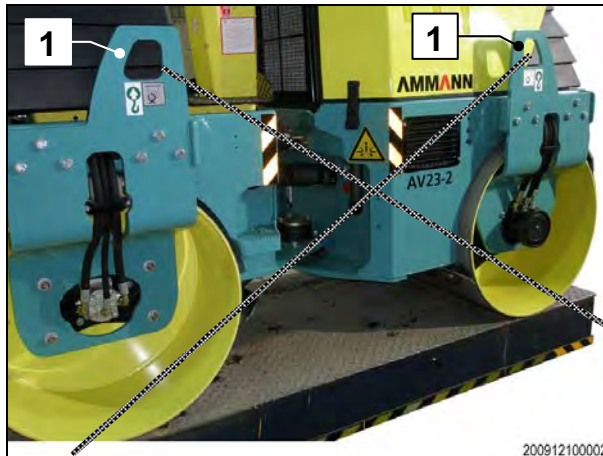

Securing the roller

Brace down the roller at the four wheel suspensions **(1)**.

Secure the machine from rolling away forward or backward.

Now secure the roller from slipping sideways.



CAUTION!

A blocked steering system can lead to accidents!

Open the joint protection before starting the machine.

Dimensions relevant to transport

Model	Length* (mm)	Width (mm)	Height* (mm)	Weight (kg)
AV23-2	2563	1121	1937	2515
AV23-2 S	2563	1140	1937	2755
AV23-2K	2563	1065	1937	2385
AV23-2K S	2563	1110	1937	2555
AV26-2	2563	1326	1937	2765
AV26-2 S	2563	1340	1937	2955
AV26-2K	2563	1249	1937	2505
AV26-2K S	2563	1310	1937	2625
AV32-2	2563	1310	1937	3265
AV32-2K	2563	1219	1937	3215
AV33-2	2563	1412	1937	3555
AV40-2	2563	1412	1937	3905
AV40-2K	2563	1370	1937	3645

* With ROPS folded down

Center of gravity

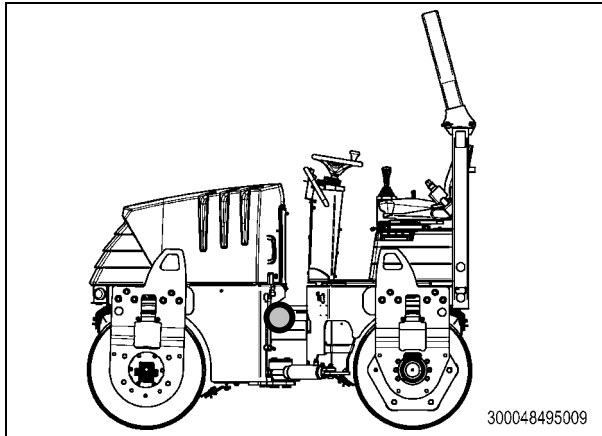

The center of gravity relevant to transport is located 710 mm from the floor and approx. in the center of the machine, depending on the fill level of the diesel or water tanks.

Joint protection

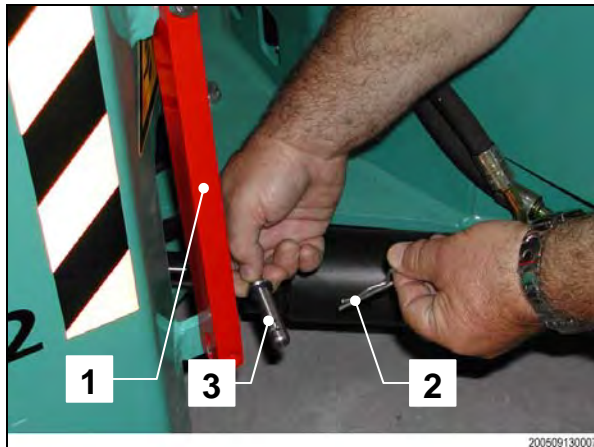

Blocking the joint protection

Detach the bottom part of the joint protection (1) by first pulling out the compression spring (2) and then the lock bolt (3).

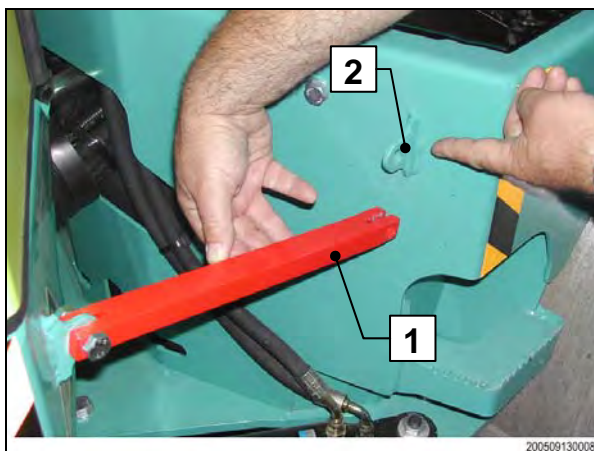

Carefully turn the roller steering wheel until the joint protection (1) comes in line with the opposite loop (2).



NOTE

You must start the machine to be able to move the steering wheel.



WARNING!

Danger of crushing

Person standing in the danger zone: Switch off the engine once the machine is aligned.

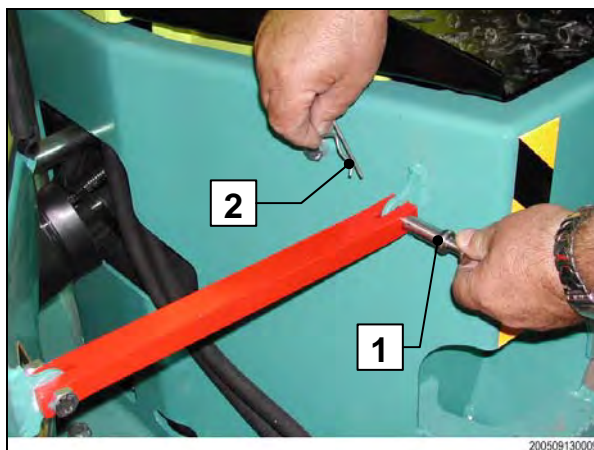

Now snap in the joint protection and secure it with the lock bolt (1).

Secure the lock bolt with the compression spring (2).

Commissioning

The machine as delivered is essentially ready for operation. Observe the following before commissioning:

- Familiarize yourself with the manual.
- Perform ten-operating-hours maintenance. This procedure is described in the "Maintenance" section.
- Make sure that the joint protection is open.

Roller with pneumatic wheel (combined roller)

- If using a combined roller, you must check tire pressure and adjust as required. The ex works pressure is set to 2.5 bar.
- Tire pressure must be adjusted to suit the compaction condition of the ground:

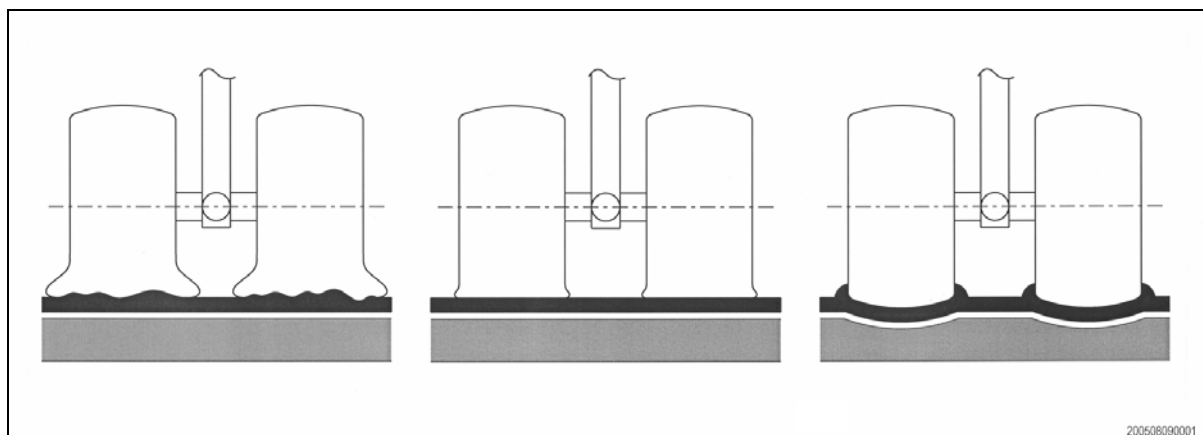

Tire pressure too low

Tire pressure OK

Tire pressure too high



NOTE

The tires must be replaced if the fabric is visible on the tire surface.

Commissioning

Wide tires

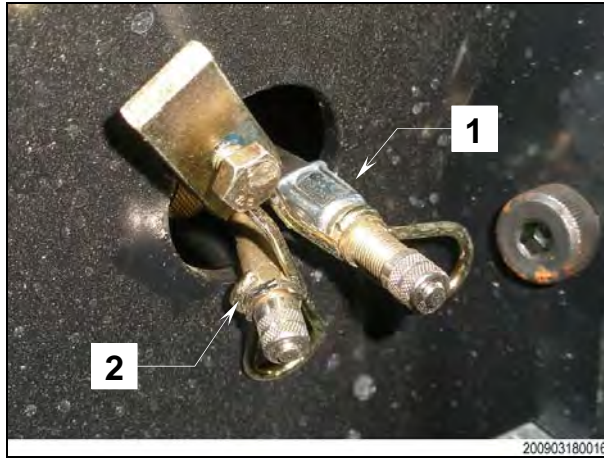

Valves

Two tires on each side are connected to each other. The valves for inflating the tires come through the same opening.

The valve **(1)** with the hose leads to the inner tire.

The valve **(2)** with the tube leads to the outer tire.

5 Overview

Intended use

Intended purpose of the AV2-2

AV2-2 vibration rollers are universal rollers designed for use on small and medium-sized building sites. Ammann rollers are effective and efficient compacting machines when it comes to installing blacktops and compacting unbound soil and gravel.

Requirements for roller operators

Only trained, suitable and reliable specialists with a valid national driving license for this category of vehicle may operate the rollers.

Limits of application under different climatic conditions

	Operation	Storage
Temperature limits	-10°C to +48°C	-10°C to +48°C
Humidity	All-year operation/outdoor storage	
Terrain	Graded	Graded
Upslope	30% with/40% without vibration	40%
Downslope	30% with/40% without vibration	40%

Normal modes of operation

The AV2-2 roller may only be used for driving and compacting unbound layers (gravel, soil) and blacktops (asphalt).

Special operating modes

- Transport of the machine from A to B (crane & low loader)
- Cleaning the machine
- Maintenance of system components according to maintenance plan or in the event of defects
- Rectification of machine faults by trained personnel based on error messages.
- Towing the roller
- Proper disposal by the operator in accordance with national regulations

Inappropriate use

Inappropriate use includes any use not listed under intended use. Note the following in particular:

- The machine is not a playground.
- The machine must not be used for traction.
- The machine is not a passenger transporter.
- In the case of movements greater than 3 km, the machine must be loaded on a transporter.
- The machine is not a rock crusher, breaking chisel or similar.

Disclaimer

Ammann Schweiz AG accepts no liability for maintenance of reliable functioning of the roller if it is not used appropriately.

Unauthorized conversions and changes to the machine are prohibited for safety reasons.

Spare parts used when replacing defective or wearing parts must conform to the technical specifications stipulated by Ammann. These requirements are fulfilled if only original Ammann spare parts are used.

The instructions given in the various sections must be adhered to. The safety instructions must be observed at all times. Failure to adhere to working instructions, their correct order, safety instructions or safety labeling requirements causes liability claims to become void.

Component overview

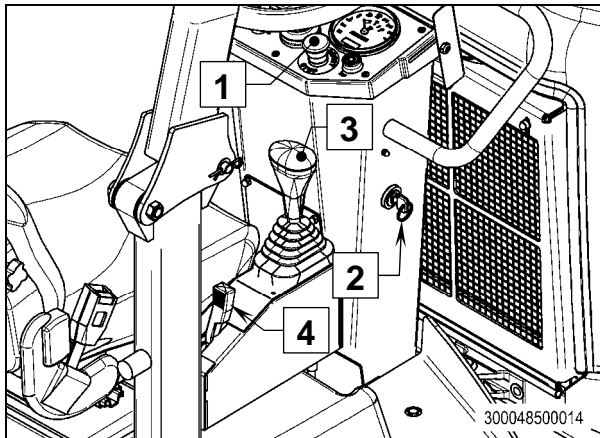

- 1 Emergency stop switch
- 2 Ignition switch
- 3 Operating lever
- 4 Speed regulating lever

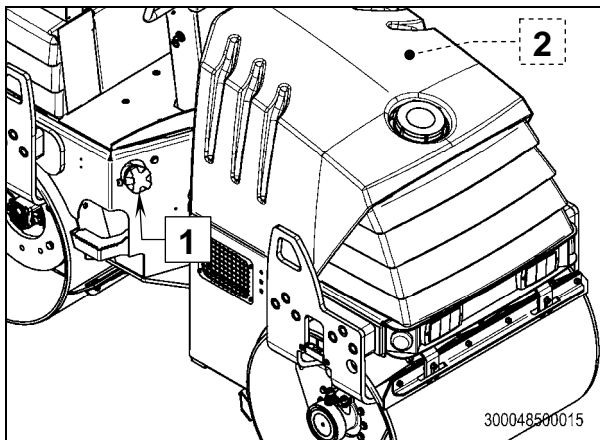

- 1 Tank cap (diesel)
- 2 Document holder, under the Hood

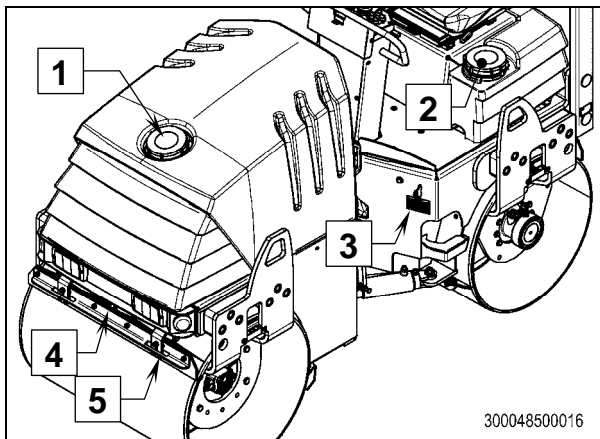

- 1 Cap (front water tank)
- 2 Cap (rear water tank)
- 3 Identification plate
- 4 Front spinkler
- 5 Roller drum scraper

Component overview

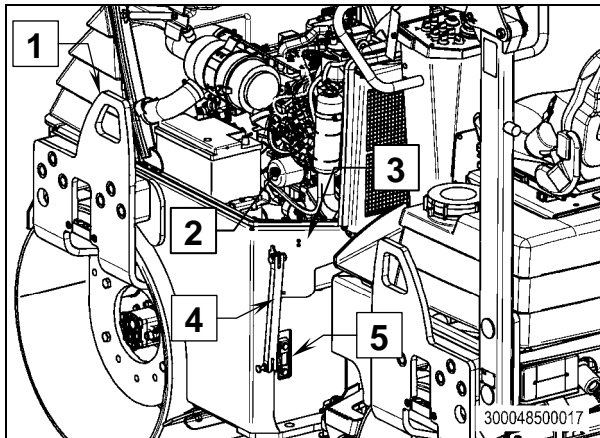

- 1 Suspension
- 2 Engine oil filter
- 3 Hydraulic oil filter
- 4 Articulated joint protection
- 5 Hydraulic tank oil level indicator (optical)

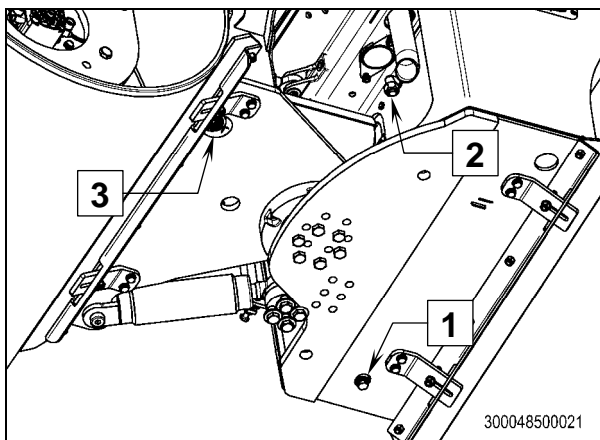

- 1 Hydraulic oil drain
- 2 Engine oil drain
- 3 Diesel tank drain

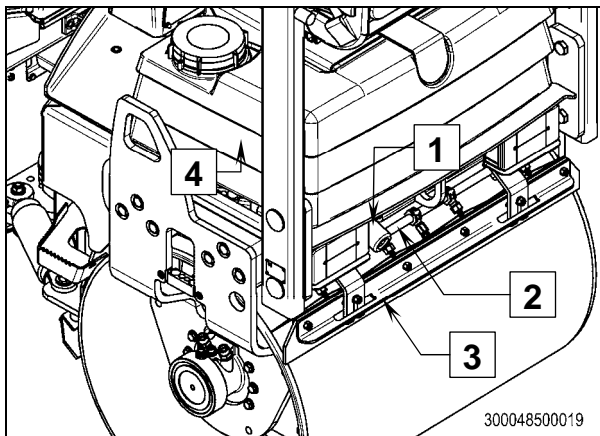

- 1 Water filter
- 2 Rear sprinkler
- 3 Roller drum scraper
- 4 Water pump (below the water reservoir)

Dashboard (switches)

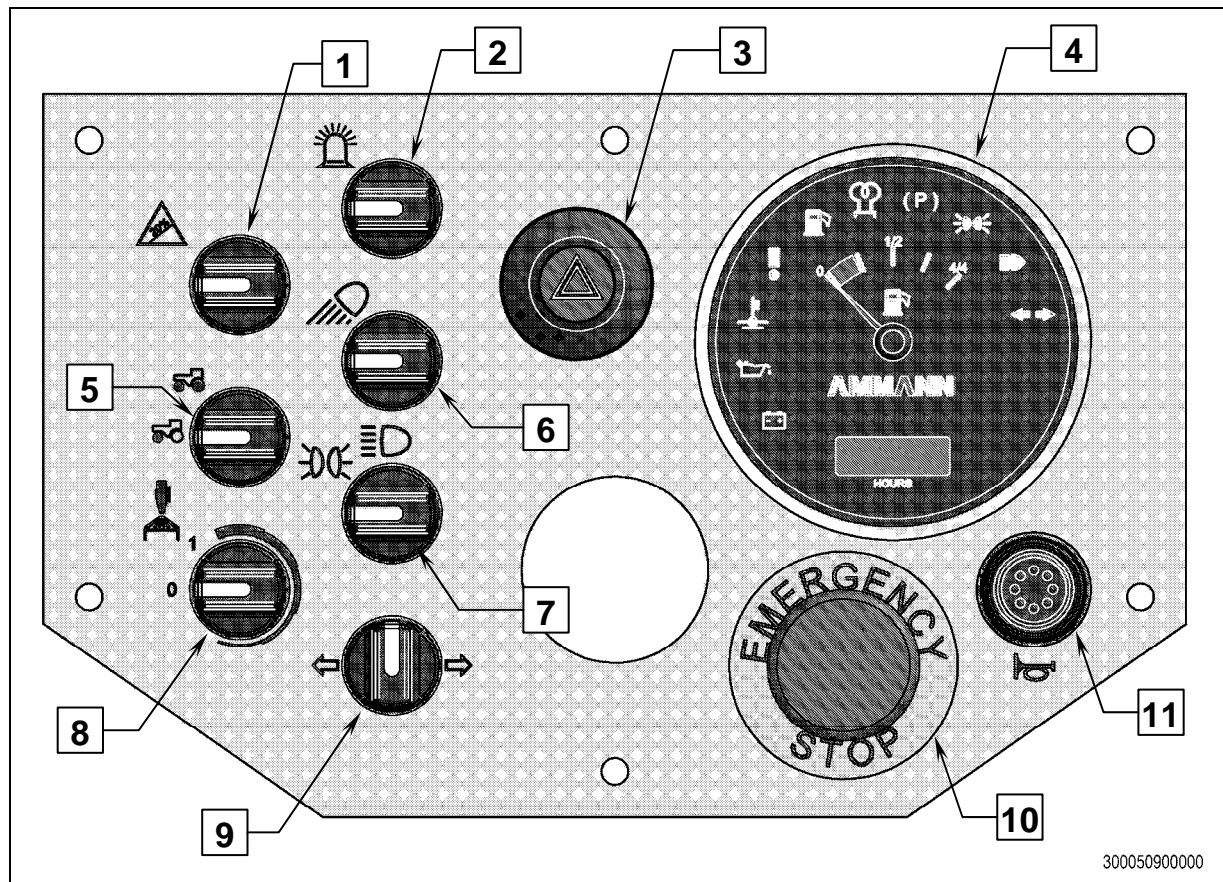

30005090000

- 1 Operating switch for improved climbing (traction aid/flow divider)
(Optional for AV2-2 only)
- 2 Switch for revolving warning light **(optional)**
- 3 Operating switch for hazard flasher **(only with light option)**
- 4 Multifunction device with hour counter
- 5 Selector switch – vibration front or front and rear **(optional)**
- 6 Operating switch for work light **(only with light option)**
- 7 Operating switch for light **(only with light option)**
 - 0 – Off
 - 1 – Parking light
 - 2 – Main beam light
- 8 Continuous sprinkling switch (standard) or sprinkling interval switch
(optional)
- 9 Indicator switch left/right **(only with light option)**
- 10 Emergency stop switch
- 11 Horn

Dashboard (control lamps)

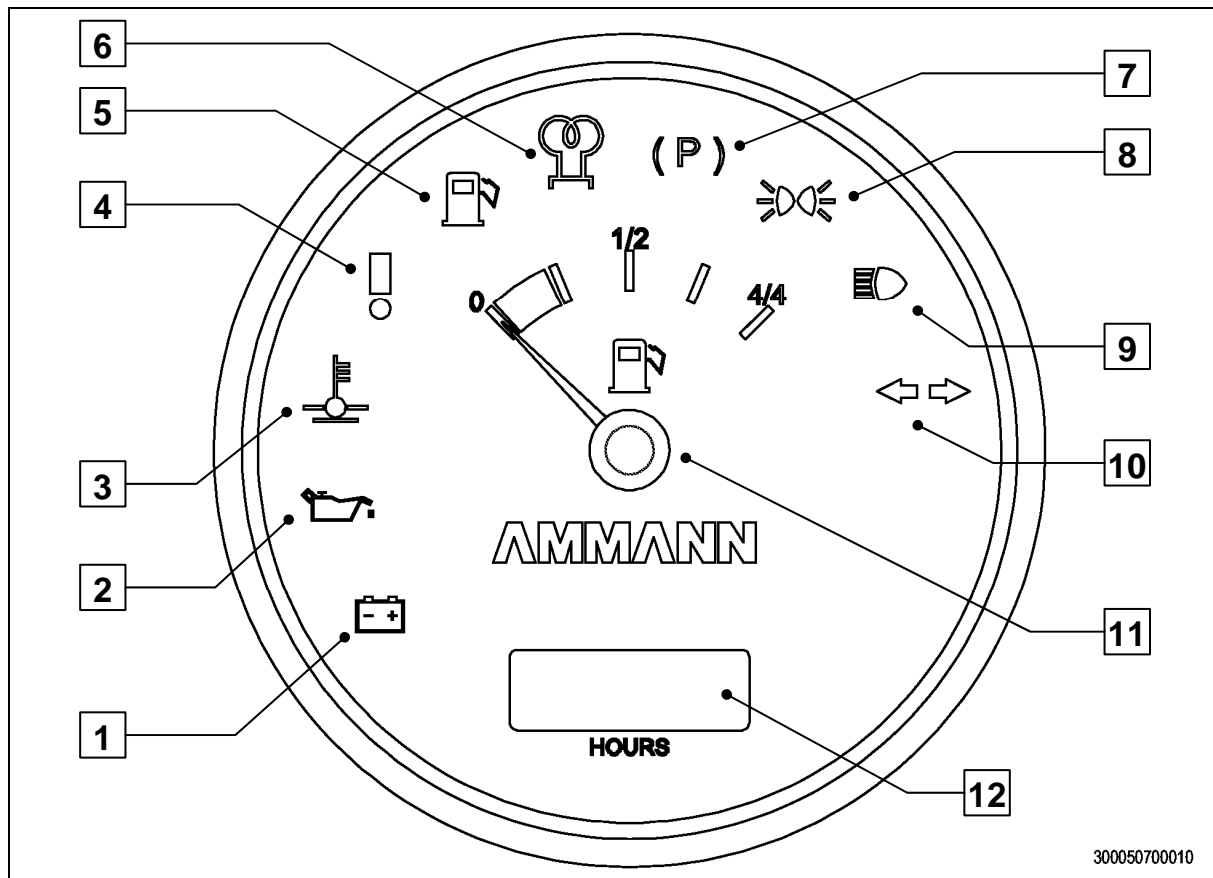

- 1 Control lamp for battery charge level (charge control)
- 2 Engine oil pressure control lamp
- 3 Engine coolant temperature control lamp
- 4 Control lamp for emergency stop circuit, operating lever zero position and seat contact
- 5 Fuel reserve control lamp
- 6 Control lamp for pre-heating
- 7 Control lamp for brake release and supply pressure hydraulics
- 8 Control lamp for parking light
- 9 Control lamp for road driving light
- 10 Indicator control lamp
- 11 Fuel tank display
- 12 Operating hours counter



ATTENTION!

The warning lamps for engine oil pressure, charge indicator and brake release/supply pressure must light up when the ignition is switched on. They must go off as soon as the engine is started.

Operation check



1 Battery charge level control lamp

If the battery charge level control lamp lights up during operation or does not go off after starting, carry out the following check immediately.

1. Stop the engine
2. Check the engine for defective or loose V-belt.
3. If the battery charging lamp is still lit after carrying out these checks, call a specialist to help solve the problem.

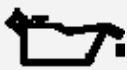

2 Engine oil pressure control lamp



ATTENTION!

Stop immediately!

If the engine oil pressure control lamp lights up during operation or does not go off after starting, turn off the engine immediately!

1. Check the engine for oil loss and correct oil level.
2. If the engine oil level is correct, call a specialist to help solve the problem.



3 Engine coolant temperature control lamp



ATTENTION!

Stop immediately! Engine overheating!

If the coolant temperature control lamp lights up during operation of the machine, switch off the engine immediately and top up coolant!



WARNING

Danger of scalding! The cooling circuit is pressurized.

1. Allow the engine to cool down before removing the radiator cap.
2. In order to avoid scalding, first unscrew the radiator cap $\frac{1}{4}$ of a turn and allow the pressure to drop.

Operation check

3. As soon as the pressure has dropped, remove the cap and top up the liquid.
4. Check the cooling system for leaks and the radiator/ expansion vessel for correct coolant level.
5. If you cannot locate the fault, call a specialist to help solve the problem.



4 Control lamp for emergency stop circuit, operating lever neutral position and seat contact

If the control lamp lights up while the ignition is on, observe the following:

1. Release the "EMERGENCY STOP" button by turning it clockwise (red mushroom button on the instrument panel).
2. Put the operating lever into neutral position.
3. Sit on the driver's seat.
4. If the battery charging lamp is still lit after carrying out these checks, call a specialist to help solve the problem.



5 Fuel reserve light

After the lamp lights up for the first time, the fuel in the tank will last at least ½ h. Top up diesel fuel.

- Tank volume: 43l



6 Diesel engine pre-heating

- Pre-heating time: 15 seconds.

The lamp extinguishes when the engine is started.

Operation check

(P)

7 Control light for hydraulic brake release and supply pressure

As long as this control lamp is lit, the brake release and supply pressure of the hydraulic system is not sufficient. Do not start to drive until this control lamp has gone off.



WARNING!

If the control lamp for the hydraulic brake release/supply pressure lights up while driving or does not go off after starting the engine, the machine must not be driven any further.

1. Check whether the seat contact switch is closed.
2. If the seat switch is closed and the control lamp is still lit, call a specialist to help solve the problem.

6 Operating

Driver's seat



NOTE

The driver's seat is important for your health. Adjust the seat to suit your body size.

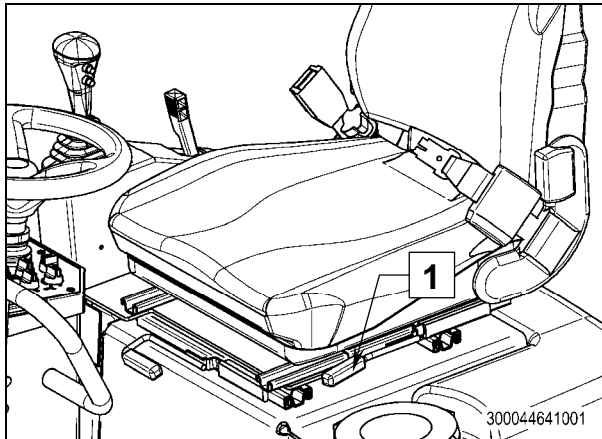

Forward/backward adjustment

Push lever **(1)** upwards gently and adjust the seat to the desired position.



NOTE

If adjusted ergonomically forward/backward, your feet will be on the floor panel.

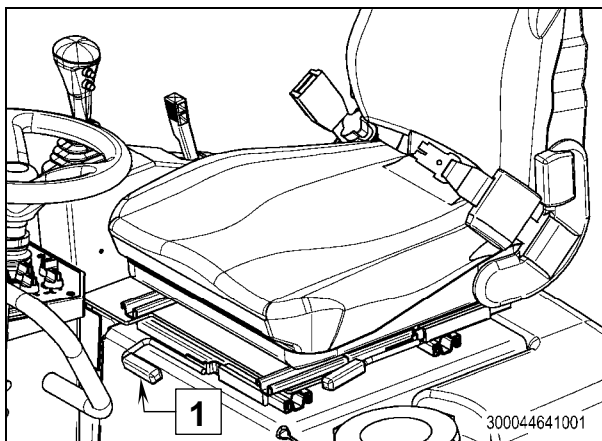

Transverse adjustment (AV2-2 only)

Pull lever **(1)** up and adjust the seat to the desired position.

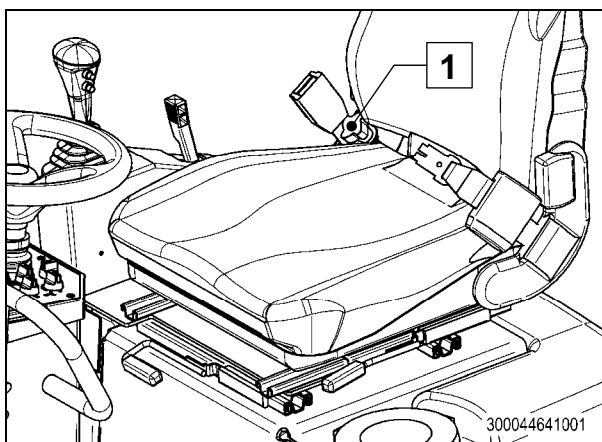

Adjusting the backrest

Turn the adjuster button **(1)** clockwise to move the backrest backward.

Turn the adjuster button **(1)** counterclockwise to move the backrest forward.

Driver's seat

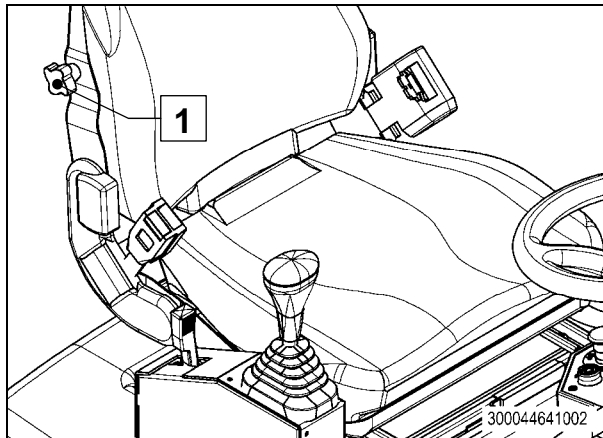

Weight adjustment

Turn the adjuster button **(1)** clockwise to reduce tension of the seat.

Turn the adjuster button **(1)** counter-clockwise to increase tension of the seat.

Weight adjustment is infinite in the range of 50 – 120 kg.



WARNING!

Accident hazard!

Do not adjust the driver's seat while driving – increased risk of accidents!

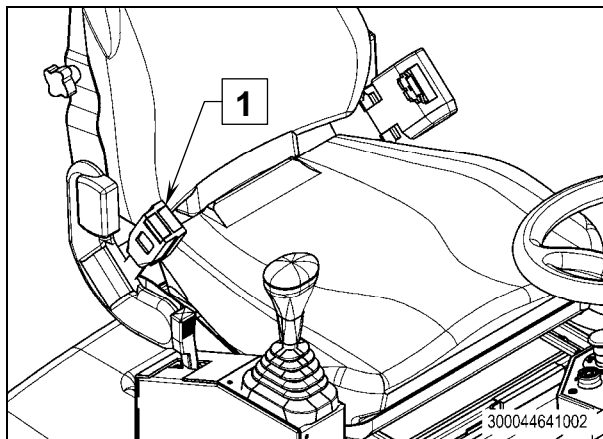

WARNING!

Accident hazard!

Wear a safety belt!

Always wear the safety belt **(1)**. Together with the roll-over bar it is a safety system that can save your life.



WARNING!

Crushing hazard!

Never place your feet on the bend **(1)** of the floor panel. There is a risk of crushing when the roller moves out to the sides.

Roll-over bar (ROPS)



WARNING!

Accident hazard!

The ROPS must be in the up position during operation.

The ROPS is only folded down for transport purposes.

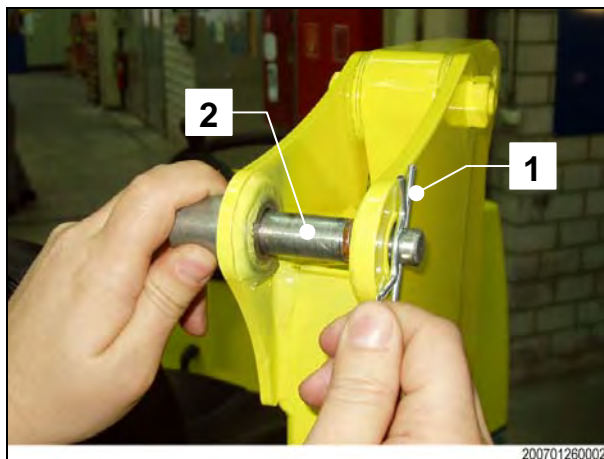

Putting up the ROPS

First, remove the split pin (1) and then the bolt (2).

Place the parts on the rear water tank or on the seat. They should be easy to reach when you come to refit them.



Lift the ROPS until it remains upright alone.

Stand in the driver's position and pull the ROPS all the way up.

Roll-over bar (ROPS)



Fit the two bolts and split pins.
You may need to use a bar to tighten
the bolts.



Both sides must be secured with bolts
and split pins during operation.



WARNING!

Accident hazard!

Never stand below the ROPS when
lowering. The ROPS can fall as
soon as it crosses its center of
gravity.

Starting the engine

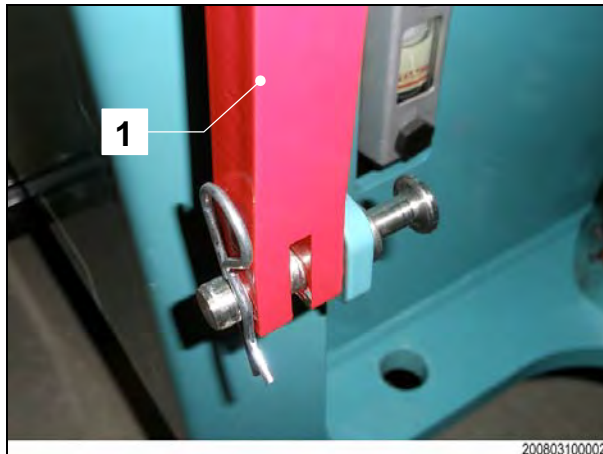

Joint protection

Ensure that the joint protection (1) is secured as shown and the safety spring is engaged.



WARNING

Accident hazard

When the joint protection is secured the steering is blocked.



Protection against vandalism

Ensure that the vandalism protection (1) is clapped fully to the rear as shown in the image.

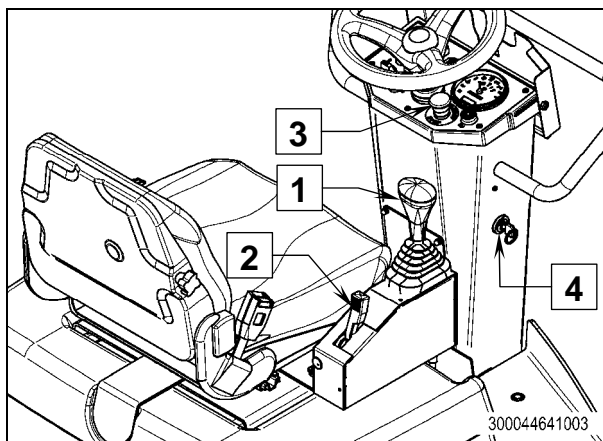

Driver's position

- 1 Drive lever
- 2 Speed adjusting lever
- 3 Emergency-stop button
- 4 Ignition switch

If the driver's seat is occupied, the seat switch releases the controls.

The seat switch must not be shorted.

If the emergency stop button (3) is activated, release it by rotating it clockwise once. In the "America" version release the emergency stop button by pulling upwards.

Starting the engine

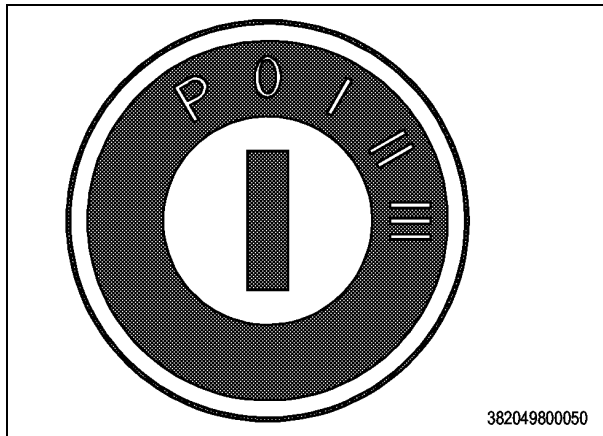

Ignition switch positions

P PARKING

In this position you can switch on the parking light. The remaining electrical loads are off.

0 OFF

All electrical loads are powered off.

I Ignition on

All electrical consumers can be switched on.

II Pre-heating

III Start

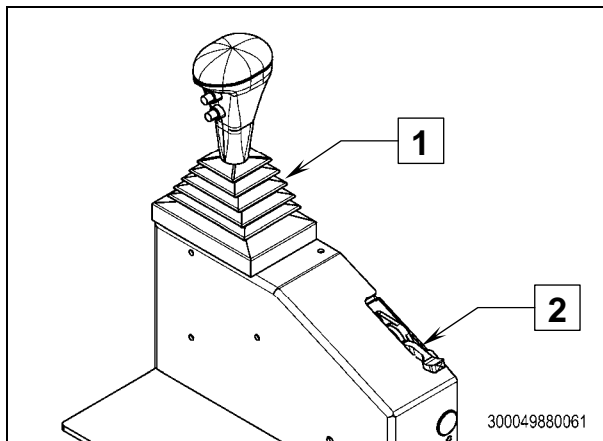

Operating lever (1)

Move the operating lever **(1)** into the neutral position until it locks in.

The diesel engine cannot be started in any other position.

Speed adjusting lever (2)

Move the speed adjusting lever **(2)** fully to the rear into the idle position.



NOTE

The machine may only have one speed, depending on the options fitted.

Starting the engine

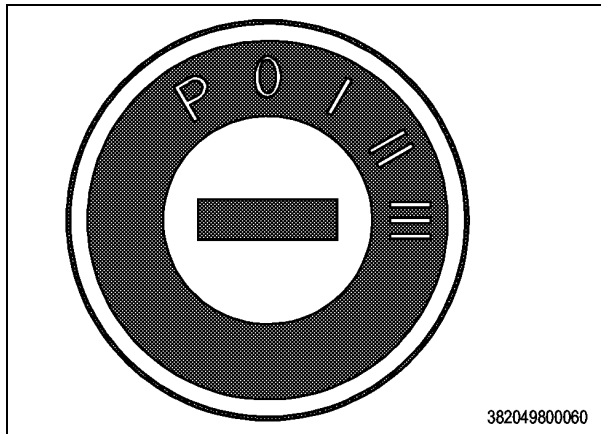

Start procedure

Turn the ignition key clockwise to position III.

Release the ignition key as soon as the engine starts.



NOTE

The control lamps for engine oil pressure, charging, hydraulic brake release/supply pressure light up when the ignition is switched on. They extinguish once the engine is running.

Pre-heating

If the outside temperature is below 0° C, first turn the ignition key to position II, hold it in this position for 15 seconds, and then turn it to position III.



ATTENTION!

When starting and driving a cold machine, with cold hydraulic oil, braking distances are longer than if the oil has reached normal working temperature.

Driving and braking

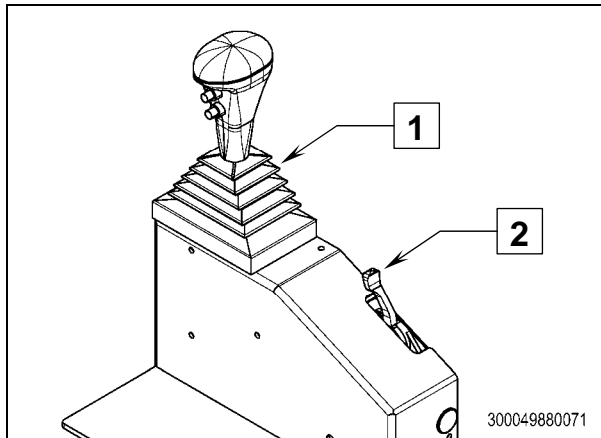

Speed regulating lever (2)

Move the speed adjusting lever (2) forward until it snaps into first position.

The engine is now running at the first operating speed.

The machine also operates at an additional, higher speed, depending on the model.

Move the speed adjusting lever (2), without using excessive force, forward again until it snaps into the second position. The engine is now running at the second operating speed.

Check whether the steering is working.

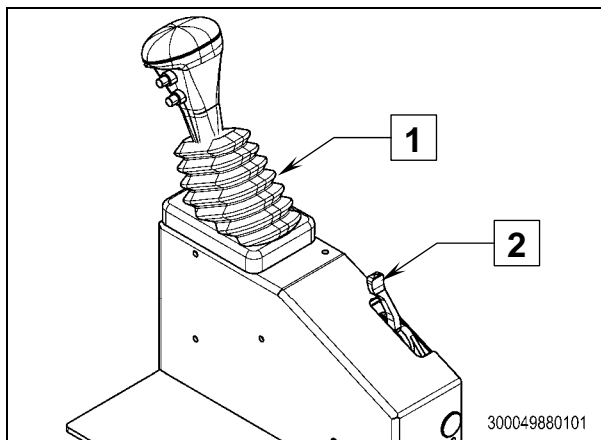

Forwards

Move the operating lever (1) slowly forward.

The machine moves forward.

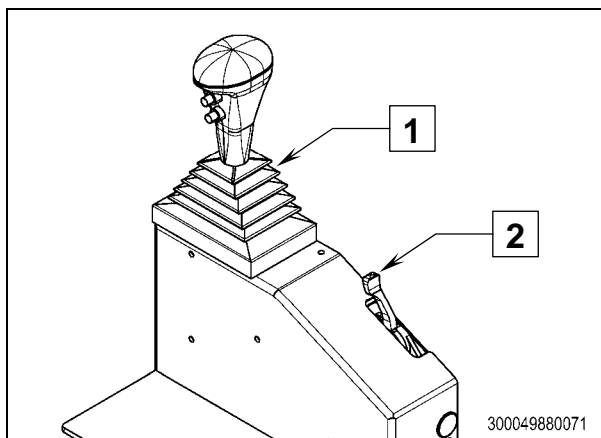

Braking (service brake)

Slowly pull the operating lever (1) into neutral position.

The machine is automatically hydrostatically braked.

Driving and braking

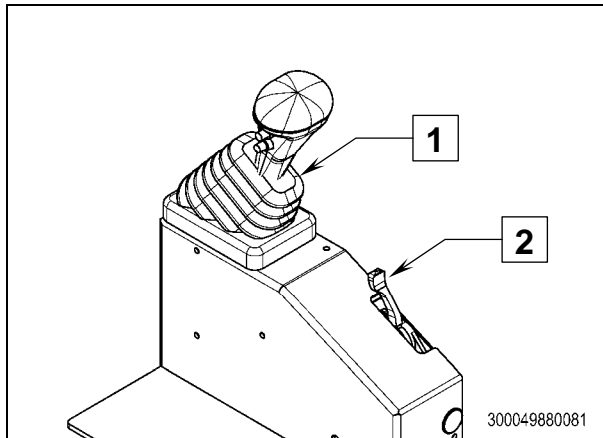

Driving backwards

Move the operating lever **(1)** back slowly.

The machine moves backward.

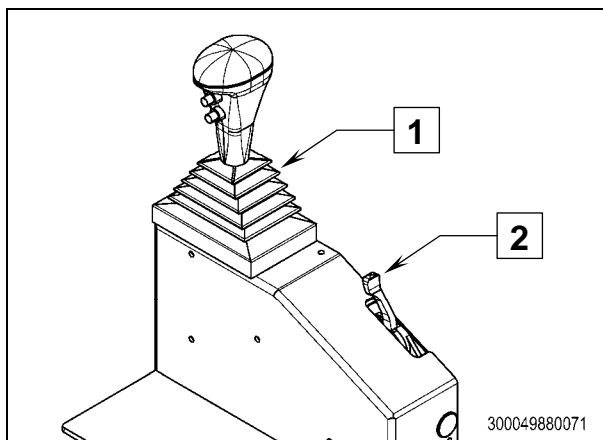

Braking (service brake)

Slowly push the operating lever **(1)** into neutral position.

The machine is automatically hydrostatically braked.



ATTENTION!

Self-locking!

If the operating lever is released it does not automatically return to the neutral position. The lever remains at its current position.

Working speed

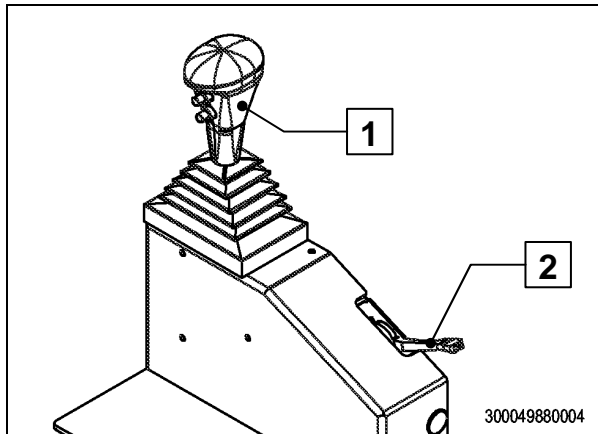

Speed regulating lever (2) – vibration frequency selection

The machines have two operating speeds.

This allows improved adaptation of speed and vibration power to specific ground conditions



NOTE

The machine may only have one speed, depending on the options fitted.

Idling speed

The speed adjusting lever (2) is at the rearmost position.

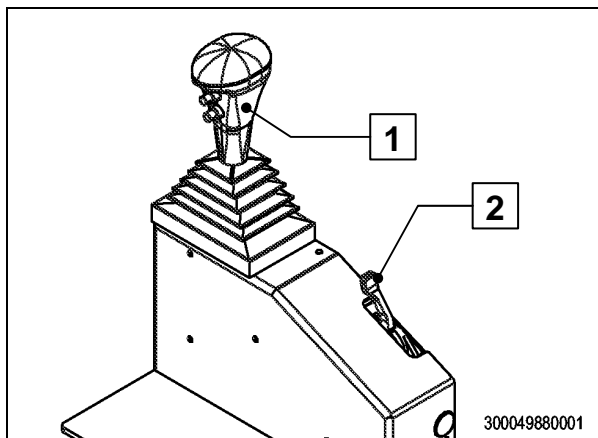

Low working speed

Low speed - low frequency

Move the speed adjusting lever (2) forward until it snaps into first position.

The engine is now running at low speed.

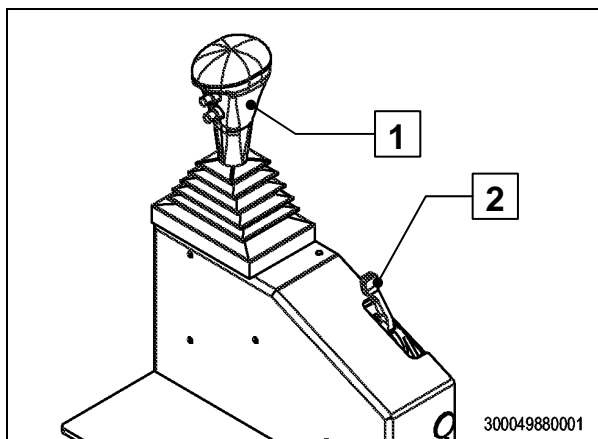

High working speed

High speed - high frequency

Move the speed adjusting lever (2) forward again until it snaps into second position.

The engine is now running at high speed.

Turning off the engine

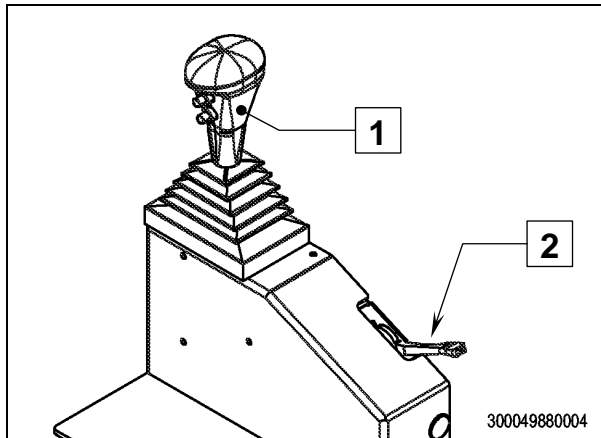

Operating lever (1)

Slowly push the operating lever (1) into neutral position. The machine is automatically hydrostatically braked.

Speed regulating lever (2)

Move the speed regulating lever (2) all the way to the idle position.

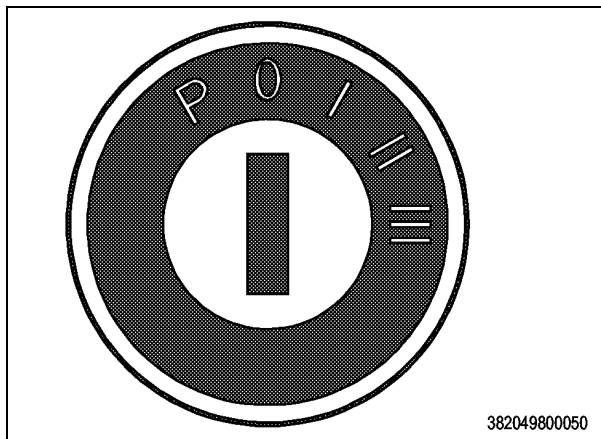

Turning off the engine

Turn the ignition key counterclockwise back to position 0.

The engine stops.

If you want to turn on the parking light, turn the ignition key to position P.

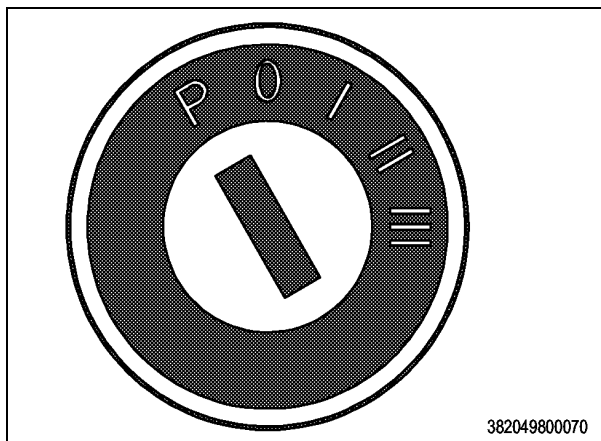

Ignition switch

P PARKING

In this position you can switch on the parking light. The remaining electrical loads are off.

0 OFF

All electrical loads are off.

I Ignition on

All electrical consumers can be switched on.

II Pre-heating

III Start



NOTE

The hazard warning light can be switched on and off independently of the ignition key position.

Emergency stop

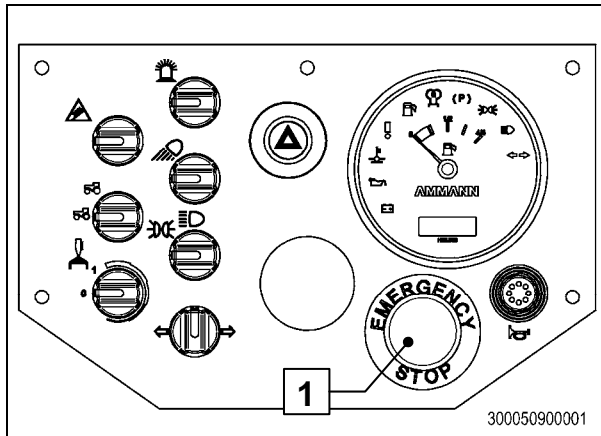

Activating the emergency stop

Press the emergency stop ("EMERGENCY STOP") button (1) in emergencies.

The machine comes to a standstill immediately.

The engine shuts down immediately and automatically. The brakes are activated.

WARNING

Only press the emergency stop in an emergency.

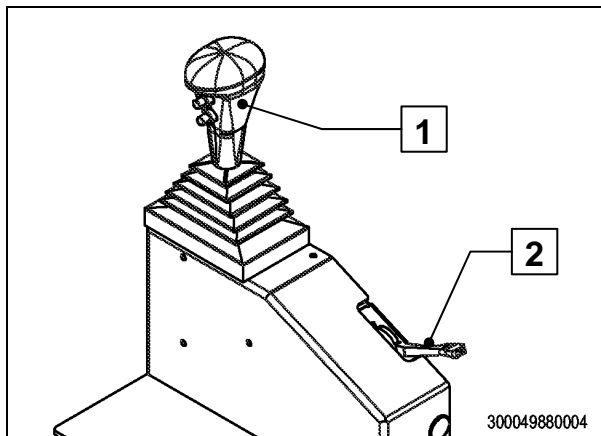

Releasing the emergency stop

First move the operating lever (1) to neutral position.

Then move the speed adjusting lever (2) all the way back.

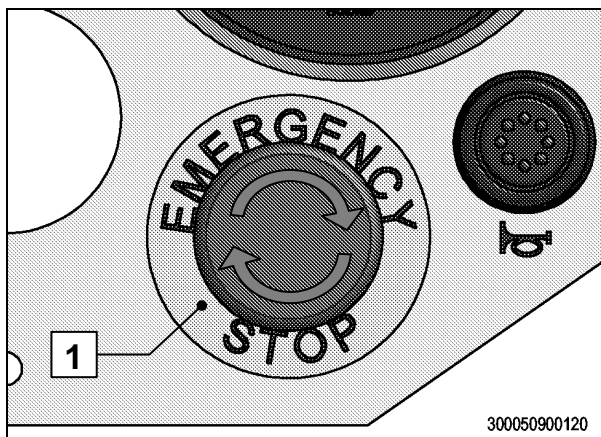

Now turn the emergency stop button (1) slightly in the direction of the arrow until it disengages.

NOTE

Release the emergency stop button by pulling upwards in the "pull-push" version. The direction arrows are missing from this button.

The machine is now ready for operation.

Parking brake

The vibration roller is equipped with an automatic parking brake.

The drive motor brakes are activated when the supply pressure drops below 12 bar or when the EMERGENCY STOP button is pressed.

When you press the EMERGENCY STOP button a valve reduces supply pressure and the brakes take immediate effect.

The parking brake closes automatically when the diesel engine is switched off.



WARNING

- In order to save the brakes from unnecessary wear, only perform an emergency stop in emergency situations when driving.
- Only use the parking brake in special cases, e.g. when you stop on a slope. If the machine starts to roll, move the operating lever slightly in the opposite direction, so that the vehicle is kept still hydrostatically.

Sprinkling



Checking water level

Open tank screws on both water tanks, rear **(1)** and front **(2)**, and top up water if required.

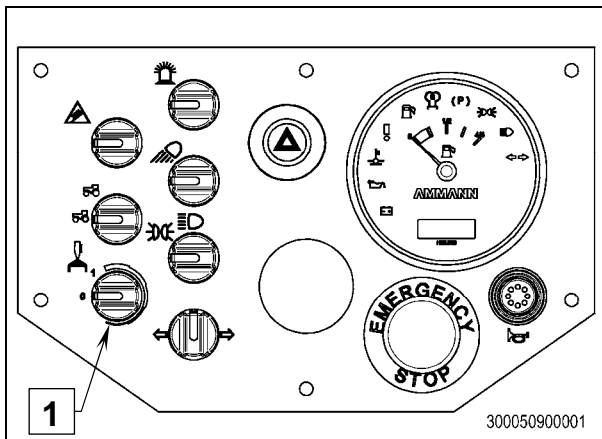

Switching continuous sprinkling on and off

Turn the sprinkler switch **(1)** from position 0 to 1 to activate continuous sprinkling.

Interval sprinkler option

The roller is optionally equipped with an interval sprinkler.

In this case, please refer to the “Options” section on the “Interval sprinkler” page.



ATTENTION!

If your machine is not equipped with an interval sprinkler avoid turning the switch too far to the right. In this case you can only select positions 0 and 1.

Sprinkling

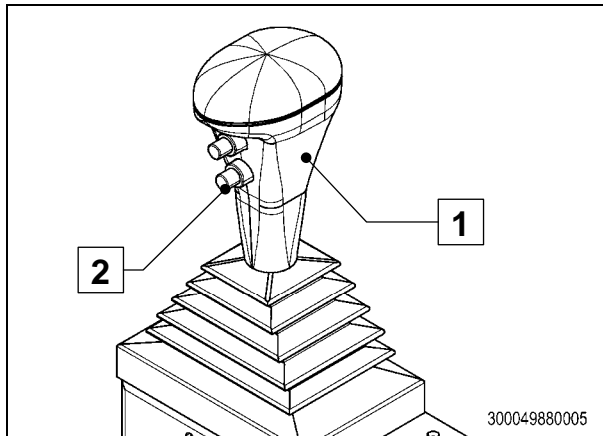

Operating lever sprinkling (1)

To operate the sprinkler from the operating lever (1) press the bottom button (2). The sprinkler stays on as long as you are pressing the button.



NOTE

In the combined roller, drive lever sprinkling is used only for tire sprinkling.

Simple/double vibration

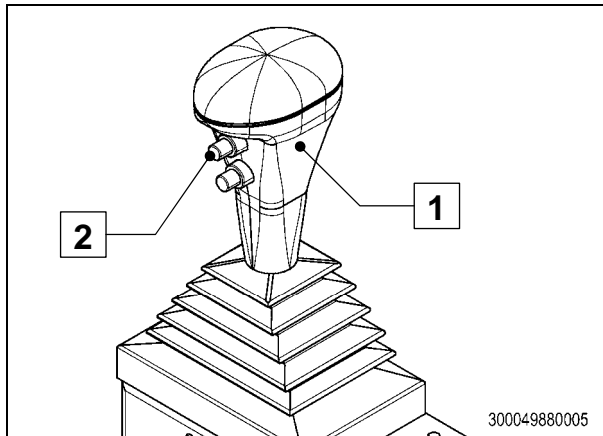

Switching on vibration

Press the top button (2) briefly on the operating lever (1).

Switching off vibration

Press the same button (2) again briefly.



ATTENTION!

Never use vibration while idling!

Only switch vibration on if the speed adjusting lever is set to a work speed.

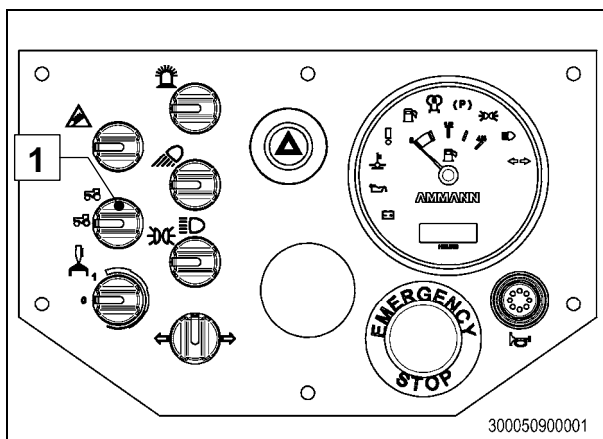

Front and rear vibration

In order to activate front and rear vibration, turn the vibration selection button (1) clockwise.

Front only vibration

Turn the vibration selection button (1) counterclockwise.



ATTENTION!

Accident hazard!

- Do not vibrate on slopes or inclines where there is a hazard of slipping or overturning.
- Do not vibrate inside buildings and on unstable ground!
- Never use vibration while at a standstill!

7 Options

Edge cutter

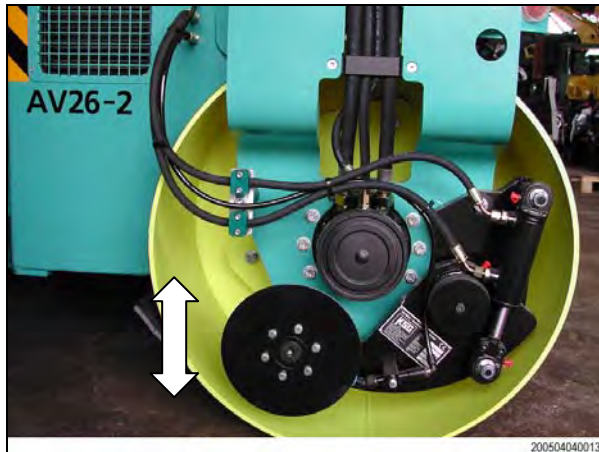

WARNING!

Risk of injury!

Persons are not allowed in the hazard zone when raising or lowering the edge cutter.

Keep to a safety distance of at least 1 m.

The edge cutter can be operated via the operating switches or the operating lever, depending on the machine configuration.

Operating via the operating switches

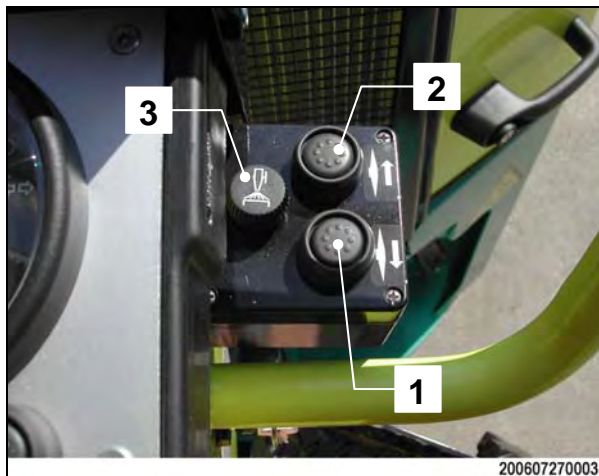

Operating switch position

The edge cutter operating switch is located at the right of the steering column

Lowering the edge cutter

As long as you press the "Lower" button **(1)** the edge cutter is lowered.

Raising the edge cutter

As long as you press the "Raise" button **(2)** the edge cutter is raised.

Edge cutter sprinkler

The rotary switch **(3)** switches on the water supply (continuous sprinkling) to the edge cutter.



NOTE

This function only works if roller drum sprinkling is switched on.

Edge cutter

Operating via the operating lever

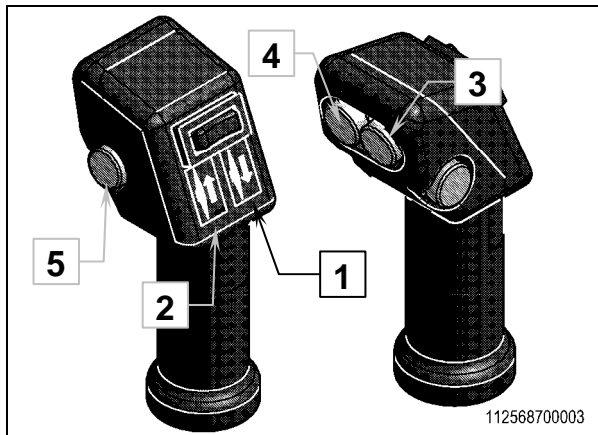

Lowering the edge cutter

As long as you press the "Lower" button **(1)** the edge cutter is lowered.

Raising the edge cutter

As long as you press the "Raise" button **(2)** the edge cutter is raised.

Edge cutter sprinkler

The roller drum sprinkler is switched on for as long as the "Sprinkler" button **(3)** is pressed.

The "Water" button **(4)** switches on the water supply to the edge cutter.



NOTE

This function only works if continuous roller drum sprinkling is switched on.

Vibration

Vibration is switched on as soon as the "Vibration" button **(5)** is pressed.



NOTE

Vibration is prohibited as long as the edge cutter is down.
Raise the edge cutter before switching on vibration.

Edge cutter

Disk use and storage

A cutting disk and a pressure disk are included in the edge cutter's scope of delivery.

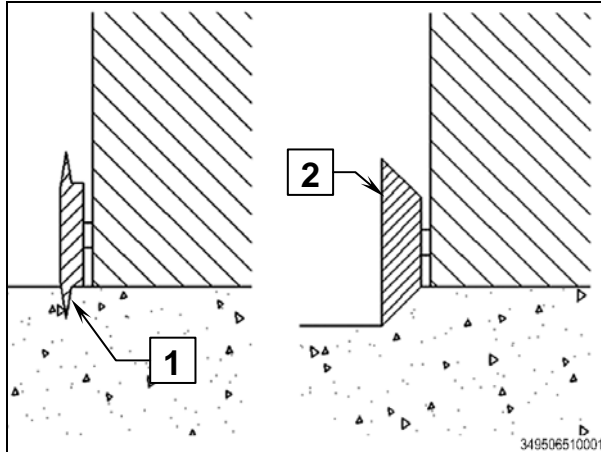

Cutting disk (1)

Using the cutting disk the pavement can be cut at the required position or pavement edges can be straightened.

Pressure disk (2)

The pavement edges are compacted at an angle using the pressure disk.

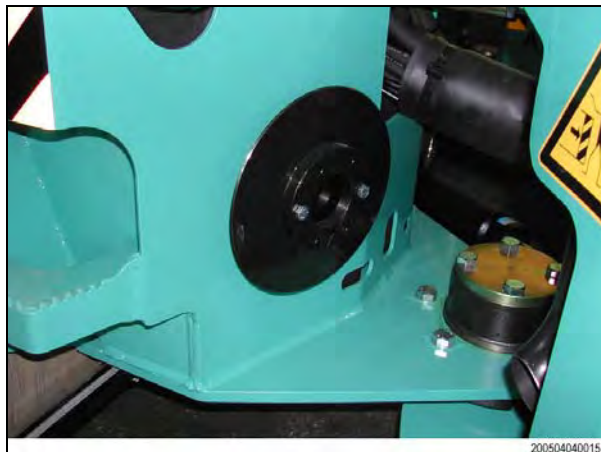

Disk storage

If one of the two disks is not being used, fix it to the mounting provided on the right side of the roller.

ATTENTION!

Risk of injury!

The disk can loosen and injure nearby persons!

Check the fastening screws when replacing the disks.
Tighten the screws well on both the edge cutter and the mounting.

See the "Tightening torques" table in Section 8 Servicing.

Revolving warning light

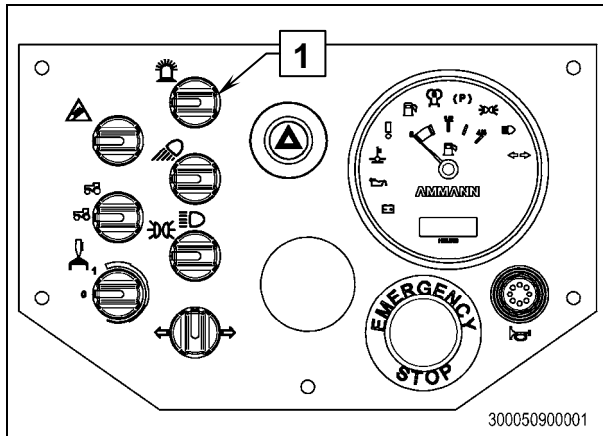

Switching on the revolving warning light

Turn the switch **(1)** to the right to switch on the revolving warning light.



NOTE

The machine may be fitted with a revolving warning light, but the corresponding switch may be missing. In this case the revolving warning light operates continuously as soon as the ignition key is in position II.

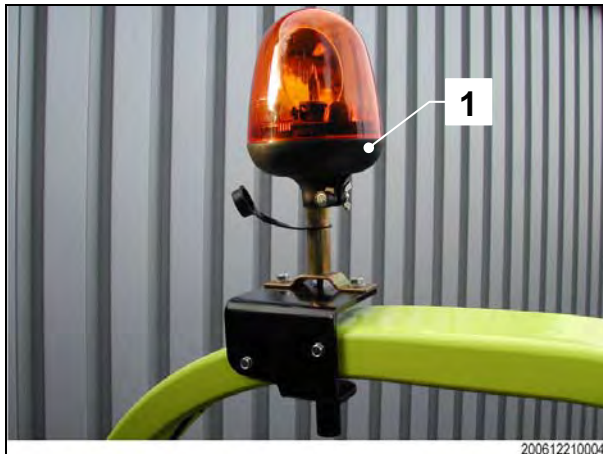

Position during operation

The revolving warning light **(1)** is located at the back right on the roll-over bar (Rops) during operation.



WARNING

Risk of injury!

The revolving warning light must always be installed at the top if the ROPS is up.

The light may only be operated at the top.

Revolving warning light



Position when not in operation

Fold the rollover protection (ROPS) down for transport or during extended periods of non-use.

The revolving warning light can be attached to the holder on the inner right of the roll-over protection (ROPS).

Make sure that the fastening screw **(1)** is tightened.



Replacing the bulb

Undo the anti-theft screw **(1)**.

The hood can be removed by rotating it to the right.



Press the two lugs of the bulb holder together.

Revolving warning light



You can now remove the bulb from the holder.
Now pull the bulb off the plug and replace it with a bulb of the same type and power.



NOTE

Do not touch the glass of the new bulb with your fingers. Sweat on your hands can burn into the glass and reduce bulb lifetime.

Roof

The roof option serves as all-weather protection. You can use the roof to protect from sun and rain.

Transport with ROPS folded down

During transport with the ROPS folded down, e.g. in a container or closed truck, you must remove the whole roof.

Fitting / removing the roof

Please note the work/assembly instructions contained in the delivery: (ANW-4397 roof option AVM-2).

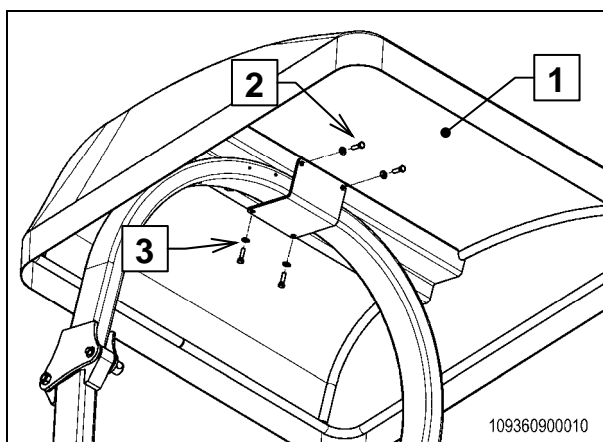

Fitting the roof

Screw the roof (1) to the ROPS with the four Allen screws (2) and washers (3).



NOTE

Make sure that the screws are always firmly tightened.

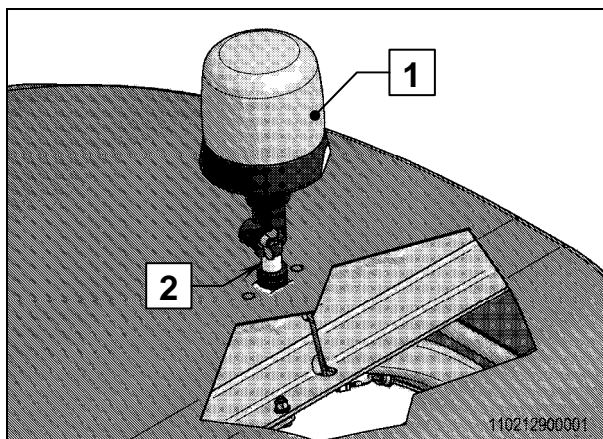

Roof with revolving warning light

If your roller is fitted with a revolving warning light (1), disconnect the wing nut of the revolving warning light (2) before removing the roof. Lift the warning light out of the holder.

Roof

Transport with ROPS folded up



ATTENTION!

Material damage and hazard to road traffic

You must remove the tarpaulin during transport on an open truck.

The pressure of the head wind can cause the material to tear or come off and endanger traffic coming from behind.

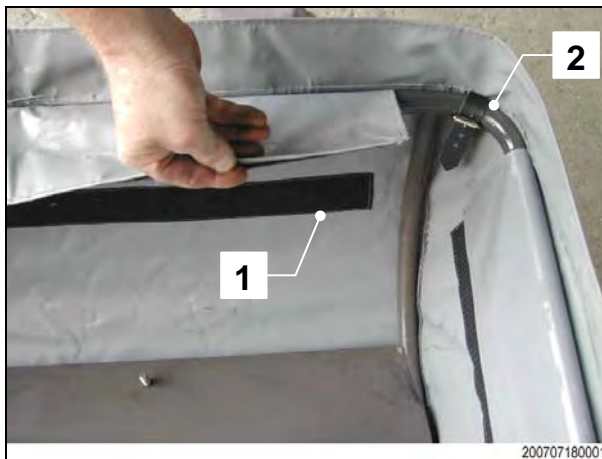

Removing the tarpaulin

Detach the hook-and-pile fastener **(1)** on the sides and the leather straps **(2)** in the corners.

You can now remove the tarpaulin.

Driver's platform cover



The driver's platform and the instrument panel can be protected from dirt and water using the driver's platform cover (1).

Transport on open transporter



ATTENTION!

Material damage

You must remove the tarpaulin during transport on an open truck.

The material may be ripped in the headwind.



Assembly

Fit the cover so that the type designation AV1 or AV2 is to the rear.

Secure the elastic ropes as shown in the figure.



Secure the elastic ropes as shown in the figure.

Reverse alarm

The reverse alarm is active as soon as the roller drives backward. The alarm stays on until the roller starts to drive forward or comes to a standstill.



WARNING!

Roll-over hazard!

Get out of the danger zone immediately!

Noise data

97dB +/- 4dB to SAE J 994, Oct. 03

Battery cut-off switch

The battery cut-off switch interrupts the power supply from the battery to the machine. Switch off the battery cut-off switch if the roller is not in operation for longer than two days.



ATTENTION!

Short-circuit!

Always disconnect the power supply when working on the electrical system.

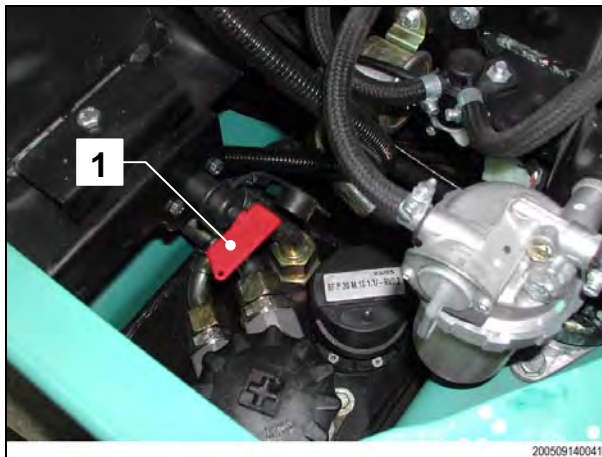

Battery cut-off switch position

The battery cut-off switch **(1)** is located under the cowling right next to the battery.

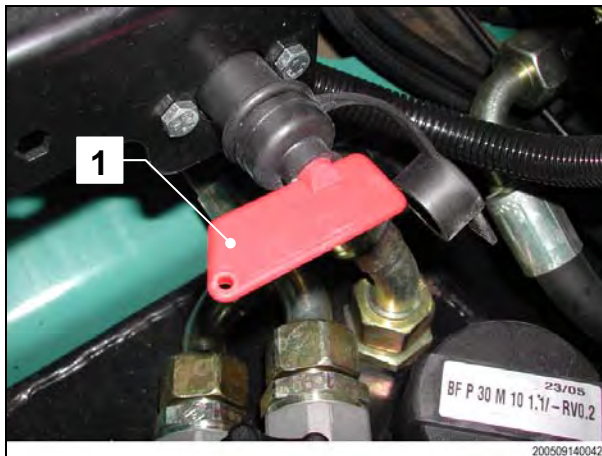

Switching on the power

Turn the red key **(1)** of the battery cut-off switch left to horizontal position.

If fitted, the roller is now supplied by the starter battery.

Battery cut-off switch

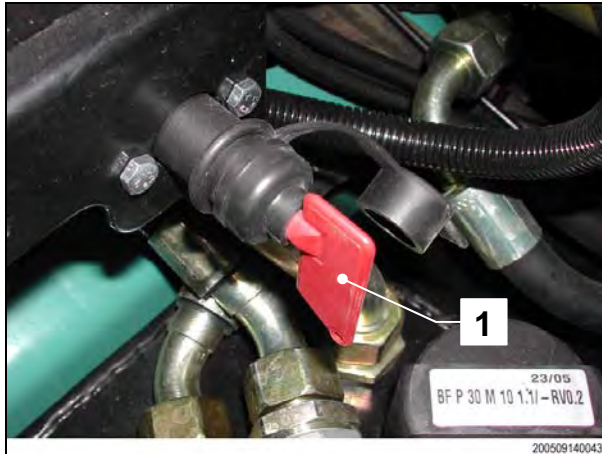

Switching off the power

Turn the red key **(1)** of the battery cut-off switch down to vertical position.

This interrupts the power supply.

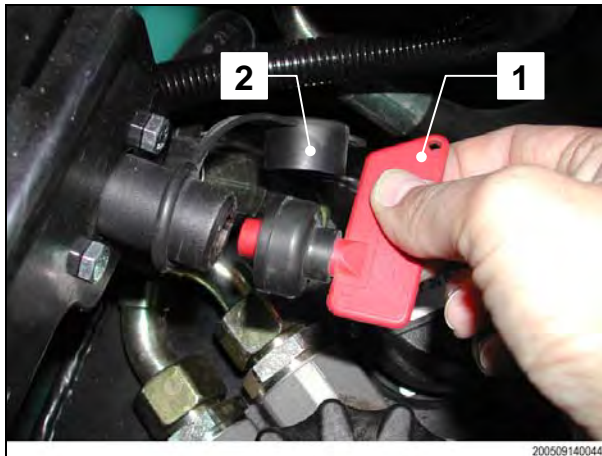

Removing the key

Turn the red key **(1)** of the battery cut-off switch right to final position.

You can now remove the key.

Close the keyhole using the cap **(2)** provided.

Traction aid (flow divider)

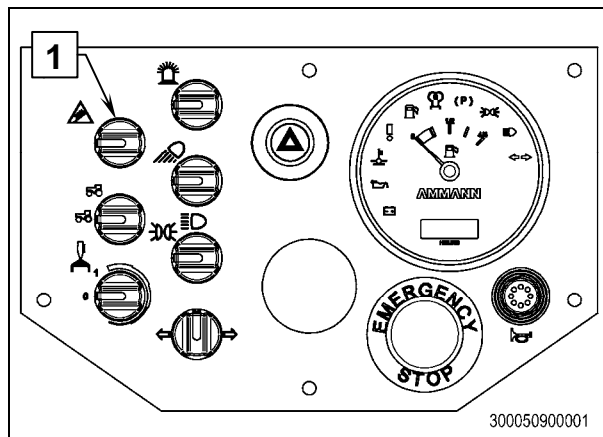

The flow divider ensures equal drive of the front and rear wheels and thus avoids free rotation of one wheel.

This function is useful for negotiating inclines with poor adhesion qualities (e.g. loading the roller via a loading ramp).

Turn the switch **(1)** to activate the "traction aid" function; you will hear an acoustic signal.

ATTENTION!

Hydraulic system heat-up!

The traction aid is active as long as the switch is in the "traction aid" position. This function is not required in normal operating mode. If constantly activated the hydraulic system is additionally unnecessarily heated.

Only engage the traction aid when the machine is at standstill.

Lighting

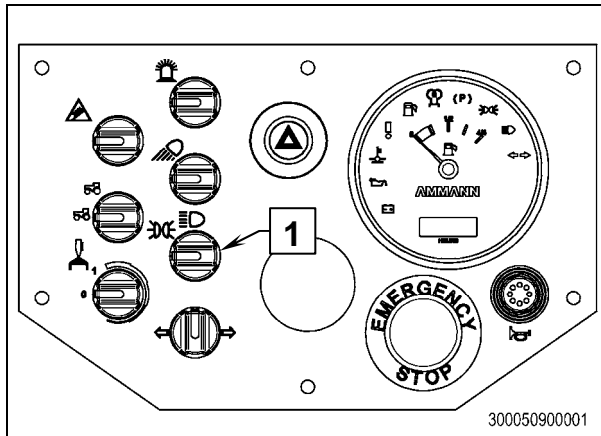

Parking light

Put the ignition into Parking position "P". Then turn the light switch (1) clockwise to the first position.

Dipped light

Turn the ignition key to position I (ignition on). Then turn the light switch (1) clockwise to the second position.

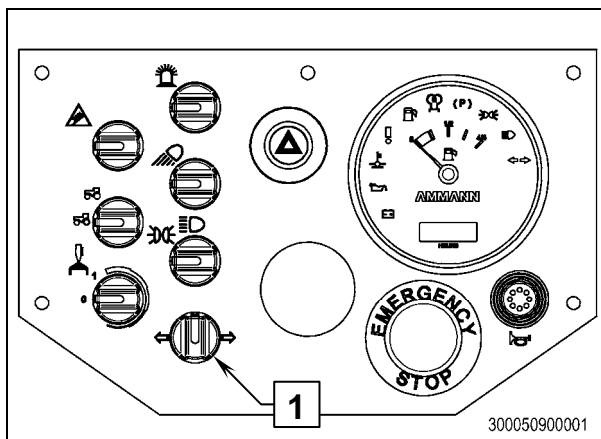

Left indicator

Turn the switch (1) counter-clockwise to turn on the left indicator.

Right indicator

Turn the switch (1) clockwise to turn on the right indicator.

Turn the switch (1) to center position to switch the indicator off.

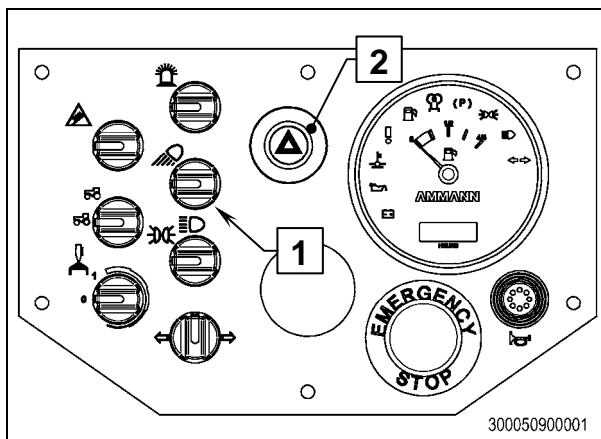

Rear work light

Turn the switch (1) to switch the work light on and off.

Hazard warning light

To switch the hazard warning light on and off press the button (2).



NOTE

The hazard warning light can be switched on and off independently of the ignition key position.

Interval sprinkler

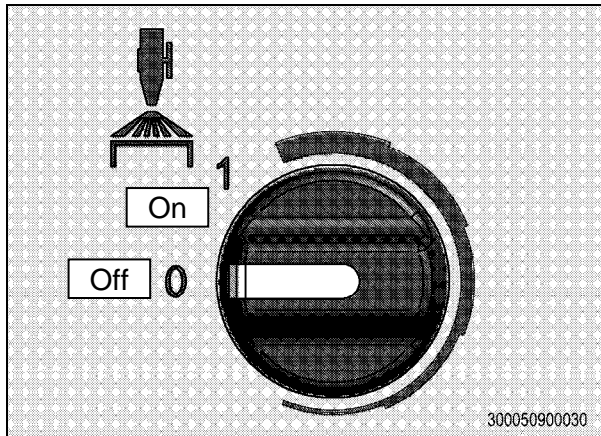

Switching continuous sprinkling on and off

Turn the sprinkler switch from position 0 to position 1 to activate continuous sprinkling.

Interval sprinkler

Turn the switch further right to switch on interval sprinkling.

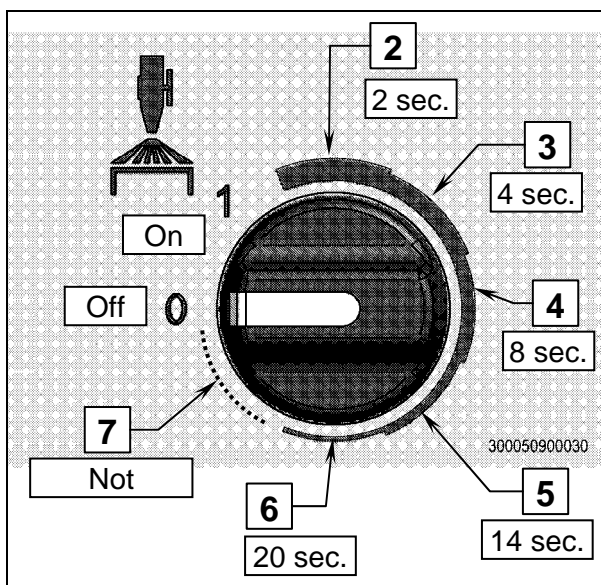

Interval sprinkler pause times

Turn the switch gradually to the right to change the duration of sprinkling pauses step by step.

Pos. 0	Off
Pos. 1	Continuous sprinkling
Pos. 2	2 seconds
Pos. 3	4 seconds
Pos. 4	8 seconds
Pos. 5	14 seconds
Pos. 6	20 seconds
Pos. 7	Not assigned



NOTE

(Nothing happens in position 7. This is the same condition as when the switch is in position 0 [off]).



ATTENTION!

Machine damage!

If your machine is not equipped with an interval sprinkler avoid turning the switch too far to the right. In this case you can only select positions 0 and 1.

Delayed seat contact

Seat contact switch with delay

If the driver stands up braking is delayed.

This means that as soon as the driver gets up off the seat, an acoustic signal is given for two seconds before the machine automatically comes to a standstill.

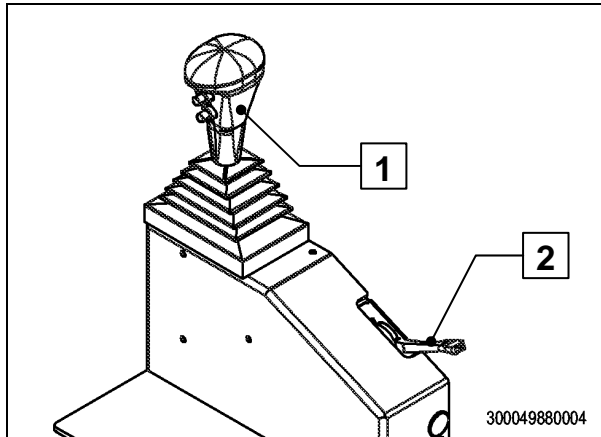

Restarting the roller

First move the operating lever **(1)** to neutral position.

You can leave the speed adjusting lever **(2)** in its previous position.

You can now start the roller by moving the operating lever **(1)**.



NOTE

If the driver sits down again within two seconds the roller continues to drive.

Anti-adhesive

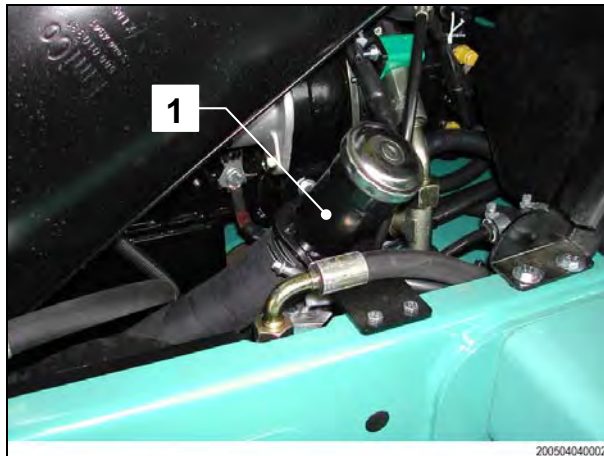

Position of anti-adhesive tank

The anti-adhesive tank filler neck (1) is located below the hood at the right of the roller.

Anti-adhesive reservoir volume: 14 l

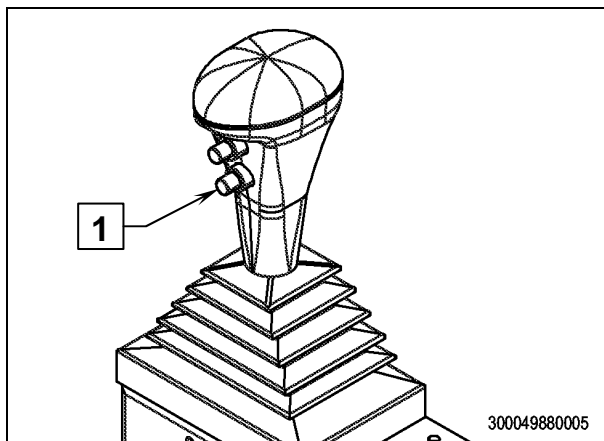

Activating anti-adhesive

If the roller is equipped with the anti-adhesive option, you can activate anti-adhesive with the lower button (1) on the operating lever.

Anti-adhesive is admixed until you release the button.

Anti-adhesive is a water-soluble specialized liquid for combined rollers. The anti-adhesive ensures effective separation between the pneumatic surfaces and the bitumen course.

Advantages of anti-adhesive:

- No tearing of the course thanks to the good separating effect.
- Extremely low anti-adhesive consumption.
- The course can be worked at higher temperatures.
- Less shock to the hot course due to lower water consumption.
- Anti-adhesive does not corrode the pneumatic tire rubber.
- Penetration of superfluous anti-adhesive has no subsequent negative effects.
- The anti-adhesive is biodegradable.

Anti-adhesive designations

Anti-adhesive designations

Manufacturer	RHODORSIL
Description	RHODORSIL EMULSION E1P
Quantity	25 kg
Mixing ratio	1,5 : 100
Part number	1-951318

1-point lifting eye

If your roller is fitted with this option, you can lift the machine for transport using the 1-point lifting eye as an alternative to the 4-point lifting eyes.

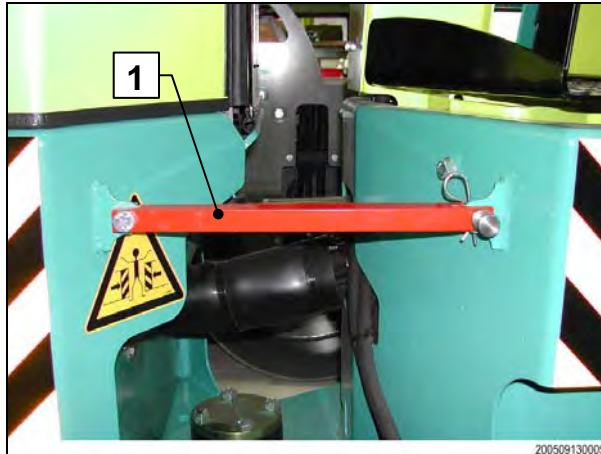

Articulated joint lock

WARNING!

Danger of crushing!

Before lifting, during transport of the machine, you must install the lock (1) of the articulated joint (joint protection).



Lifting at the 1-point lifting eye

WARNING!

Accident hazard!

- Always lift the machine vertically.
- Personnel are not allowed below suspended loads!
- Use only anti-slip, sturdy ramps when loading!
- Secure the machine on the transport vehicle to prevent it rolling, slipping sideways or overturning!



NOTE

The lifting devices (steel cables, etc.) must be dimensioned in accordance with relevant regulations.

Automatic vibration

In automatic mode vibration is switched on at speeds greater than 1-2 km/h and off at speeds less than 1-2 km/h.

Vibration is not possible with the roller at a standstill.

WARNING

Unintentional reaction / accident hazard

If the automatic vibration pre-select switch is set to automatic and vibration is activated, the roller begins to vibrate as soon as the operating lever is pushed forwards.

If the driver is surprised by this reaction an uncontrolled and hazardous action may result.

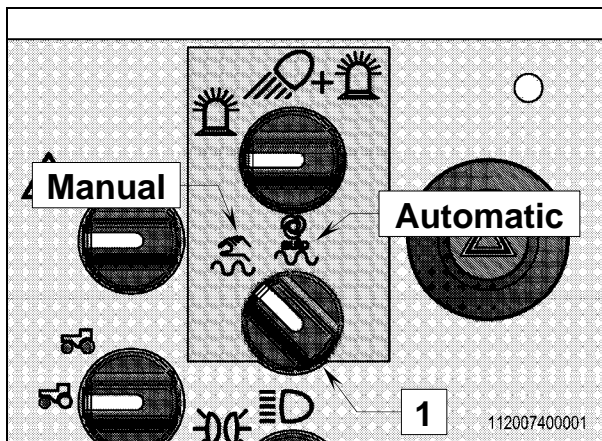

Manual vibration

Set the pre-select switch **(1)** to the Manual position.
The roller vibrates as soon as the vibration button **(2)** on the operating lever is pressed.

Automatic vibration

Set the pre-select switch **(1)** to the Auto position.
The roller vibrates as soon as vibration is activated and the roller reaches a speed of 1-2 km/hr.

Because the operating lever deflection angle starts vibration, slower deflection of the operating lever is necessary for correct functioning.

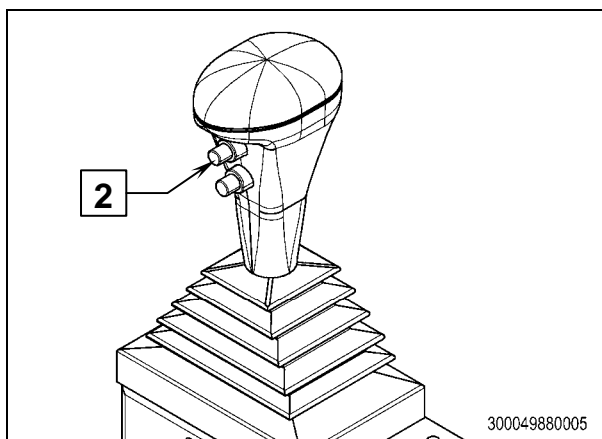

Automatic vibration

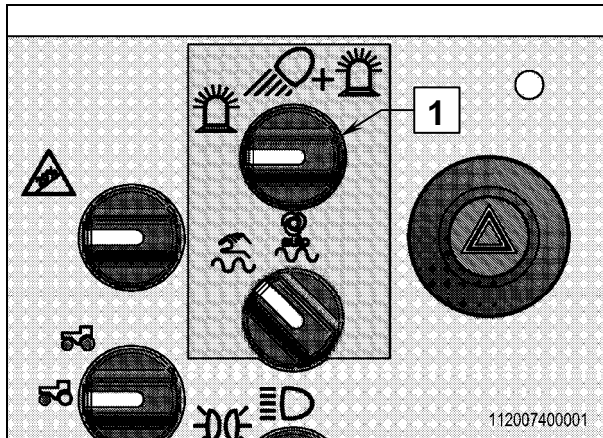

Rear work light

Turn the switch **(1)** clockwise to the first position to switch the rear work light on and off.



Rear work light and revolving warning light

Turn the switch **(1)** clockwise to the second position to switch the rear work light on and off.



NOTE

If the roller is no longer fitted with a revolving warning light, only the work light is lit.

Seat heating

The seat heater warms the seat to body temperature.

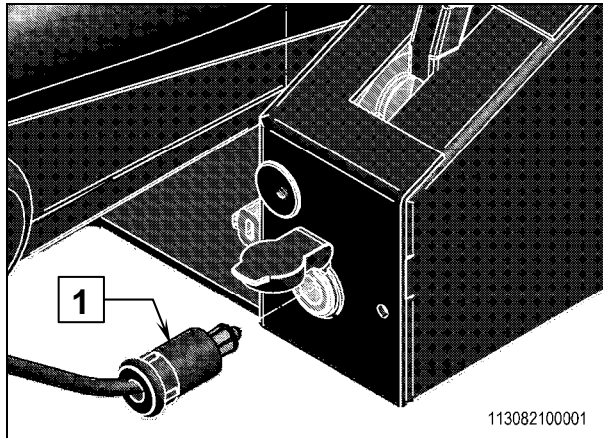

Switching on seat heating

Switch on the seat heating by inserting the plug (1) in the rear of the operating lever console.

The seat heating only works if the ignition key is at position I, II or III.



NOTE

Extended use of the seat heater with the key at position I may drain the battery.

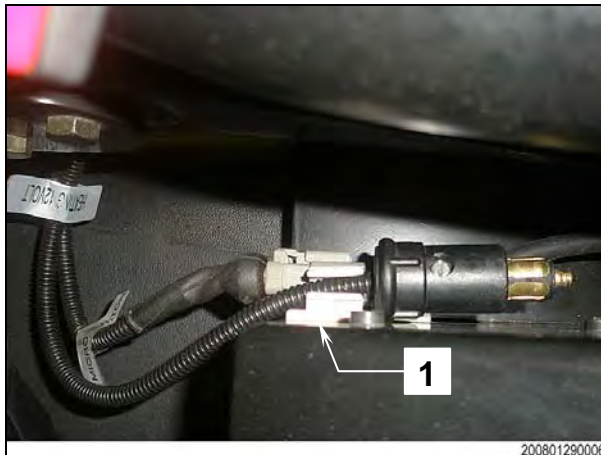

Plug storage

When the seat heating is not being used the cable and plug can be stowed behind the operating lever console.

Put the cable in the clamp (1).

ROPS2D

The ROPS2D option is an early warning and functions management system for reducing the rollover risk.



WARNING!

ROPS2D does not replace the rollover bar. The ROPS must be raised during operation.



WARNING!

ROPS2D cannot prevent machine rollover; the purpose of the protection system is to reduce the rollover risk. In combination with operator training, this system will help to make machine rollover less common.

The ROPS2D for reducing rollover risk is a two-stage system:

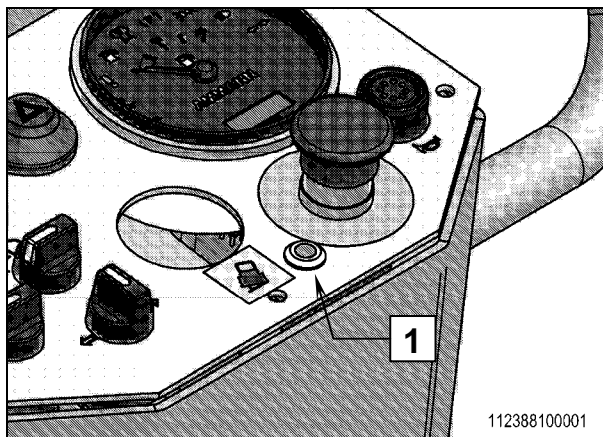

STAGE 1

By means of a red warning light (1) on the instrument panel and an acoustic alarm in the driver's area, ROPS2D warns the operator that the roller has reached a working angle presenting a possible hazard.



NOTE

Only the angle of the front roller drum transverse to the direction of travel is measured.

STAGE 2

ROPS2D switches vibration off if the working angle increases or a critical situation occurs. This happens in order to reduce the risks of edge failure, lateral drifting or unexperienced operating personnel.

ROPS2D



NOTE

The vibration system remains switched off until the roller returns to a safe working angle. Only then can the vibration be switched on again.

Daily inspection:

Turn the ignition key from 0 to 1. If a short beep is heard, the system is ready.

Monthly inspection:

ROPS2D must also be tested in the course of the monthly inspection. Carry out the ROPS2D test according to the following procedure.

Skewing the front roller drum

1. Ensure that the roller is on level ground.
2. Set the engine speed to operating speed.
3. Switch vibration on → Vibration running = OK.
4. Switch vibration off.

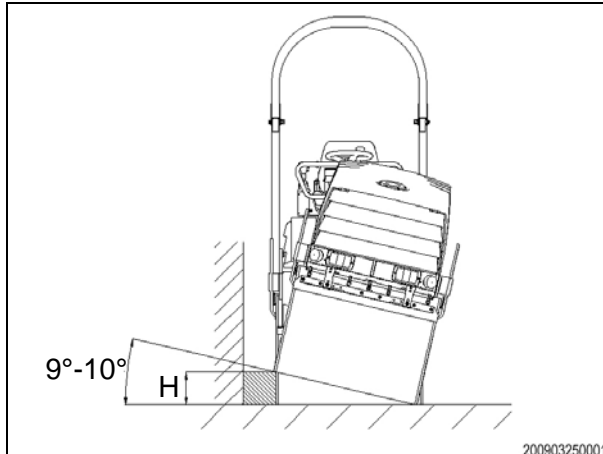

5. With the front wheel of the roller only, drive the side edge of the roller drum onto a solid, secure object with the following height H:

AV 23-2/K	= 17 cm
AV 26-2/K, 32-2/K	= 21 cm
AV 33-2, 40-2/K	= 23 cm

This gives an angle for the front wheel of approx. 9-10°.

6. After two seconds the red warning light lights up and the acoustic alarm is activated.
7. Try to switch vibration on. It should **NOT** start.
8. ROPS2D and the roller are ready.

8 Maintenance

Important notes



 **ATTENTION!**

Damage to electrical controls!

Never spray the water jet into electrical or electronic components.

Never spray into the engine combustion air intake.



 **ATTENTION!**

Damage to electrical controls!

Disconnect the battery when doing welding work on the machine!



 **ATTENTION!**

Hydraulic control failure!

Hydraulic tubes decompose.

It is forbidden to change used machines for use with biodegradable hydraulic oils!

If hydraulic hoses on a machine running on synthetic ester HE need replacing, only those declared by the supplier as being compatible with synthetic esters may be used.

Roller maintenance



ATTENTION!

Not all maintenance tasks are listed in these operating and maintenance instructions. With regard to the Yanmar engine, please observe the maintenance table on the following page! We would also like to point out the separate manual for the Yanmar engine.



NOTE

Maintenance may only be carried out by trained specialized personnel!

- When carrying out maintenance work always observe the applicable safety regulations in the Safety section.
- Maintenance work and inspections must be performed according to the following maintenance tables in order to guarantee reliable machine operation. The individual points are described in detail on the following pages.
- Remove all dirt before taking off any covers, plugs, measuring rods, etc. to inspect or top up engine oil, hydraulic oil, diesel or other liquids.
- Any parts that do not pass the following inspections must be replaced immediately.
- The protective devices must be correctly refitted after every service.

Every 10 operating hours (daily)

- Inspect engine oil level.
- Inspect coolant.
- Inspect fuel level and fill up tank.
- Inspect hydraulic oil level.
- Inspect sprinkler system.
- Inspect scrapers, adjust or replace if necessary
- Inspect condition of roller drums
- Check that the tire pressure on the pneumatic wheel axis is 2.5 bar

Roller maintenance

- Visual inspection for leaks, loose bolts, etc., on the entire roller.
- Drain the sprinkler system and unscrew the water filter if there is a risk of frost or protect by adding anti-freeze
- Check correct functioning of the lighting system if the machine is fitted with the lighting or revolving warning light options.
- Clean the machine if badly soiled. (remove coarse soiling on the oil cooler and radiator grill).
- Fold down the vandalism protection.

Every 50 operating hours (weekly)

- Check air filter cartridge, clean if necessary.
- Inspect operation of seat switch and emergency-stop
- Lubricate steering cylinder bearing (bearings are maintenance-free, depending on design).

Every 500 operating hours (or at least annually)

- Hydraulic oil change and filter replacement:
First hydraulic oil change after 500 hrs., then every 1,000 hrs., but at least annually.
This service can only be completed by a skilled tradesman and is described in the workshop manual.

Every 1,000 operating hours (or at least annually)

- Inspect gas pressure dampers, hood must stay in the open position. The spring tension decreases at low temperatures.
- Inspect soundproofing, there should be no gap between hood and chassis.
- Inspect rubber elements for cracks and brittle surfaces.
- Inspect hydraulic hoses for cracks and wear of the rubber protecting layer.
- Inspect liquid containers for leaks (water, coolant, hydraulic, engine oil and fuel tanks).
- Check the emergency stop function.
- Carry out a brake test.
- Check battery charge.

Roller maintenance

Every 3,000 operating hours

This service can only be completed by a skilled tradesman and is described in the workshop manual:

- Replace the rubber elements (every 3,000 hrs or every 5 years)
- Roller drum servicing: inspect vibration bearing, bearing grease and protective shaft sleeve.

Yanmar engine maintenance

Regular checks and minor service

System	Inspection item	Daily	Regular inspection interval		
			Every 50 hrs.	Every 250 hrs.	Every 500 hrs.
Fuel	Check and top-up the level in the (diesel oil) fuel tank	○			
	Drain water from fuel tank		○*		
	Drain water from the oil/water separator		○		
	Clean oil/water separator			○	
	Replace fuel filter				⊙
Engine oil	Engine oil level	○			
	Replace engine oil		⊙*		⊙**
	Replace engine oil filter		⊙*	⊙**	
Coolant	Check and top-up coolant	○			
	Check and clean radiator			○	
	Check and adjust fan belt		○*	○**	
	Check and adjust operating lever and gas lever	○		○	
Inlet & outlet	Clean and replace air filter element			○	⊙
Elec. system	Check control lamps	○			
	Check and recharge battery electrolyte		○		

○ Check, ⊙ Replace

* 1. time

** 2. and subsequent times

Yanmar engine maintenance



NOTE

The following maintenance tasks must be performed by your authorized Yanmar dealer:

Major service

System	Inspection item	Regular inspection interval	
		Every 1000 hrs. or once a year	Every 2000 hrs. or every 2 years
Coolant	Flush and service coolant system		⊙
	Replace coolant	⊙	
	Check or replace fuel and coolant hose		○ or ⊙
Cylinder head	Adjust inlet/outlet valve play, IN 0.2 mm / OUT 0.2 mm	○	
Fuel valve, pump	Inspect and adjust the fuel injection nozzle pressures	○	
	Inspect and adjust the fuel injection pump		○

○ Check, ⊙ Replace

Please also observe the Yanmar engine operating instructions and the detailed instructions given there.

Towing, releasing brakes

Only tow the machine in an emergency in order to remove the machine away from the danger zone.



CAUTION!

Maximum towing speed: 1km/h
Maximum towing distance: 10m

Then transport the roller by truck or trailer.

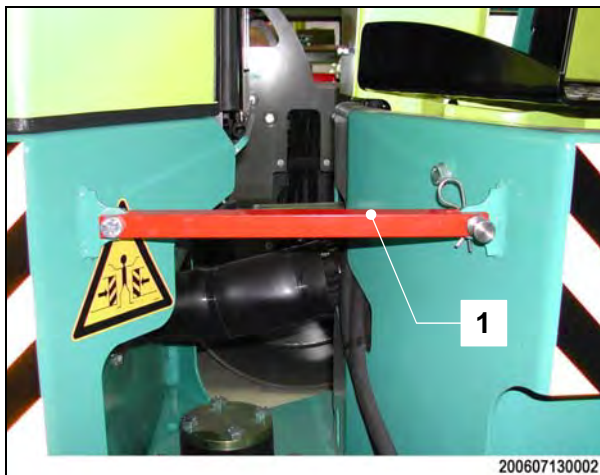

Articulated joint lock

Secure the machine with the joint protection (1).

Releasing brakes

Before you can tow the machine you must release the integrated parking brake.



WARNING!

Roll-over hazard!

Before you can release the brakes it is essential to secure the machine from unintentionally rolling away.

Towing, releasing brakes

Drive motor MS02

(AV23-2, AV26-2, AV32-2)

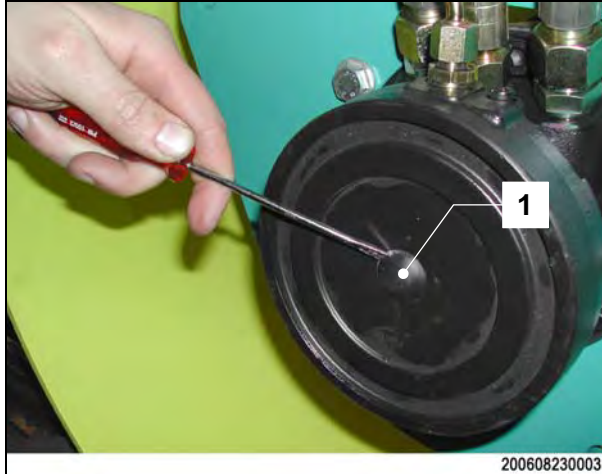

Remove the protective cap **(1)** on the front and rear drive motor.

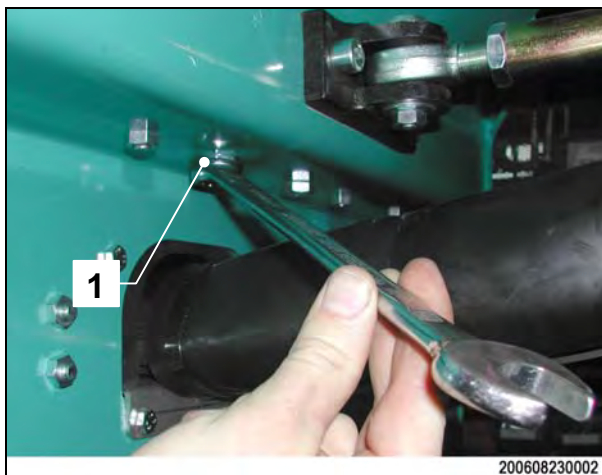

You can find the brake release chocks in the front chassis under the hood.

The brake release chock is fastened under the hood by two screws M12 x 35 **(1)**.

Unscrew the screws using a wrench and remove the brake release chock.

The two screws also act as tension screws.

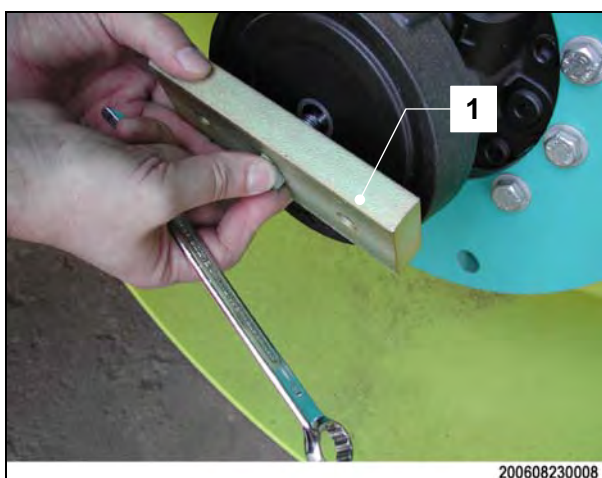

Screw the brake release chock **(1)** onto the drive motor.

Turn the screw in by hand.

Towing, releasing brakes



Turn the wrench approx. one half turn downward.



Wrench rotation on the motor approx. 180°.

The brakes have been released, you can now tow the machine.

Drive motor MK04

(AV33-2, AV40-2, AV23-2 open-sided, AV26-2 open-sided)



Remove the two cover screws **(1)** on the drive motor with an Allen key (SW8).

Towing, releasing brakes

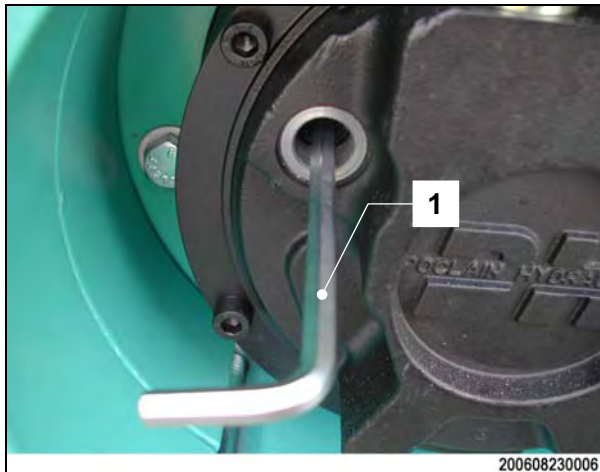

You can now see two other Allen screws.

Press these screws in and tighten them alternately and in stages with an Allen key **(1)** until they are tight.

The brakes have been released, you can now tow the machine.



Towing hook

Tow the machine by attaching the towing equipment (steel rope, etc.) to the towing hook provided **(1)**.

Opening the hood

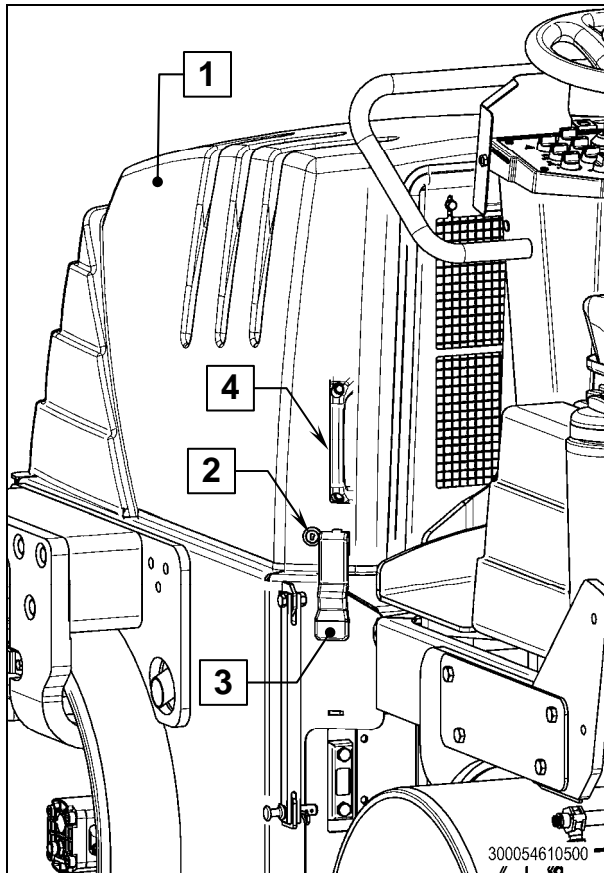

Unlocking the hood (1)

The hood lock (2) is located on the left-hand side. Use the ignition key, turned a quarter-turn clockwise, to open the lock.

Open the hood

There is one locking device (3) on the left and one on the right of the roller.

You must release both locks in order to lift the hood.

Lifting the hood

Open the hood with the handle (4) on the left of the hood.

Lift the hood with slight pressure toward the center of the roller and then open the hood completely.

If the hood is defective, replace it immediately.



NOTE

Two gas absorbers reduce the force required to open the hood and give it its final position. If you need more force to open the hood, replace the gas absorbers.



WARNING!

Burns hazard!

- Only work on a cool engine.
- Keep enough distance to the exhaust.

Opening the hood



 **WARNING!**

Trapping hazard!

Only open the engine hood when the engine is switched off.

If it is absolutely necessary to work on moving parts (engine or machine) for troubleshooting, never wear necklaces, bracelets, scarves, ties or other loose clothing. If any of these get caught in moving parts there is a danger of serious injury!

Engine compartment inspection summary



WARNING!

Switch the diesel engine off when performing any inspection, adjustment or maintenance work. The parking brake is active when the diesel engine is switched off.

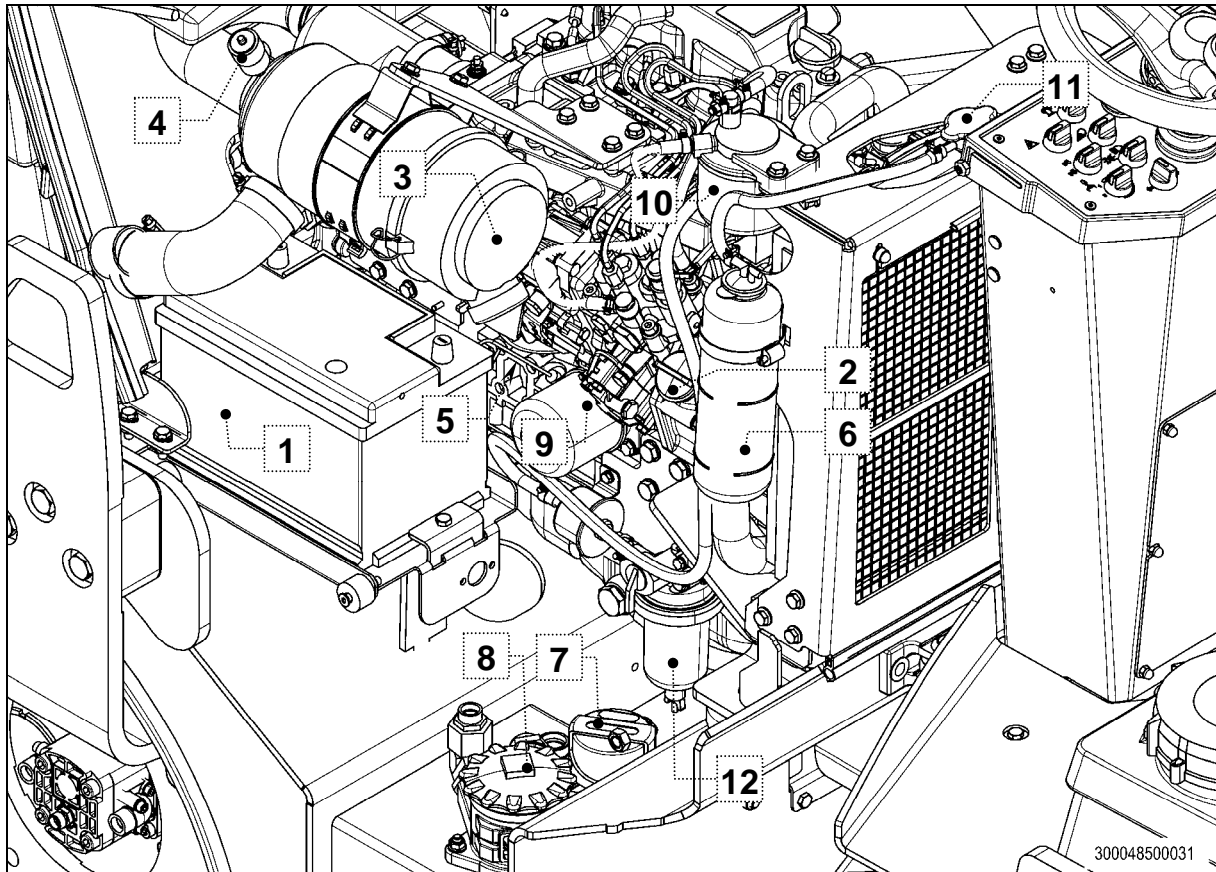

- 1 Battery
- 2 Engine oil filler neck
- 3 Air filter
- 4 Air filter soiling display
- 5 Oil dipstick
- 6 Coolant level display
- 7 Hydraulic oil filler neck
- 8 Hydraulic oil filter
- 9 Engine oil filter
- 10 Fuel filter
- 11 Coolant filler neck
- 12 Water separator

Inspect – engine oil level, coolant level

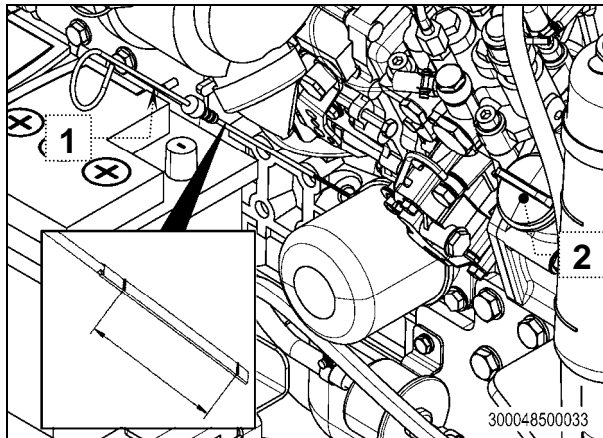

Checking engine oil level

Use the dipstick to check engine oil level every day.

The dipstick (1) is located on the left of the engine.

Check oil level while the roller is standing on a level surface and the engine is cold.

The oil level must be between the upper and the lower mark.

Top up the engine oil as required (2).



NOTE

In order to ensure long term engine operating safety, no additives may be used in the engine oil.

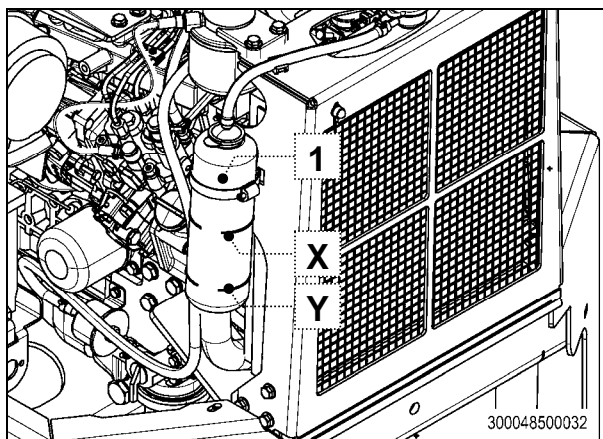

Checking coolant level

Check the coolant level (1) daily.

Check oil level while the roller is standing on a level surface and the engine is cold.

The coolant level is visible on the expansion tank display.

The water level must lie between the top (X) and the bottom marks (Y).

Top up coolant as required (1).

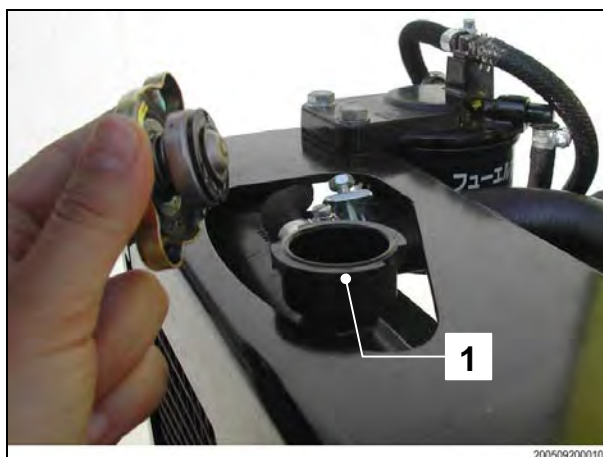

Warning

Danger of burns!

Only open if the engine and coolant have cooled down.

Inspect – fuel level, hydraulic oil level



WARNING!

Danger of roll-over!

Switch off the diesel engine to avoid unintentional start-up of the machine.



Fuel tank - filling

Fill the fuel tank with fuel oil up to the lower edge of the filler neck **(1)** every day before starting work.

The tank holds 43 l of fuel.

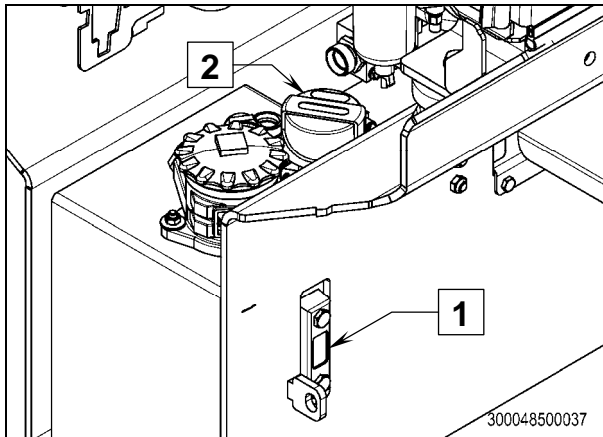

Hydraulic oil tank - checking oil level

Drive the roller onto a level surface - and check the oil level in the inspection window **(1)**.

If oil level is 20 mm below the top edge of the inspection window, top up hydraulic oil through the filler neck **(2)**.



NOTE

Pay attention to the lubricant table.

Checks – sprinkler system, scraper



Check and adjust the sprinkler

Switch the sprinkler on and check the nozzles **(1)** on the front and rear sprinkler pipes.

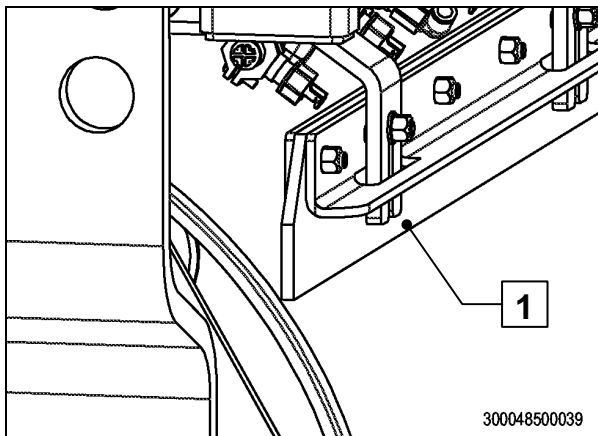

Check and adjust scrapers for the roller drum

Pre-tension the scrapers **(1)** lightly by hand.

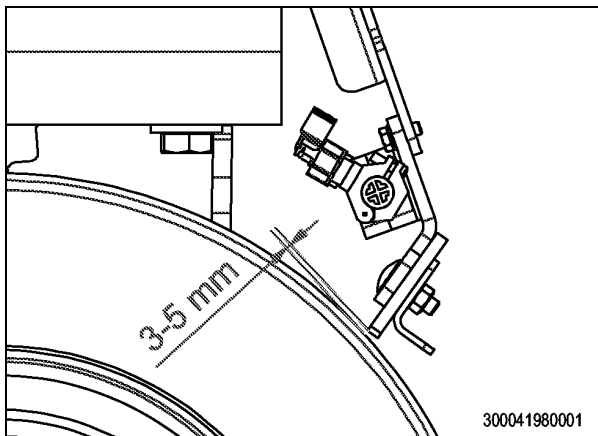

Check and adjust scrapers for the pneumatic wheel axis

Adjust the scrapers with a clearance of 3-5 mm.

The anti-adhesive must not get scraped off.

Checks – tire pressure

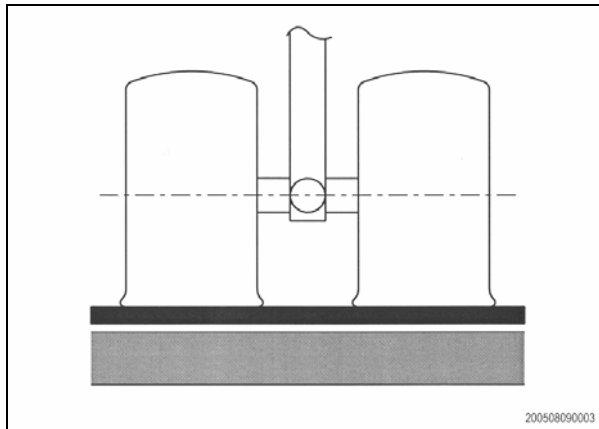

Check and adjust tire pressure on the pneumatic wheel axis

Tire pressure OK => 2 – 2.5 bar

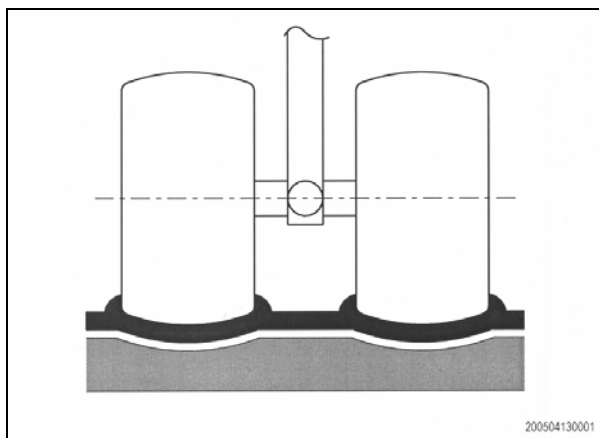

Tire pressure too high =>
Reduce pressure by letting out some air.

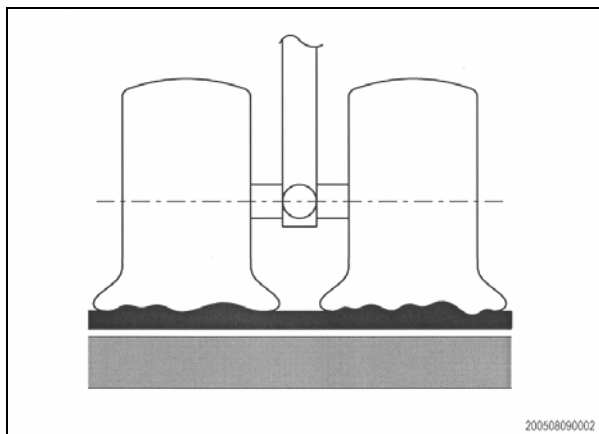

Tire pressure too low =>
Increase pressure by pumping in some air.

Checks – air filter cartridges



Dirt outlet

Press the dirt outlet **(1)** of the air filter at least once a week to clean it of dirt.

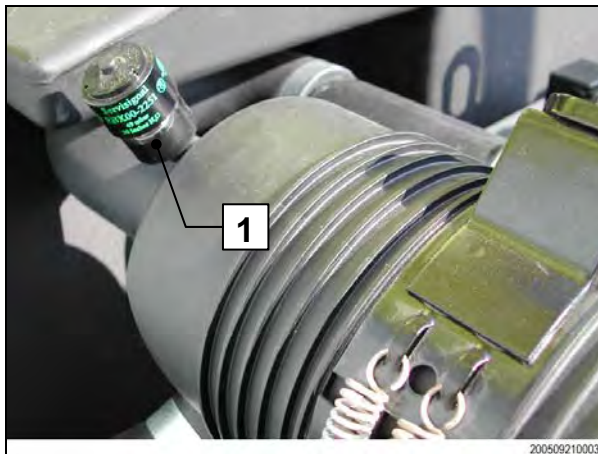

Soiling indicator

If a red ring appears on the soiling display **(1)** during operation of the roller, you must clean or replace the air filter cartridge.

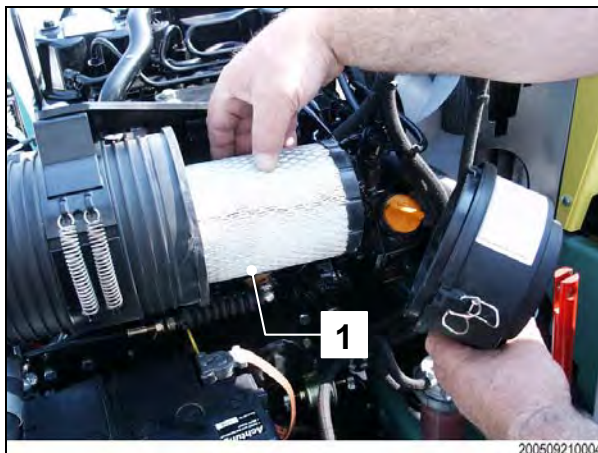

Air filter cartridge

Check the air filter cartridge **(1)** for damage or soiling.

Clean the cartridge if necessary.

Checks – Seat contact and emergency stop

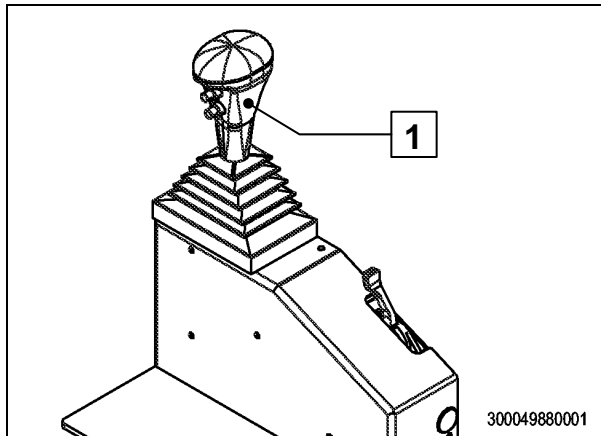

Move the drive lever **(1)** to zero position.

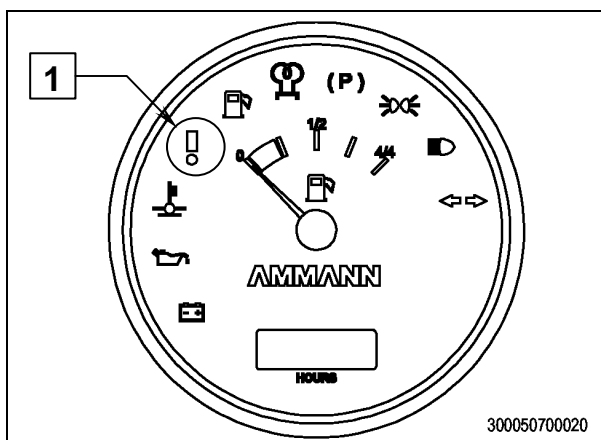

Sit on the driver's seat and start the engine.

The control lamp for emergency stop circuit, operating lever neutral position and seat switch **(1)** must extinguish immediately.

Leave the seat.

After 0.7 seconds the control lamp for the emergency stop circuit, operating lever neutral position and seat contact **(1)** light up.

Switch off the engine.



NOTE

The control lamp for the emergency stop circuit, operating lever neutral position and seat contact must extinguish after 2 seconds for delayed seat contact.

Inspect – brakes (brake test)



Remove the brake hose (1) from the front roller drum front drive motor.



Seal the open hose end so that it can be pressurized.

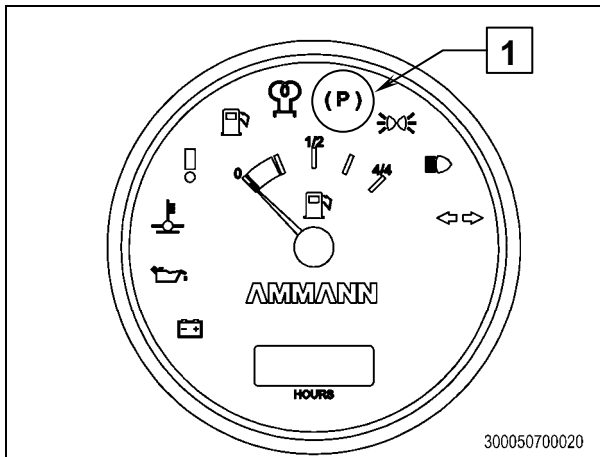

Start the machine. The brake light (P) (1) must extinguish quickly. Test the forwards and the backwards drive.

Because the front brake remains activated, the machine does not move.

Turn the machine off and refit the brake hose.

Follow the same procedure for the rear drive motor.

Inspect – brakes (brake test)

Once you have completed the front and rear brake tests, ensure that all brake hoses are reconnected! Start the machine; the brake light (P) must extinguish quickly. Test the forwards and the backwards drive. There should be no problems.



ATTENTION!

If the machine does not behave exactly as described, you have a problem with one or more brakes. The roller is no longer safe to operate and must not be used until properly repaired!

Pneumatic wheel axle

If you own a machine with a pneumatic wheel axle, it is better to remove the center wheels. Please examine both motors simultaneously.

Lubricate steering cylinder bearing

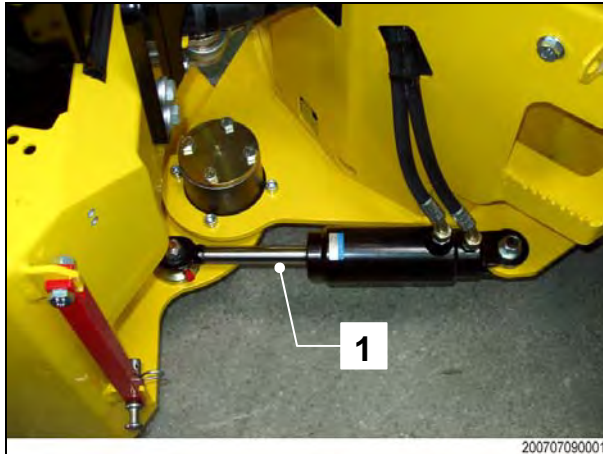

Rotate the steering to the stop to grease the cylinder.

The cylinder bearing (1) must first be relaxed. Turn the steering briefly to the right and the left.

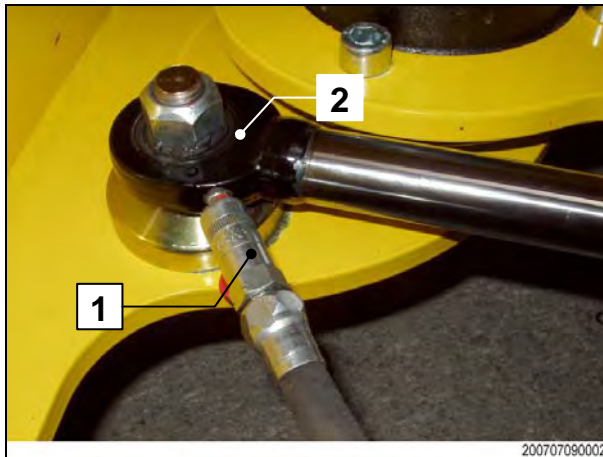

Clean the grease nipple before greasing.

Attach the grease gun (1) to the grease nipple and press grease in until it visibly exits the bearing (2).

 **ATTENTION!**

Material damage

The steering cylinder bearing should be regreased after every machine wash/steam wash.

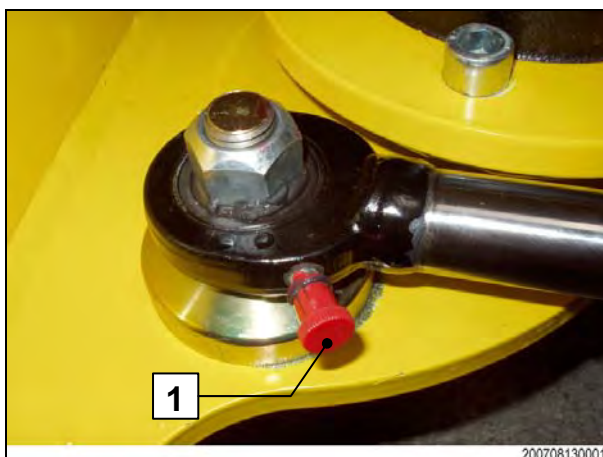

Replace protective cover (1).

Removing the front water tank

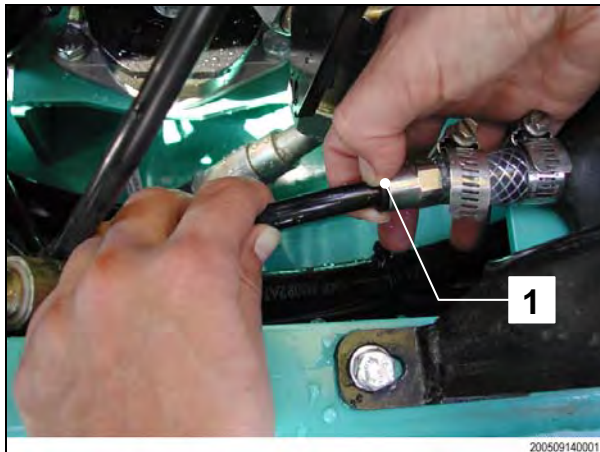

Disconnecting the sprinkler hose

Hold the hose in your left hand and press the black plastic ring **(1)** against the screw connections with your right hand.

You can now disconnect the hose.

ATTENTION!

Do not remove the hose without pressing the ring against the screw connection. The hose can get damaged.



Draining water

Now let the water drain off until the tank is completely empty.

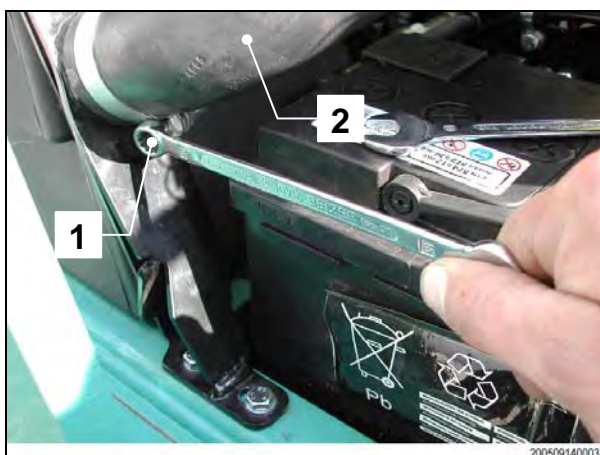

Unscrewing the fastening screws

Unscrew the screw **(1)** of the intake hose clamp **(2)**.

Removing the front water tank

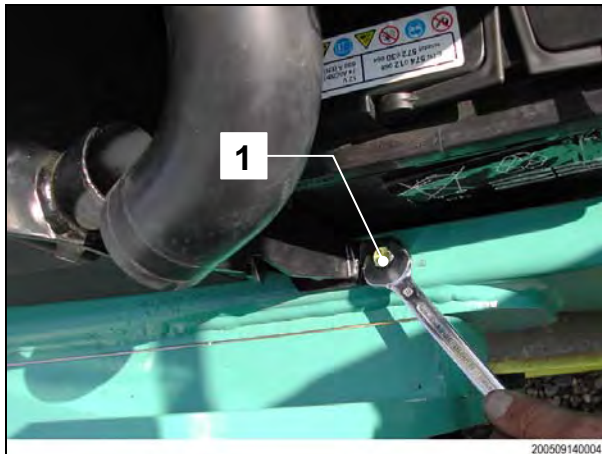

Unscrew the hood holder screws **(1)** on both sides of the roller.

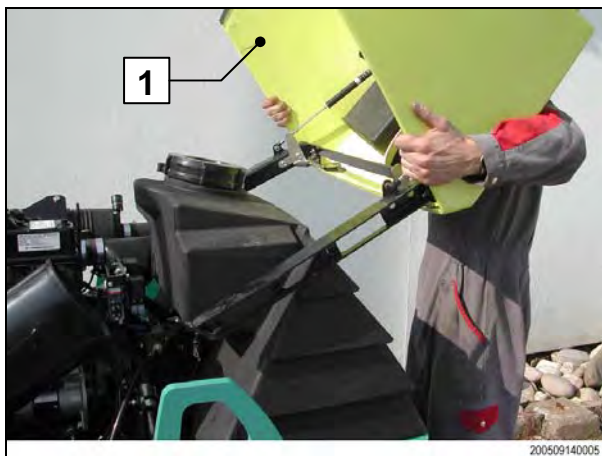

Lifting the hood off

You can now lift the hood **(1)** off with both hands.

Carefully lay the hood down to the side.



Lifting off the water tank

Tilt the tank **(1)** forward slightly toward your chest and lift it off from front to back.

Carefully lay the water tank down to the side.

To reinstall the water tank, proceed in the reverse order.

Removing the rear water tank

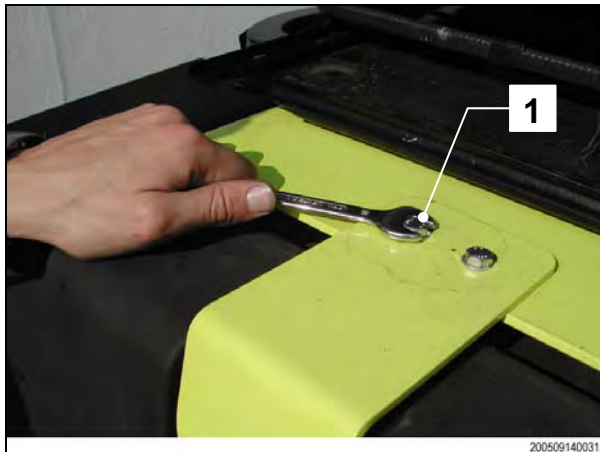

Unscrew the holder screws **(1)**.

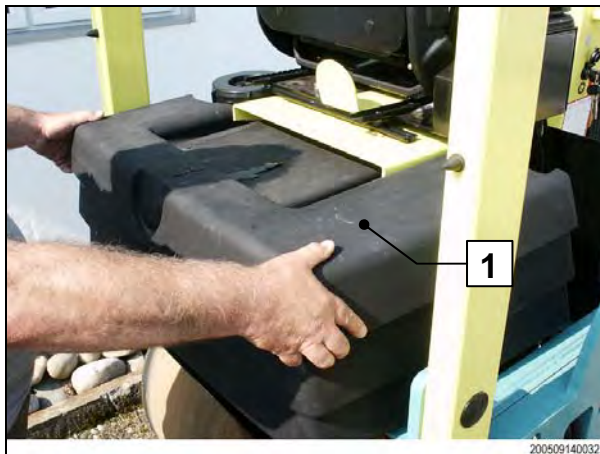

Now pull the tank **(1)** approx. 10 cm to the back.

You can now access the water hose to the left of the seat.

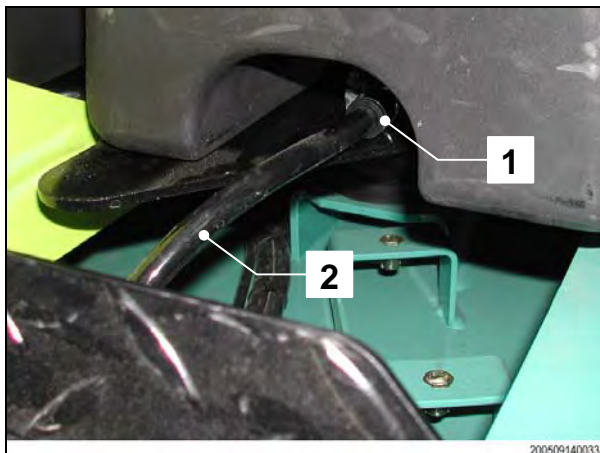

Disconnect the water hose

Unscrew the quick-release **(1)** water hose clamp **(2)** by pressing the black plastic ring against the screw connection. Now pull the hose off the coupling.

You can now pull the water tank all the way out.

Lubricant table

Brand	Hydraulic oil	Synthetic hydraulic oil based on Estern HE	Grease
Standard	ISO VG 46 HVLP DIN 51524 T3	ISO 15380 HEES	ISO 2137 DIN 51502
Application	Drive and vibration hydraulics	Drive and vibration hydraulics	
AGIP	Amica 46		
BLASER	Blasol 148		Foodgrease SPM00 (AV1 vibro bearing)
BP	Bartran HV 46		
CASTROL	Hyspin AWH 46		
ESSO	Univis HP 46		
MOBIL	Mobil DTE15		
MOTOREX	Corex HV 46		Motorex 174 (AV2 drive and vibro bearings)
			MOLY 218 (steering cylinder)
PANOLIN	HLP Universal 46	HLP Synth 46	
SHELL	Tellus T 46		
TOTAL	Equivis ZS 46		

Lubricant table



ATTENTION!

Hydraulic control failure!

Hydraulic hoses and seals decompose.

Only use the listed lubricants as synthetic hydraulic oil and grease.

It is forbidden to change used machines for use with biodegradable hydraulic oils!

Consumables, tightening torques

Consumables

Description	Brand	Quantity	Prod. No.
Engine oil	Motorex Topaz 15W50	1 l	921197
Grease	Motorex Moly 218	400 g	1111368
Grease	Motorex 174	4.5kg	1147048
Grease	Blaser Foodgrease SPM00	14 kg	1075038
Anti-freeze	Motorex green	30 l	922341
Bolt locking	Loctite 243 (blue)	50 ml	907977
Bolt locking	Loctite 243 (blue)	250 ml	907975
Bolt locking	Loctite 262 (red)	50 ml	907978
Bolt locking	Loctite 262 (red)	250 ml	907979
Paint spray	RAL 1016 Sulfur yellow	400 ml	922700
Paint spray	RAL 6033 Mint turquoise	400 ml	922701



CAUTION!

All screws must be secured using Loctite 243/blue (Loctite 262/red for screws or nuts on rubber bearings) unless specified otherwise.

Tightening torques

SW	Bolt diameter	Steel quality	Tightening torque in Nm
10	M6	8.8	10
13	M8	8.8	25
17	M10	8.8	49
19	M12	8.8	86
24	M16	8.8	210
24	M16	10.9	290
30	M20	8.8	410

Replace engine oil

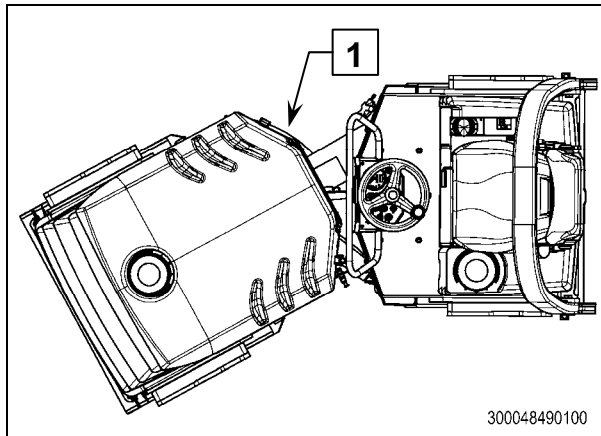

Turn the steering wheel all the way to the left so that you can easily access the engine oil drain **(1)**.

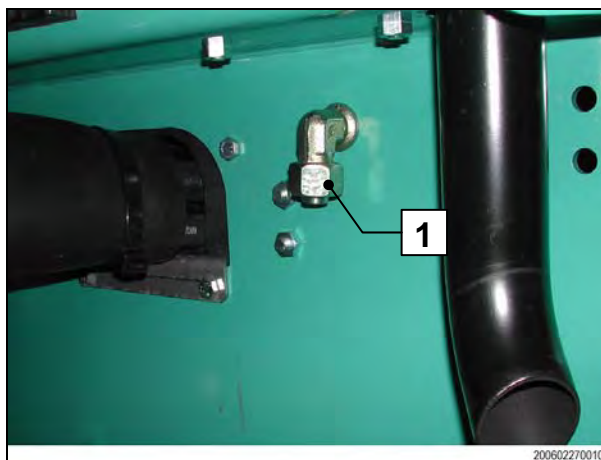

Draining engine oil

The engine oil drain **(1)** is located at the front right, between the front and rear chassis.

Place a container under the drain.

Open the union by turning it anti-clockwise (27 mm wrench). The oil starts to flow out immediately.

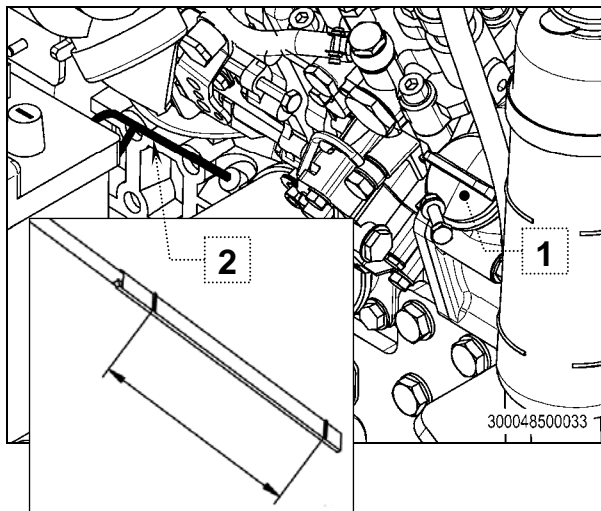

Topping up engine oil

Top up engine oil through the oil filling neck **(1)**.

Check engine oil level

The oil dipstick **(2)** is located on the right of the engine.

Check oil level while the roller is standing on a level surface and the engine is cold.

The oil level must be between the top and bottom marks.

Cleaning

Clean the main soiling from the machine after finishing work.

Regularly clean completely at least once a week. When working on cohesive soils, or with cement and lime stabilizers, clean completely on a daily basis.



WARNING

Only clean the roller when it is static and secured against rolling.



NOTE

- Do not use aggressive or flammable cleansing agents (e.g. gasoline or inflammable substances).
- Only work with the engine turned off.
- Do not directly subject electrical components or isolating materials to a steam jet when using a steam cleaner. Always cover these materials.
- When washing the machine ensure that no water is sprayed into the air - filter.
- Before cleaning the machine with pressure cleaners using water, steam, etc., cover all openings into which the cleaning agent may penetrate. Remove these dummy flanges after cleaning the machine.

9 Tips

Replacing the front bulbs



Removing the light bar

Undo the four screws **(1)** on the light bar and remove them.



Remove the light bar.

The bulbs for the low beam headlights and the parking lights are now accessible.

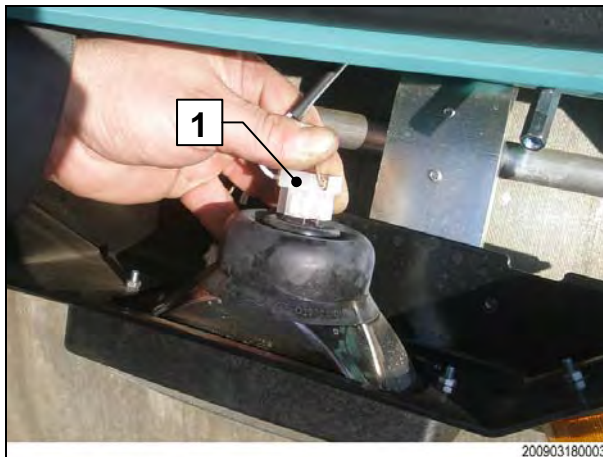

Replacing the low beam headlight bulb

Remove the plug **(1)** from the rear of the lamp unit.

Replacing the front bulbs



Remove the guard (1).



Press on the end of the securing clip (1) to remove it.

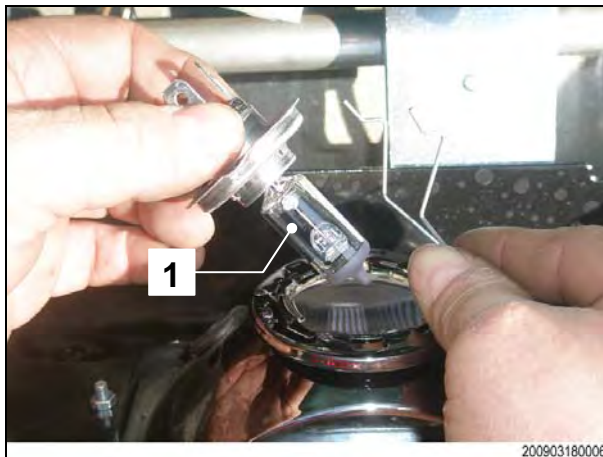

Replace the defective bulb (1) with a new one of the same type and power.

Then replace the guard on the casing.



NOTE

The guard must sit firmly on the glass body of the low beam headlight unit in order to prevent water from entering.

Replacing the front bulbs

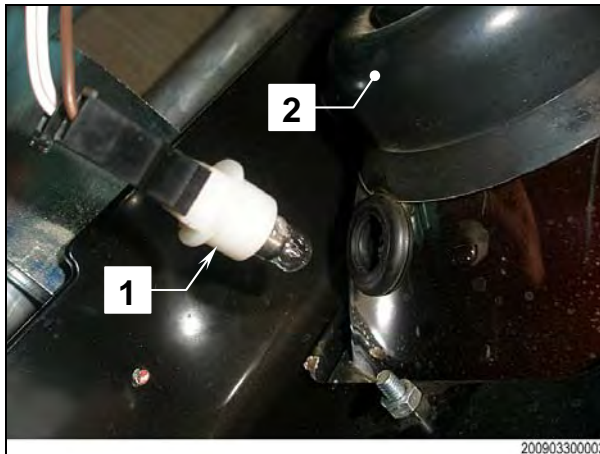

Replacing the parking light bulb

Pull the bulb **(1)** from the lamp holder **(2)** and replace it with a new bulb of the same type and power.



Replacing the side indicator bulb

Undo the screw on the side indicator and remove the indicator glass.

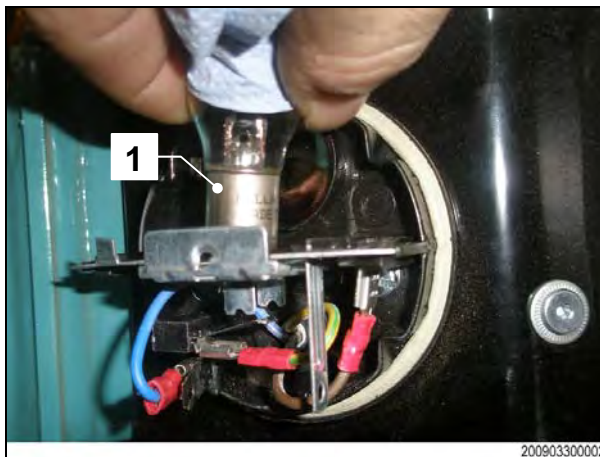

Replace the defective bulb **(1)** with a new one of the same type and power.



NOTE

Do not touch the glass of the new bulb with your fingers. Sweat on your hands can burn into the glass and reduce bulb lifetime.

Engine compartment fuses

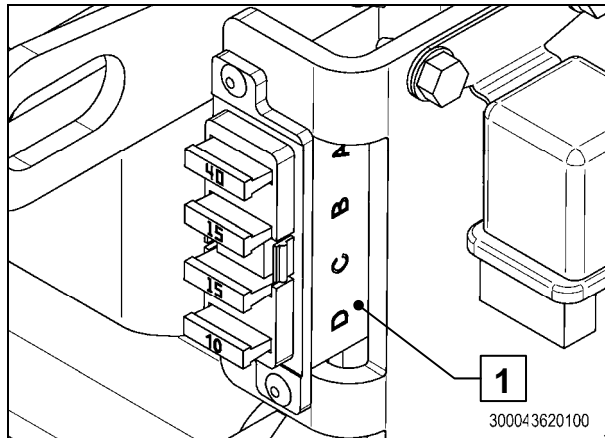

Fuse box in the engine compartment

The fuses **(1)** are located on the right of the engine, at the front between the engine and the water tank.



NOTE

Before replacing the fuse, you must identify and remove the cause of the fault.

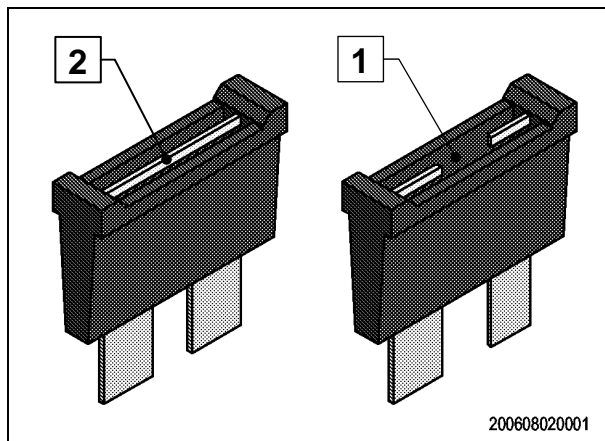

The fuse numbers are indicated on the fuse box.

Always replace a defective fuse **(1)** with a functioning fuse **(2)** of the same amperage (according to the label or color of the fuse).

Fuse No.	Power	Fuse-protected circuit
F11 (A or 1)	40 A	Pull-in solenoid
F12 (B or 2)	15 A	Fan for oil cooler, diesel pump, alternator
F13 (C or 3)	15 A	Reserve (15+)
F14 (D or 4)	10 A	Reserve, not connected



ATTENTION!

Fuses and safety switches must never be shorted.



ATTENTION!

Short-circuit!

Always disconnect the power supply when working on the electrical system.

Steering column fuses

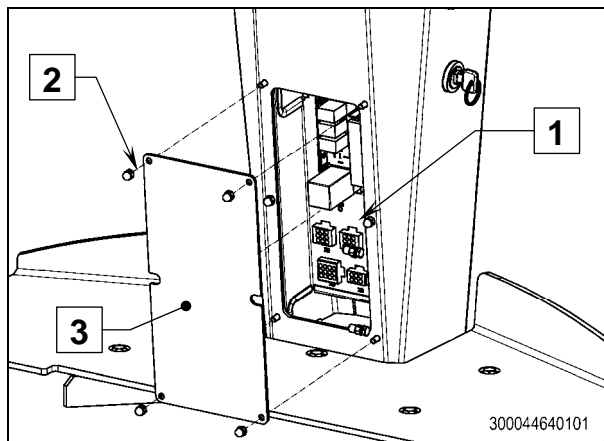

Fuse box (1) in the steering column

Remove the 4 fixing screws (2) and then the cover (3).



NOTE

Before replacing the fuse, you must identify and remove the cause of the fault.

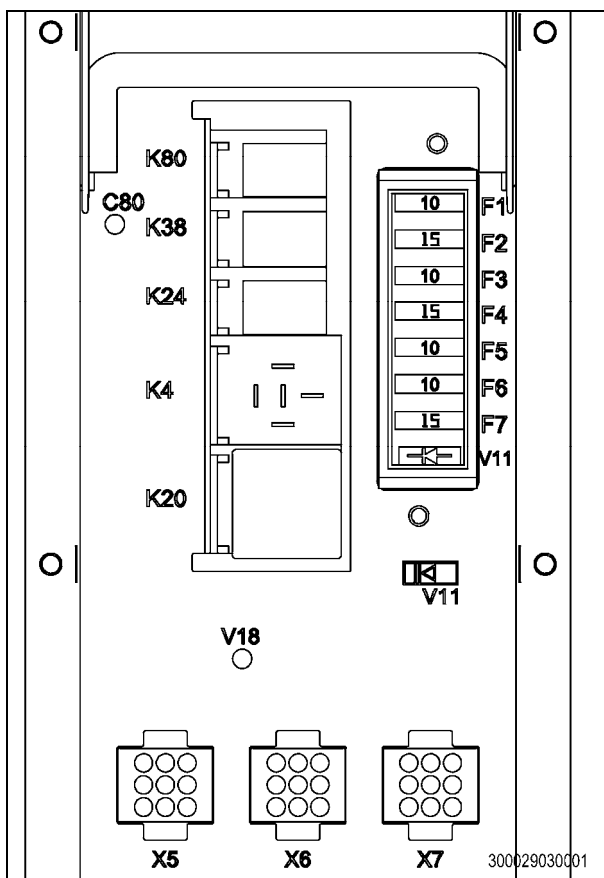

Fuse No.	Power	Fuse-protected circuit
F1	10 A	Parking light
F2	15 A	Dipped light
F3	10 A	Emergency stop, holding solenoid
F4	15 A	Sprinkler, Horn, Reverse alarm, Flow divider,
F5	10 A	Displays, indicators
F6	10 A	Hazard warning light
F7	15 A	Work light, revolving warning light, edge cutter
V11		Diode



ATTENTION!

Install the diode in the correct direction of passage. The ring must be on the left when viewed from above.



ATTENTION!

Fuses and safety switches must never be shorted.

Battery

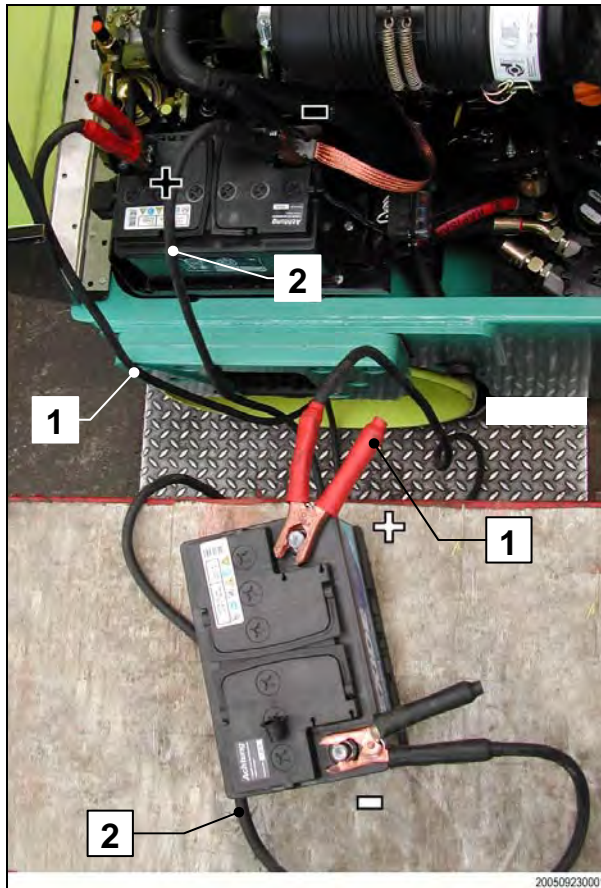

Starting with an external battery

Connect the red cable **(1)** to the (+) terminals of both batteries.

Connect one end of the green or black cable **(2)** to the (-) terminal of the helper battery.

Connect the other end of the green or black cable to a ground point on the roller.

Activate the starter and allow the engine to run.

Wait until the engine is idling smoothly and then disconnect the cable.

Charging the battery using a battery charger:

Disconnect the battery. Observe the battery charger manufacturer's manual.

Start with the (+) terminal when reconnecting the battery.



NOTE

The battery poles and terminals must be clean. If they have a (whitish or greenish) layer of sulfur, you must remove and clean them.

Long-term storage

If the machine is not in operation for more than two days, the battery must be turned off at the cut-off switch. This reduces the risk of battery discharge.

If no battery cut-off switch is fitted to your machine, remove the negative battery cable from the battery if a standstill period of more than two weeks is expected.

10 Storage

Storage

Storage:

- Put the operating lever into neutral position.
- Secure the machine from unauthorized start-up and unintentional rolling away.
- Remove the ignition key.

Long-term storage:

Component	Precautions:
Diesel engine	Observe the information in the "Long-term storage" section in the diesel engine manual.
Diesel	Drain.
Battery cut-off switch	<p>If the machine is not in operation for more than two days, the battery must be turned off at the cut-off switch. This reduces the risk of battery discharge.</p> <p>If no battery cut-off switch is fitted to your machine, remove the negative battery cable from the battery if a standstill period of more than two weeks is expected.</p>
Battery	Uninstall the battery and clean the outside. Charge the battery once a month during standstill time.
Air filter unit, exhaust pipe	Cover the air filter unit or its intake opening and the exhaust pipe with adhesive tape. This prevents moisture from getting into the engine.
Hydraulic oil tank	Drain the hydraulic oil completely. Fill up the hydraulic oil tank with fresh oil when putting the machine back into operation.

Storage

Component	Precautions:
Steering cylinder	Lubricate the bearings of the steering knuckle and the front bearing of the steering cylinder with grease. Lubricate the piston rod of the steering cylinder with grease guard.
Tires	Only combined rollers have tires. Relieve the pressure in tires (pneumatic wheels) if the machine is not being used for a prolonged period by relieving the pneumatic wheel axis with a wooden wedge so as to avoid flat spotting damage to the tires.

Draining the water tank



Cleaning accessories

Clean the following parts as required:

- Water tank with filler strainer (1)

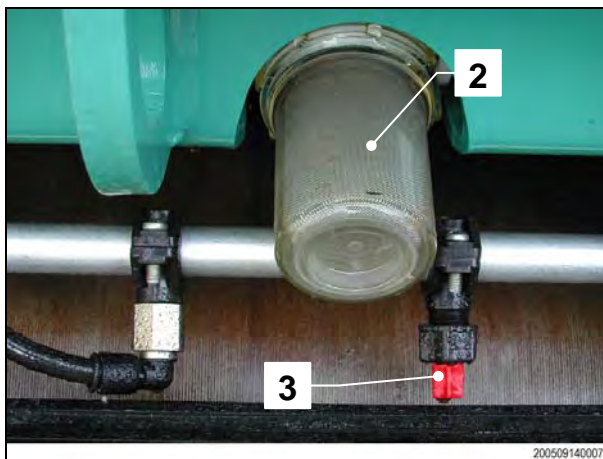

- Water filter (2)
- Sprinkler pipes with nozzles (3)

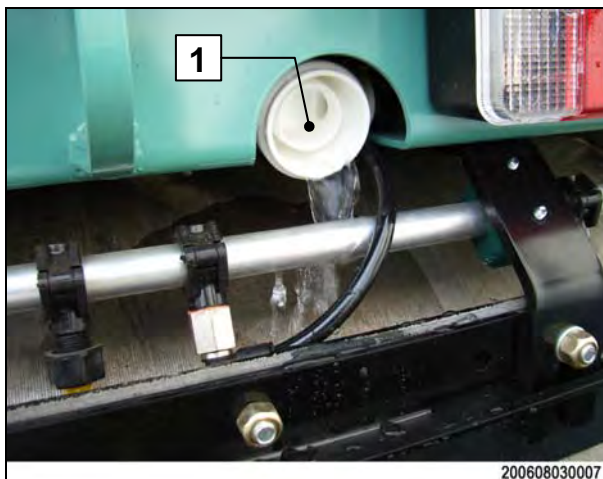

Draining the water tank

Remove the rear water filter (1) and drain off the water.



NOTE

AV2-2: empty the front and rear water tank.



ATTENTION!

Risk of frost!

In the event of the risk of frost, additionally drain the sprinkler system. See next page.

Winterization, emptying the water tank

The purpose of winterization is to guarantee that cold air temperatures below 0° Celsius (-32 F) cannot damage the sprinkler system.

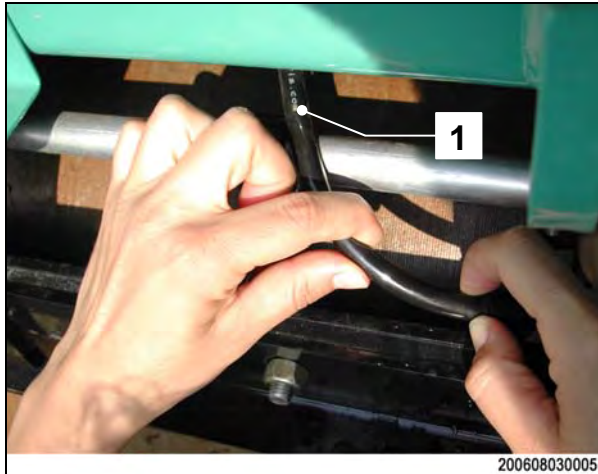

Draining the rear water tank and the sprinkler system

Release the quick-release sprinkler hose coupling **(1)** by pressing the black plastic ring against the union.

Now pull the hose off the coupling.



Drain off the water.



NOTE

AV2-2: empty the front and rear water tank.



Emptying the front water tank

Optionally, to speed up draining and ensure that the tank is completely emptied, you can empty the front water tank separately.

Unscrew the quick-release sprinkler hose clamp **(1)** by pressing the black plastic ring against the screw connection.

Now pull the hose off the coupling. Drain off the water.

Winterization, emptying the water tank

Switch on the sprinkler and let the water pump run briefly. This pumps the remaining water out of the pipes.

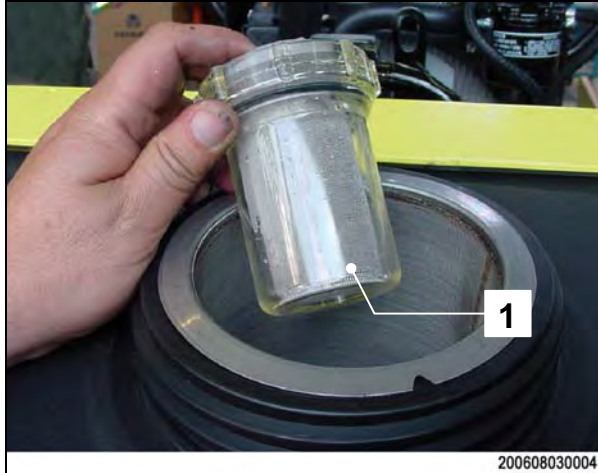

The plastic water filter container **(1)** can be stored on the machine, in the water tank water filter.



NOTE

AV2-2 only



NOTE

Press the battery cut-off switch if storing for more than two days.

If no battery cut-off switch is fitted to your machine, remove the negative battery cable from the battery if a standstill period of more than two weeks is expected.

Draining diesel

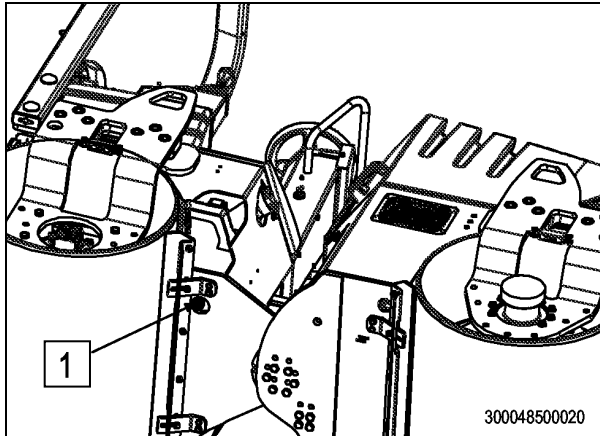

Unscrew the screw **(1)** under the roller using a square socket wrench (13 mm). You can find this wrench on the ratchet of the socket wrench set.

Place a container under the drain tap and let the diesel run out.

11 Hydraulics diagram

AV23 - AV40 hydraulics diagram legend

Element	Description
1	Drive pump
2	Vibration steering pump
3	Feed pump
4	Vibro switch valve
5	Front drive motor
6	Rear drive motor
7	Vibration front
8	Vibration rear
9	Steering unit
10	Hydraulic tank
11	Return filter
12	Oil cooler
13	Steering
15	Electrically switchable flow divider option

Hydraulic diagram AV23K-AV40K

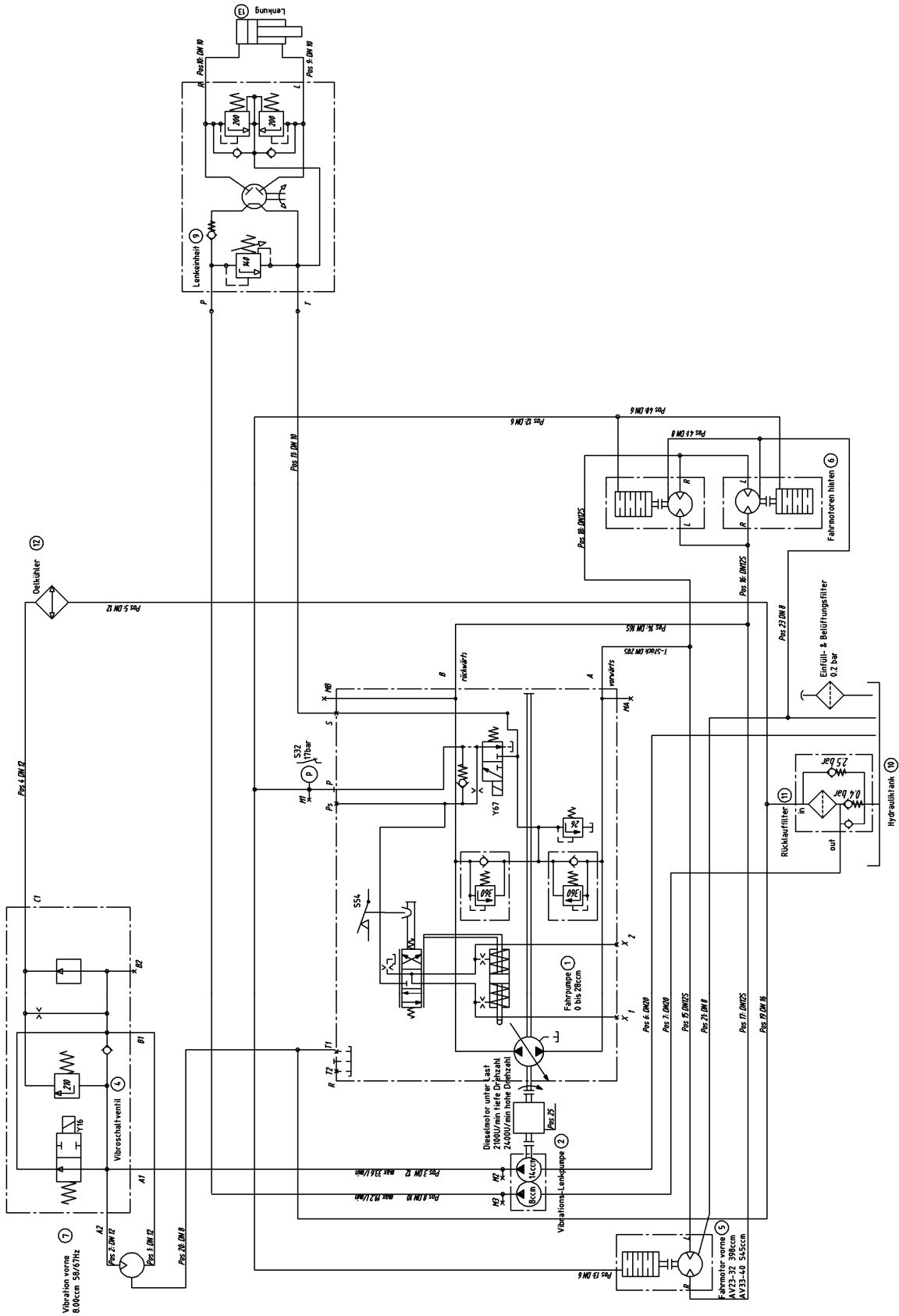

Drawing number: 1-30004751

AV23K - AV40K hydraulics diagram legend

Element	Description
1	Drive pump
2	Vibration steering pump
3	Feed pump
4	Vibro switch valve
5	Front drive motor
6	Rear drive motor
7	Vibration front
9	Steering unit
10	Hydraulic tank
11	Return filter
12	Oil cooler
13	Steering

AV23K - AV40K Edge Cutter hydraulics diagram legend

Element	Description
1	Drive pump
2	Vibration steering pump
3	Feed pump
4	Vibro switch valve
5	Front drive motor
6	Rear drive motor
7	Vibration front
8	Vibration rear
9	Steering unit
10	Hydraulic tank
11	Return filter
12	Oil cooler
13	Steering
15	Flow divider
16	Flow regulator valve
17	Pressure relief valve
18	Control block
19	Edge cutter cylinder

12 Wiring diagram

Wiring diagram (multifunction display)

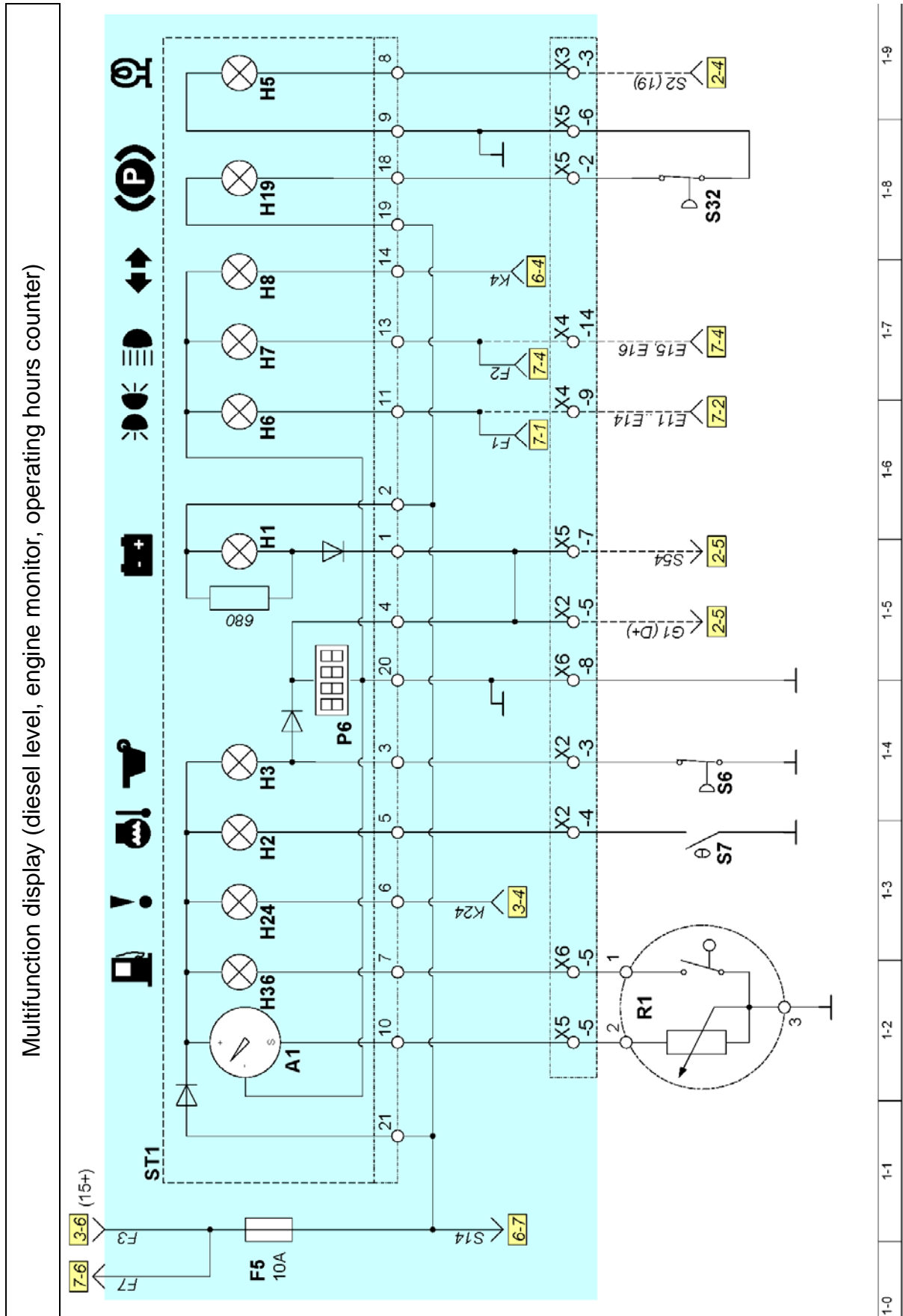

Wiring diagram (engine start/stop)

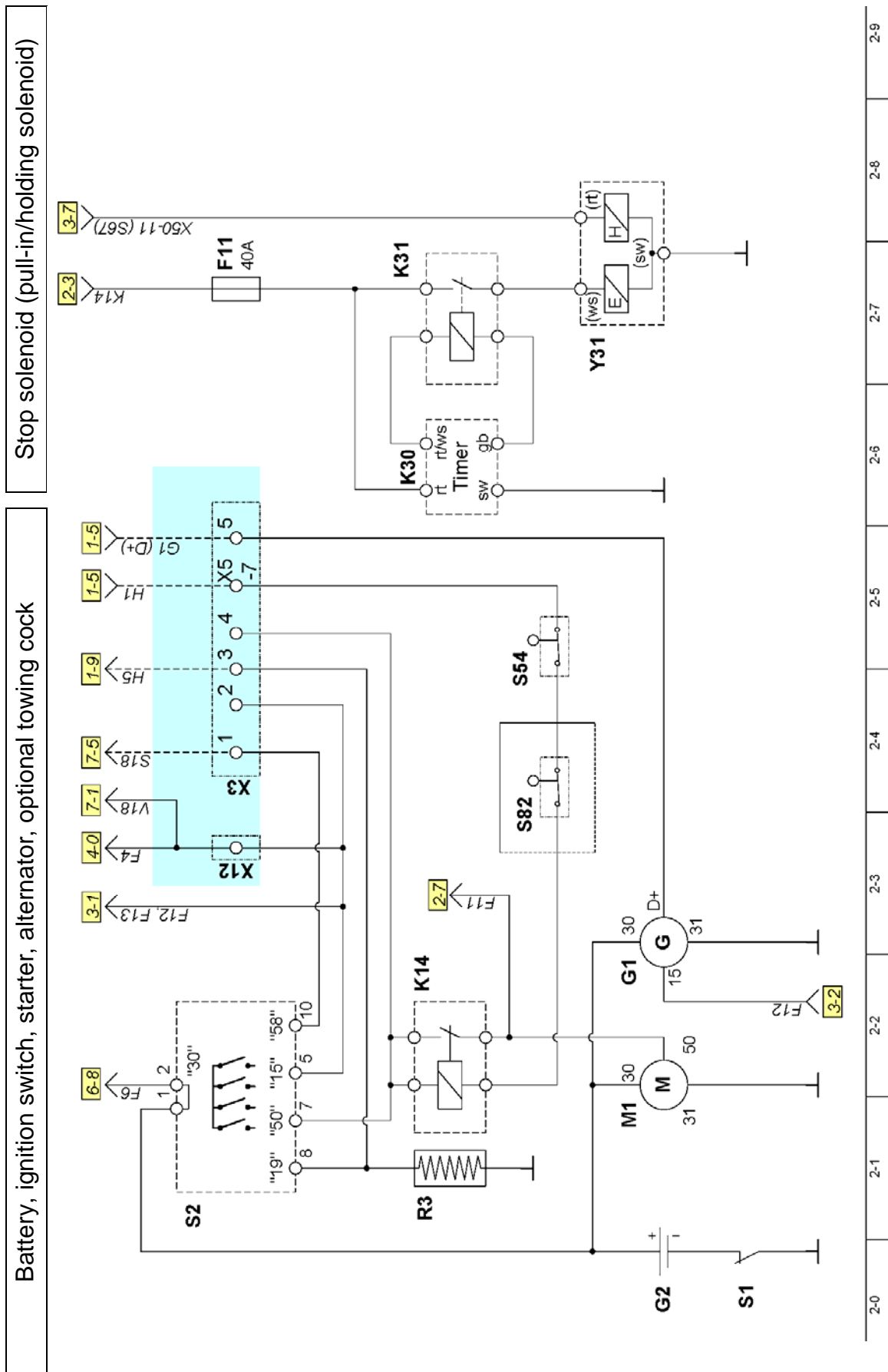

Wiring diagram (emergency stop / oil cooler, diesel pump)

Emergency stop circuit, operating lever zero position, seat contact

Fan for oil cooler / diesel pump / alternator (15)

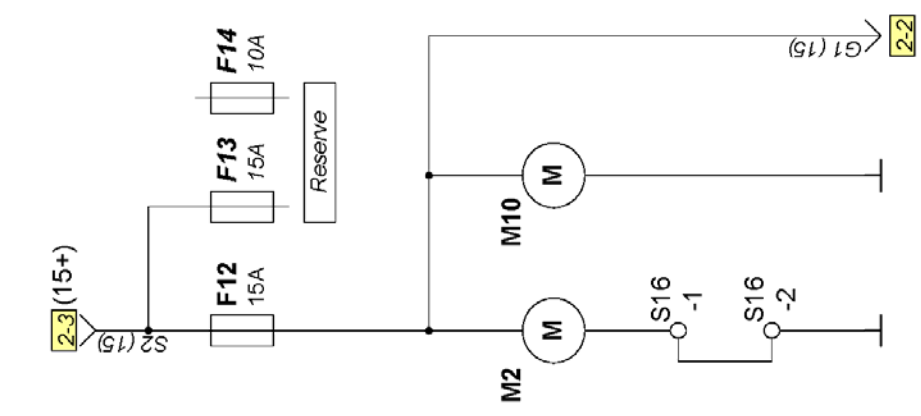
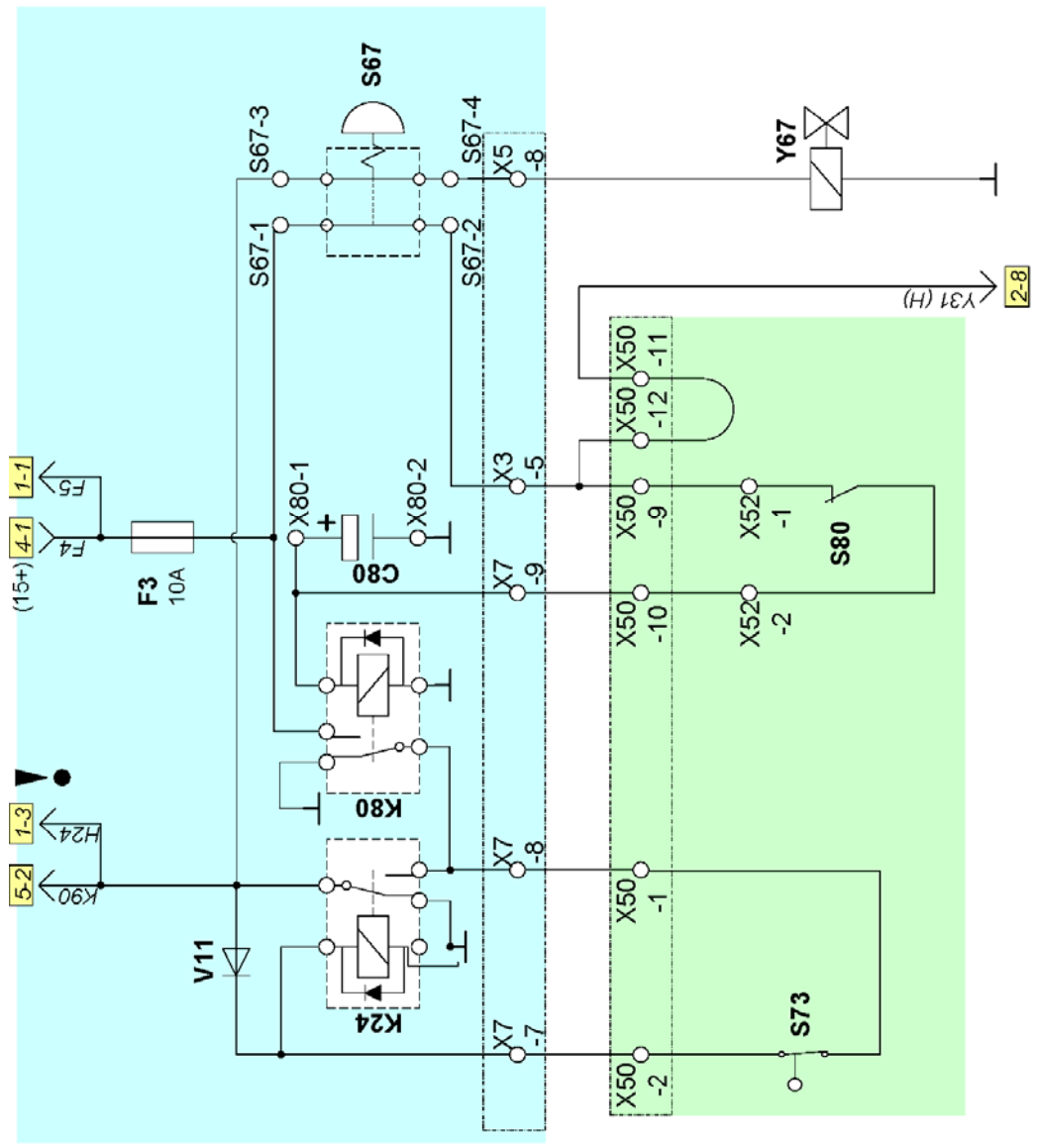

3-0	3-1	3-2	3-3	3-4	3-5	3-6	3-7	3-8	3-9
-----	-----	-----	-----	-----	-----	-----	-----	-----	-----

Wiring diagram (sprinkler)

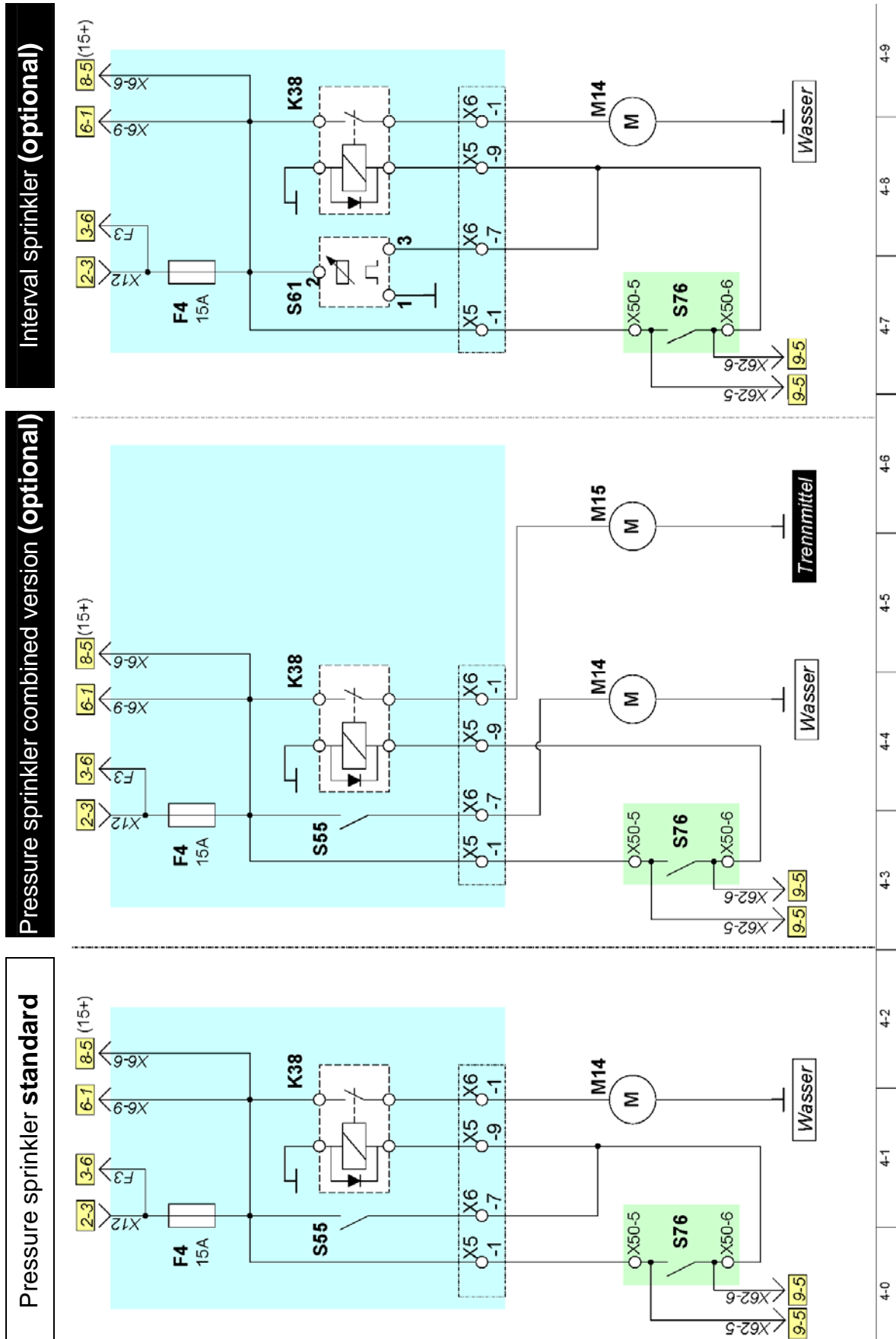

Wiring diagram (lights)

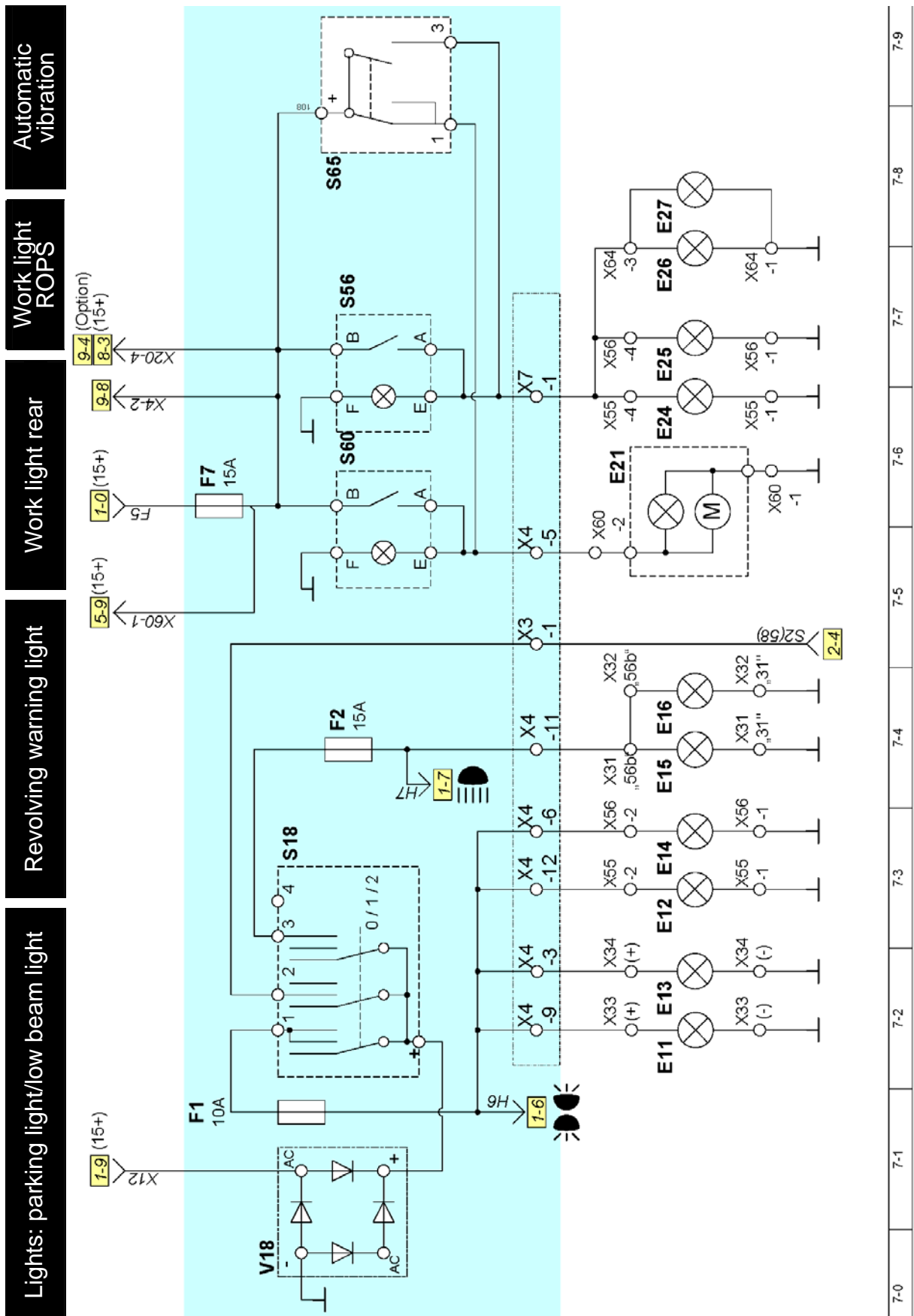

Wiring diagram (options)

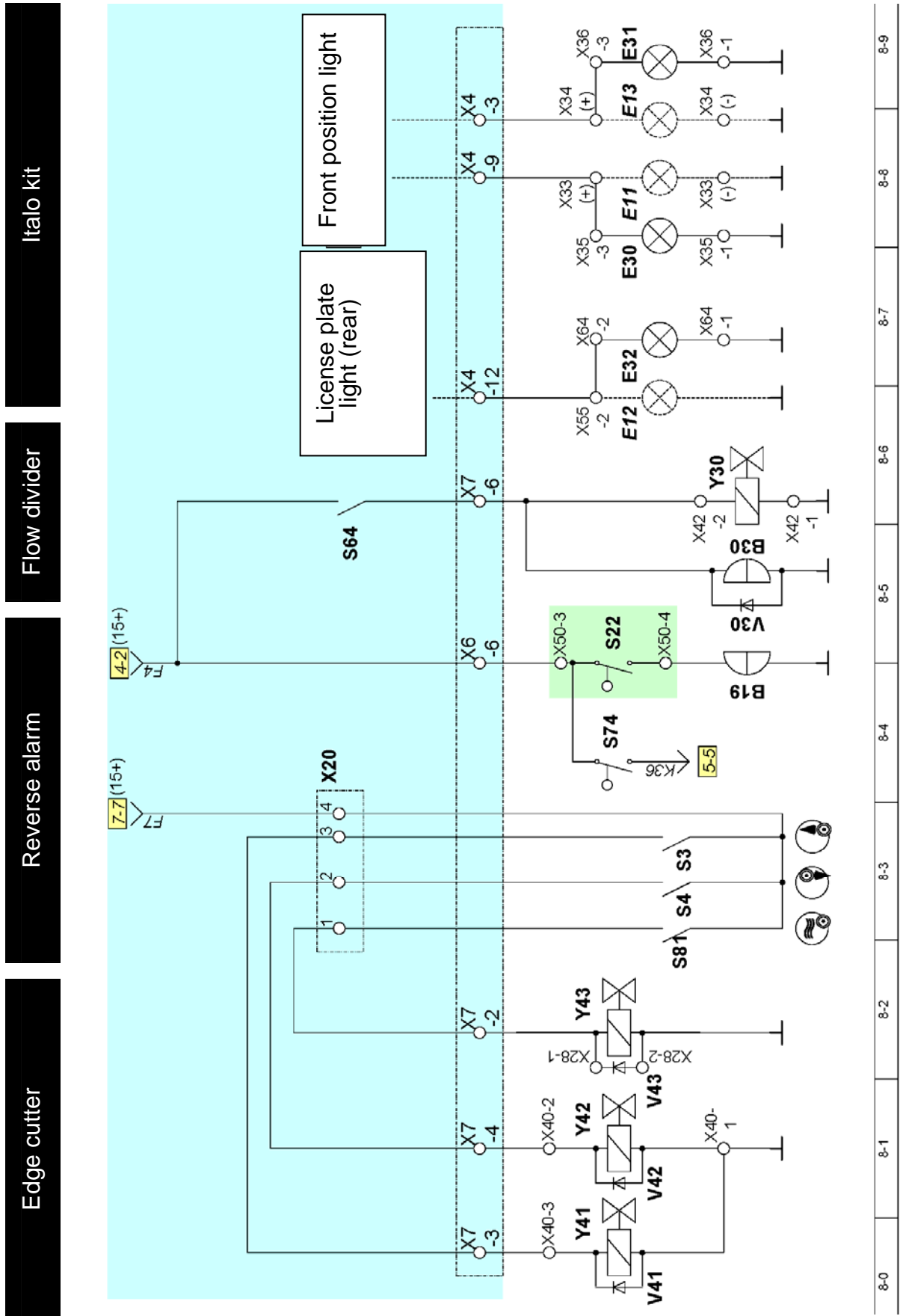

8-0	8-1	8-2	8-3	8-4	8-5	8-6	8-7	8-8	8-9
-----	-----	-----	-----	-----	-----	-----	-----	-----	-----

Wiring diagram (delayed seat switch)

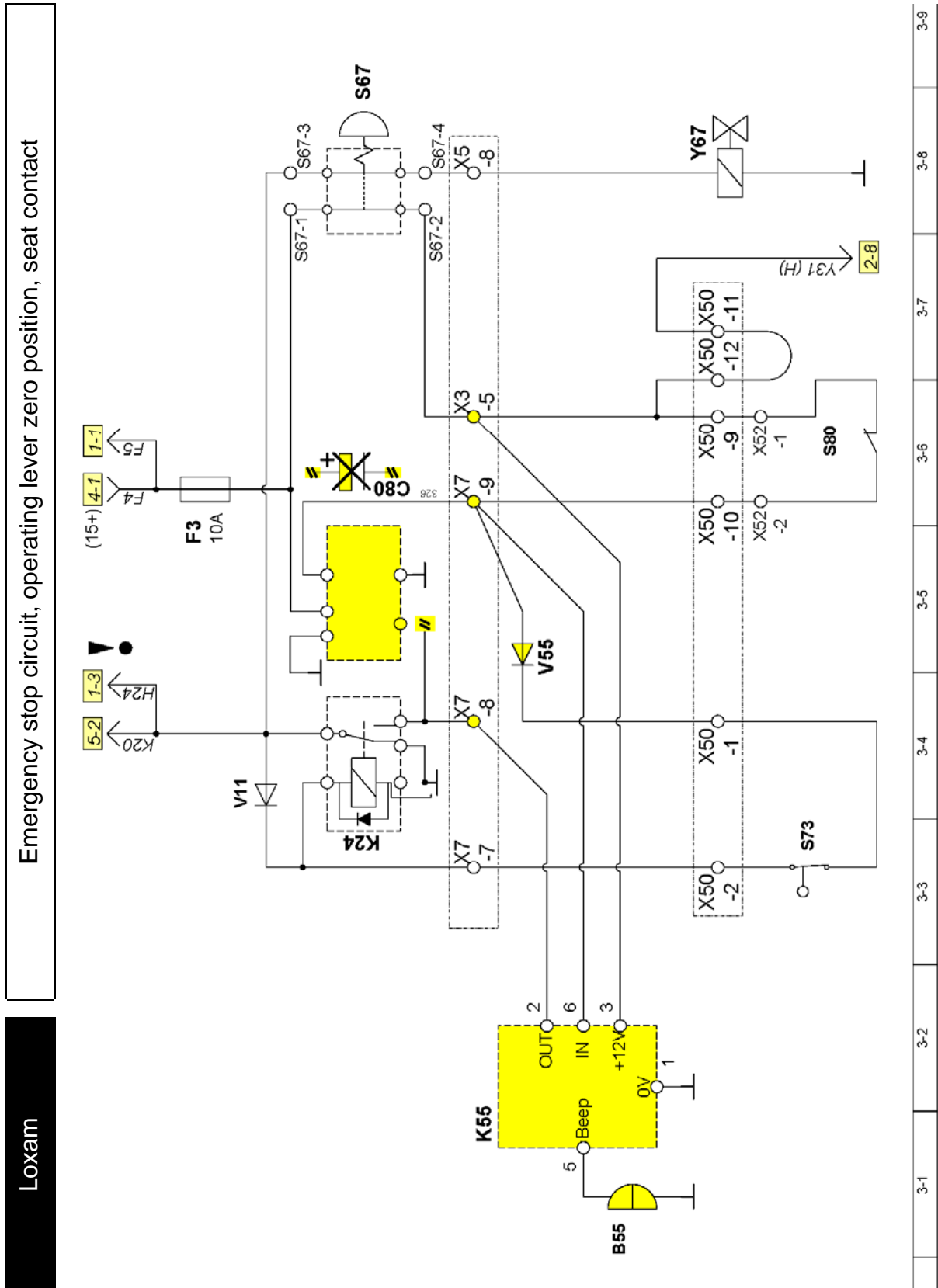

Wiring diagram key

Element	Description
A1	Fuel display
B3	Horn
B4	Buzzer, ROPS2D
B19	Reversing buzzer (*)
B30	Flow divider buzzer (*)
B55	Seat switch seat contact delay buzzer (*)
C80	Capacitor for seat switch
E6	Front left indicator (*)
E7	Rear left indicator (*)
E8	Front right indicator (*)
E9	Rear right indicator (*)
E11	Front left parking light (*)
E12	Rear left parking light (*)
E13	Front right parking light (*)
E14	Rear right parking light (*)
E15	Front left low beam light (*)
E16	Front right low beam light (*)
E21	Revolving warning light (*)
E24	Rear left work light (*)
E25	Rear right work light (*)
E26	Work headlight, left on ROPS (*)
E27	Work headlight, right on ROPS (*)
E30	Front left position light (*)
E31	Front right position light (*)
E32	License plate light, rear (*)
E40	Heating, seat heating
F1	Parking light fuse
F2	Low beam light fuse
F3	Fuse, emergency stop, holding solenoid
F4	Fuse, sprinkler, horn, reverse alarm, flow divider
F5	Fuse, displays, indicators
F6	Fuse, hazard flasher

Wiring diagram key

Element	Description
F7	Fuse, work headlight, revolving warning light, edge cutter
F11	Fuse, pull-in solenoid
F12	Fuse, fan for oil cooler, diesel pump, alternator
F13	Fuse, reserve (15+)
F14	Fuse, reserve
G1	Alternator
G2	Battery
H1	Control lamp, charging control
H2	Control lamp, cooling water temperature
H3	Control lamp, engine oil pressure
H5	Control lamp, pre-heating
H6	Control lamp, parking light
H7	Control lamp, low beam light
H8	Control lamp, indicator
H19	Control lamp, supply pressure (brake pressure)
H24	Control lamp, emergency stop
H36	Control lamp for fuel reserve
H40	Control lamp, ROPS2D (*)
K4	Relay, indicator (*)
K14	Relay, starting interlock
K20	Relay, vibration
K24	Relay, emergency stop
K30	Timer relay
K31	Relay, pull-in solenoid
K36	Relay, automatic vibration
K38	Relay, sprinkler
K55	"Delayed seat switch" timer (*)
K80	Relay, seat contact
K90	Relay, ROPS2D (*)
M1	Starter motor
M2	Engine, fan for oil cooler
M10	Engine diesel pump

Wiring diagram key

Element	Description
M14	Engine, sprinkler pump
M15	Engine, anti-adhesive pump (*)
N1	Tilt sensor, ROPS2D (*)
P6	Operating hours counter
R1	Sensor, fuel level
R3	Heating coil
S1	Battery cut-off switch (*)
S2	Ignition switch
S3	Switch, edge cutter up (*)
S4	Switch, edge cutter down (*)
S6	Sensor (switch), engine oil pressure
S7	Sensor (switch), cooling water temperature
S13	Switch, horn
S14	Switch, hazard flasher (*)
S16	Sensor (switch), oil temperature
S18	Switch, light (parking light / low beam light) (*)
S22	Switch, operating lever reverse position
S32	Sensor (switch), supply pressure (brake pressure)
S54	Switch, drive pump zero position
S55	Switch, continuous sprinkling
S56	Switch, work light (*)
S57	Switch, vibration
S58	Switch, indicator left / right (*)
S59	Switch, vibration selector (*)
S60	Switch, beacon light (*)
S61	Switch, interval sprinkler control (*)
S64	Switch, flow divider (*)
S65	Switch, Pos. 1: Revolving warning light/ Pos. 2: Work light & revolving warning light (*)
S67	Switch, emergency stop
S73	Switch, operating lever neutral position
S76	Switch, sprinkler (button) / anti-adhesive (*)

Wiring diagram key

Element	Description
S80	Switch, seat contact
S81	Switch, edge cutter sprinkler (*)
S82	Switch, towing eye (*)
S83	Switch, edge cutter down / up (*)
S85	Switch, manual / automatic vibration (*)
ST1	Multifunction display unit
V11	Diode, emergency stop (self-latching, emergency stop relay)
V18	Diodes, lock diode, parking position/free-running diode, supply (15+)
V20	Diode, free-running diode, vibration valve
V30	Diode, free-running diode to flow divider (*)
V41	Diode, free-running diode to edge cutter valve (*)
V42	Diode, free-running diode to edge cutter valve (*)
V43	Diode, free-running diode to edge cutter valve (*)
V55	Diode, lock diode "delayed seat switch" (*)
X2...X7	Connector on relay panel
X12	Connector, relay panel supply connection
X20	Connector, edge cutter switch connection
X28	Connector, edge cutter diode connection
X40	Connector, edge cutter valve connection
X42	Connector, flow divider valve connection (on AV2 only)
X50	Connector, operating lever console connection
X52	Connector, seat contact connection
X60	Plug, tilt sensor connection (*)
X62	Plug, operating lever control (*)
X70	Socket, seat heating (*)
Y14	Valve, sprinkler (**)
Y15	Valve, anti-adhesive (**)
Y16	Valve, front vibration
Y17	Valve, rear vibration (*)
Y30	Valve, flow divider (*) (only for AV2-2)
Y31	Stop solenoid; (stop solenoid; pull-in and holding solenoid)
Y41	Valve, edge cutter up (*)

Wiring diagram key

Element	Description
Y42	Valve, edge cutter down (*)
Y43	Valve, edge cutter sprinkler (*)
Y67	Valve, emergency stop (service brake)

(*) Optional

(**) Not available

13 Specifications

Dimensions

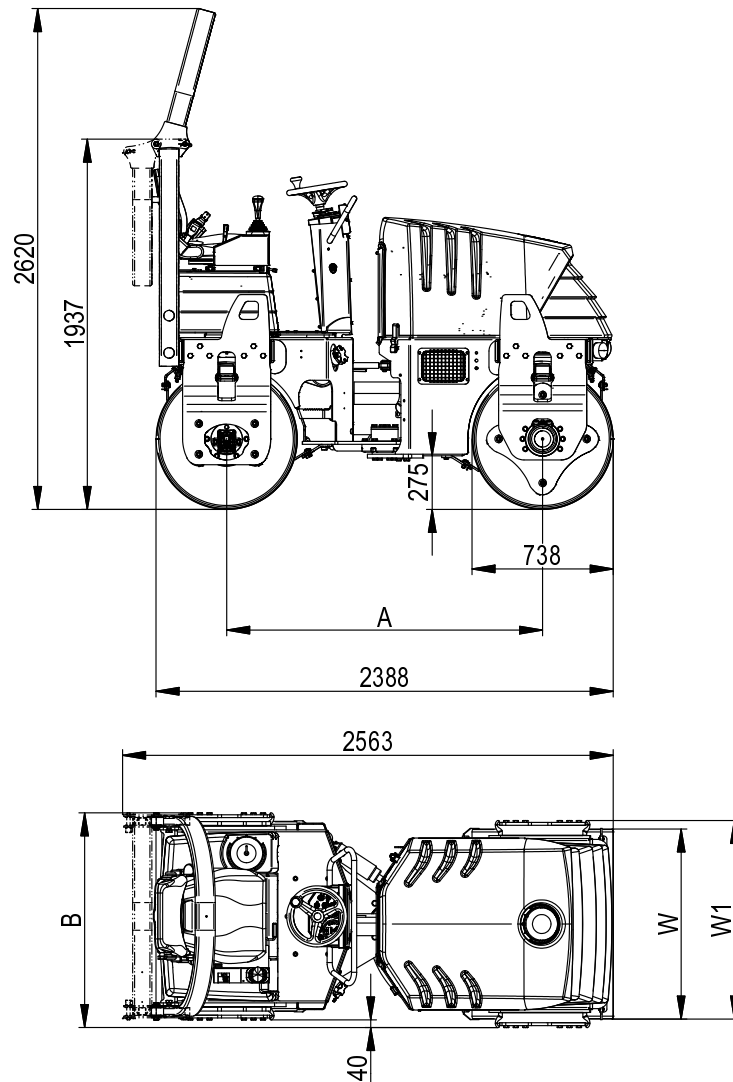

30004 8495003

	AV23-2	AV26-2	AV32-2	AV33-2	AV40-2
A	1650	1650	1650	1650	1650
B	1121	1326	1310	1412	1412
W	995	1200	1200	1300	1300
W1	1038	1243	1235	1335	1335

	AV23-2K	AV26-2K	AV32-2K	AV40-2K
A	1701	1701	1701	1701
B	1065	1288	1288	1370
W	995	1200	1200	1300
W1	1038	1243	1235	1335

Specifications AV2-2

	AV23-2	AV26-2	AV32-2	AV33-2	AV40-2
Service weight according to CECE (kg)	2410	2660	3160	3450	3800
Static linear load (kg/cm)	12.1	11.1	13.2	13.3	14.6
Wheel load (kg)	-	-	-	-	-
Outside turning radius/inside (mm)	3350 / 2350	3450 / 2250	3450 / 2250	3500 / 2200	3500 / 2200
Amplitude (mm)	0.42	0.45	0.41	0.33	0.33
Compaction force per roller drum (kN)	34 / 41	38 / 46	38 / 46	36 / 48	36 / 48
Max. gradient in % with/without vibration (N/cm)	30 / 40	30 / 40	30 / 40	30 / 40	25 / 35
Drive	YANMAR 3TNV88 / Euromot 3A - EPA Inter 4				
Output to DIN 6270 B	1.) 19.8kW / 27 PS 2.) 23.2 kW / 31.5 PS				
Operating speed	1.) 2,100 1/min 2.) 2,400 1/min				
Driving speed	0-10 km/h				
Steering angle/pivoting	± 32° / ± 8°				
Vibration frequency	1.) 58 Hz 2.) 66 Hz				

Fill levels:	
Water tank	80l + 120l
Hydraulic oil tank	25l
Fuel oil tank	43l

Specifications AV2-2K

	AV23-2K	AV26-2K	AV32-2K	AV40-2K
Service weight according to CECE (kg)	2280	2400	3110	3540
Static linear load (kg/cm)	12.1	11.1	13.2	14.6
Wheel load (kg)	278	278	383	408
Outside turning radius/inside (mm)	3350 / 2350	3450 / 2250	3450 / 2250	3500 / 2200
Amplitude (mm)	0.42	0.45	0.41	0.33
Compaction force per roller drum (kN)	34 / 41	38 / 46	38 / 46	36 / 48
Gradient in % with/without vibration (N/cm)	30 / 40	30 / 40	30 / 40	25 / 35
Drive	YANMAR 3TNV88 / Euromot 3A - EPA Inter 4			
Output to DIN 6270 B	1.) 19.8kW / 27 PS 2.) 23.2 kW / 31.5 PS			
Operating speed	1.) 2,100 1/min 2.) 2,400 1/min			
Driving speed	0-10 km/h			
Steering angle/pivoting	± 32° / ± 8°			
Vibration frequency	1.) 58 Hz 2.) 66 Hz			

Fill levels:	
Water tank	80 l + 120 l
Hydraulic oil tank	25 l
Anti-adhesive tank	14 l
Fuel oil tank	43 l

Specifications AV2-2 sidefree

	AV23-2	AV23-2K	AV26-2	AV26-2K
Service weight according to CECE (kg)	2650	2450	2850	2520
Static linear load (kg/cm)	12.7	13.4	11.4	11.7
Wheel load (kg)	-	279	-	285
Outside turning radius/inside (mm)	3350 / 2350	3350 / 2350	3450 / 2250	3450 / 2250
Amplitude (mm)	0.37	0.37	0.41	0.41
Compaction force per roller drum (kN)	34 / 41	34 / 41	38 / 46	38 / 46
Max. gradient in % with/without vibration (N/cm)	30 / 40	30 / 40	30 / 40	30 / 40
Drive	YANMAR 3TNV88 / Euromot 3A - EPA Inter 4			
Output to DIN 6270 B	1.) 19.8kW / 27 PS 2.) 23.2 kW / 31.5 PS			
Operating speed	1.) 2,100 1/min 2.) 2,400 1/min			
Driving speed	0-10 km/h			
Steering angle/pivoting	± 32° / ± 8°			
Vibration frequency	1.) 58 Hz 2.) 66 Hz			

Fill levels:	
Water tank	80 l + 120 l
Hydraulic oil tank	25 l
Anti-adhesive tank	14 l
Fuel oil tank	43 l

